



WE LIFT YOUR PROFIT

ED. 63

## CATALOGO GENERALE

GENERAL CATALOGUE

CATALOGUE GÉNÉRAL

GESAMTKATALOG

Made in Italy 





ED. 63

# CATALOGO GENERALE

GENERAL CATALOGUE • CATALOGUE GÉNÉRAL • GESAMTKATALOG



Grazie ad una costante e continua crescita ci presentiamo oggi alla nostra clientela come azienda leader, nel settore dell'auto attrezzatura e non solo, a livello internazionale, con strutture produttive su una superficie coperta di 60.000 mq ed un'area globale di 100.000 mq.



Al fine di poter realizzare prodotti di qualità assolutamente controllata e garantita, abbiamo deciso di seguire un percorso produttivo a 360° partendo cioè dalla materia prima per giungere al prodotto finito sia per quanto riguarda tutti i componenti meccanici, che quelli idraulici e questo vale per tutta la gamma dei nostri prodotti, rappresentata da oltre 600 articoli omologati e certificati CE. Siamo impegnati in una costante attività di ricerca e sviluppo per offrire prodotti tecnologicamente avanzati, affidabili e sicuri sotto ogni aspetto, tutti ideati, progettati e fabbricati internamente. I nostri apparecchi sono conformi alle direttive europee quali la Direttiva Macchine 2006/42/CE, la Direttiva 2014/35/UE (bassa tensione), la Direttiva 2014/30/UE (compatibilità elettromagnetica). Oltre a ciò ogni nostro singolo articolo è sviluppato e realizzato applicando, su base volontaria, specifiche norme internazionali di prodotto. In particolare tutti i ponti sollevatori da noi commercializzati risultano conformi ed omologati rispetto alla norma europea EN 1493 - Vehicle lifts. Per garantire tutto ciò i nostri tecnici interni mantengono contatti continuativi con enti normativi internazionali, organismi di certificazione (Bureau Veritas, Tuv, Icepi, Apave Normande) e vigilanza e con primarie società di consulenza. Abbiamo inoltre inserito, nell'ambiziosità dei nostri progetti, una assoluta volontà di lasciare un'impronta che conta del "Made in Italy" di qualità garantita. La nostra radicata e capillare presenza sul mercato nazionale e quella in oltre 100 stati esteri, crediamo possano essere la nostra migliore credenziale. Una strutturata e professionale rete di assistenza ed un'importante copertura assicurativa "RESPONSABILITA' PRODOTTO" valida per 10 anni su tutti gli articoli di nostra produzione, sono i complementi del nostro concetto di qualità.



Thanks to a constant and continue growth, today we introduce ourselves to our customers as a leader company in garage equipment and not only, on an international level, with productive structures on a covered area of 60.000 m<sup>2</sup> and a global area of 100.000 m<sup>2</sup>.



To realize products of absolutely tested and guaranteed quality, we decided to follow a productive process at 360°, starting from the raw material till the completed product, both for mechanical parts and hydraulic parts; this is referred to all our products, composed by more than 600 CE approved and certified articles. We are engaged in a continuous research and development activity to offer technologically advanced, reliable and safe products each conceived, designed and manufactured inside our company. Our machines comply with the European directives like the Machinery directive 2006/42/CE, the directive 2014/35/UE (low voltage) as well as the Directive 2014/30/UE (electromagnetic compatibility). In addition to this, every single article of our product range has been developed and manufactured following voluntarily the specific international norms concerning this product. In particular, all of our commercialized lifts are homologated and comply with the European norm EN 1493 - Vehicle lifts. In order to comply with these norms, our technicians are continuously in contact with some international regulatory authorities, with certification authorities like Bureau Veritas, Tuv, Icepi, Apave Normande as well as with top consulting companies. We also put in our ambitious projects an absolute will to keep a relevant sign of the "Made in Italy" of guaranteed quality. Our deep and extended presence on a domestic market and in more than 100 foreign countries, we believe, can be our best reference.

A well organized and professional network of assistance and an important insurance cover "PRODUCT RESPONSIBILITY" valid for 10 years on all the articles of our production are the complements to our concept of quality.



Nous sommes une société leader au niveau international dans le secteur de l'équipement industriel et de garage, dotée d'unités de production couvertes de 60.000 m<sup>2</sup> pour une superficie globale de 100.000 m<sup>2</sup>.



Pour atteindre notre objectif de réaliser des produits de qualité contrôlée et garantie, nous avons opté pour un parcours à 360°, en partant de la matière première pour aboutir au produit fini. Nous appliquons ce principe à tous nos composants mécaniques et hydrauliques et à toute notre gamme de produits, qui s'élève à 600 articles aux normes CE. La branche recherche et développement de OMCN est en activité constante pour offrir toujours des produits à la pointe de la technologie, fiables et sûrs sous tous points de vue, tous conçus, réalisés et fabriqués en interne. Nos machines sont conformes aux directives européennes telles que la Directive Machines 2006/42/CE, la Directive 2014/35/UE (basse tension), la Directive 2014/30/UE (compatibilité électromagnétique). De plus, nous choisissons d'appliquer volontairement certaines normes internationales spécifiques de produit à chacun de nos articles. En particulier, tous les ponts élévateurs que nous commercialisons sont conformes et homologués selon la norme européenne EN 1493 – Vehicle lifts. Pour garantir tout cela à nos clients, nos techniciens en interne, sont toujours en contact avec les instituts d'homologation internationaux, organismes de certification (Bureau Veritas, Tuv, Icepi, Apave Normande) et de vigilance, ainsi qu'avec des sociétés de conseils de tout premier plan. Ambitieux dans nos projets, nous souhaitons laisser une empreinte de qualité garantie "Made in Italy". Notre importante représentation sur le marché national et dans plus de 100 pays dans le monde entier est notre meilleure carte de visite.

Une structure solide, un service après-vente d'un grand professionnalisme et une importante couverture "RESPONSABILITE PRODUIT" valable 10 ans sur tous les articles de notre gamme sont les compléments de notre idée de qualité.



Dank eines beständigen und anhaltenden Wachstums zählt OMCN mit einer Produktionsfläche von 60.000 m<sup>2</sup>, weltweit insgesamt 100.000 m<sup>2</sup> heute zu den führenden Herstellern von Kfz Werkstattausrüstungen und nicht nur in der Welt.



Um Produkte in erstklassig garantierter Qualität herstellen zu können, unterliegen alle OMCN-Erzeugnisse vom Wareneingang des Rohmaterials bis hin zum fertigen (mechanischen oder hydraulischen) Produkt ständig umfangreichen Qualitätskontrollen. Dies gilt für alle OMCN-Produkte und wird durch mehr als 600 "Ce"-Zertifizierungen belegt. Wir sind einer ständigen Forschungs- und Entwicklungstätigkeit eingesetzt, um technologisch fortschrittliche, sichere und zuverlässige Produkte zu bieten, die innerhalb des Unternehmens ausgedacht, entworfen und hergestellt werden.

Unsere Geräte sind den europäischen Richtlinien, wie die Maschinen Richtlinie 2006/42/CE, die Richtlinie 2014/35/UE (Niederspannungsrichtlinie) sowie die Richtlinie 2014/30/UE (Elektromagnetische Verträglichkeit) entsprechend. Darüber hinaus wird jeder einzelne unserer Artikel entwickelt und umgesetzt, auf freiwilliger Basis, um allen internationalen Richtlinien zu entsprechen. Insbesondere, sind alle Hebebühnen, die wir vermarkten, der europäischen Richtlinie EN 1493 - Vehicle lifts entsprechend und zugelassen. Um dies sicherzustellen, halten alle unsere Techniker laufenden Kontakte mit internationalen Regelungsbehörden, mit Produktzertifizierung- und Aufsichtsstellen (wie Bureau Veritas, Tüv, Icepi, Apave Normande) sowie mit wichtigen Beratungsgesellschaften.

Ein gut und professionell organisiertes Händlernetz und eine wichtige, für einen Zeitraum von 10 Jahren gültige "PRODUKTHAFTUNGS-GARANTIE" für alle OMCN-Produkte, sind die Vervollständigung unseres Qualitäts-Begriffes.

P. 009



**PONTI SOLLEVATORI ELETTROMECCANICI A 2 COLONNE**  
ELECTROMECHANICAL 2-POST LIFTS  
PONTIS ELEVATEURS A 2 COLONNES ELECTROMECHANIQUES  
ELEKTROMECHANISCHE 2-SÄULEN HEBEBÜHNEN

P. 073



**PONTI SOLLEVATORI ELETTROIDRAULICI A FORBICE**  
ELECTROHYDRAULIC SCISSOR LIFTS  
PONTIS ELEVATEURS A CISEAUX ELECTROHYDRAULIQUES  
ELEKTROHYDRAULISCHE SCHEREN-HEBEBÜHNEN

P. 029



**PONTI SOLLEVATORI ELETTROIDRAULICI A 2 COLONNE**  
ELECTROHYDRAULIC 2-POST LIFTS  
PONTIS ELEVATEURS A 2 COLONNES ELECTROHYDRAULIQUES  
ELEKTROHYDRAULISCHE 2-SÄULEN HEBEBÜHNEN

P. 087



**PONTI SOLLEVATORI ELETTROIDRAULICI SERIE X-LINE**  
ELECTROHYDRAULIC X-LINE LIFTS  
PONTIS ELEVATEURS ELECTROHYDRAULIQUES X-LINE  
ELEKTROHYDRAULISCHE HEBEBÜHNEN X-LINE

P. 043



**PONTI SOLLEVATORI ELETTROIDRAULICI A CILINDRI INTERRATI**  
HYDRAULIC 2-RAM INGROUND LIFTS  
PONTIS ELEVATEURS ENCASTRES A VERINS HYDRAULIQUES  
HYDRAULISCHE 2-ZYLINDER UNTERFLUR STEMPEL-BÜHNEN

P. 095



**PONTI SOLLEVATORI ELETTROIDRAULICI A 4 COLONNE**  
ELECTROHYDRAULIC 4-POST LIFTS  
PONTIS ELEVATEURS A 4 COLONNES ELECTROHYDRAULIQUES  
ELEKTROHYDRAULISCHE 4-SÄULEN HEBEBÜHNEN

P. 049



**PONTI SOLLEVATORI ELETTROIDRAULICI A DOPPIA FORBICE**  
ELECTROHYDRAULIC TWIN-SCISSOR LIFTS  
PONTIS ELEVATEURS A DOUBLE CISEAUX ELECTROHYDRAULIQUES  
ELEKTROHYDRAULISCHE DOPPEL-SCHEREN-HEBEBÜHNEN

P. 107



**PONTI SOLLEVATORI ELETTROMECCANICI A 4 COLONNE PER VEICOLI INDUSTRIALI**  
ELECTROMECHANICAL 4-POST LIFTS FOR HEAVY VEHICLES  
PONTIS ELEVATEURS ELECTROMECHANIQUES 4 COLONNES POUR POIDS LOURDS  
ELEKTROMECHANISCHE 4-SÄULEN HEBEBÜHNEN FÜR SCHWERE FAHRZEUGE

P. 067



**SOLLEVATORI PER CARROZZERIA**  
LIFTS FOR CAR-BODY SHOP  
ELEVATEURS POUR CARROSSERIE  
FAHRBARE KURZHUBBÜHNEN FÜR KAROSSERIE

P. 113



**PONTI SOLLEVATORI ELETTROIDRAULICI A FORBICE PER VEICOLI INDUSTRIALI**  
ELECTROHYDRAULIC SCISSOR LIFTS FOR HEAVY VEHICLES  
PONTIS ELEVATEURS ELECTROHYDRAULIQUES A CISEAUX POUR POIDS LOURDS  
ELEKTROHYDRAULISCHE SCHEREN-HEBEBÜHNE FÜR SCHWERE FAHRZEUGE

P. 123



**SOLLEVATORI A COLONNE MOBILI**  
MOBILE COLUMN LIFTS  
ELEVATEURS A COLONNES MOBILES  
FAHRBARER LKW-RADGREIFER

P. 167



**ATTREZZATURE PER VEICOLI INDUSTRIALI**  
HEAVY VEHICLES EQUIPMENT  
EQUIPEMENTS POUR POIDS LOURDS  
GERÄTE FÜR LKW-REPARATUREN

P. 133



**SOLLEVATORI PER MOTO**  
MOTOR-BIKE LIFTS  
ELEVATEURS POUR MOTOS  
MOTORRAD-HEBEBÜHNEN

P. 179



**SOLLEVATORI IDRAULICI A BOTTIGLIA E BINDE IDRAULICHE**  
HYDRAULIC BOTTLE JACKS AND HYDRAULIC TRACK JACKS  
CRICS A BOUTEILLE ET CRICS LEVE-MACHINE HYDRAULIQUES  
HYDRAULISCHE WAGENHEBER UND MASCHINENHEBER

P. 147



**PROVAGIOCHI ELETTROIDRAULICI**  
ELECTROHYDRAULIC PLAY DETECTORS  
PLAQUES A JEUX ELECTROHYDRAULIQUES  
ELEKTROHYDRAULISCHE GELENKSPIEL-TESTVORRICHTUNG

P. 185



**SOLLEVATORI IDRAULICI A CARRELLO**  
HYDRAULIC TROLLEY JACKS  
CRICS ROULEURS HYDRAULIQUES  
HYDRAULISCHE RANGIERHEBER

P. 151



**TRAVERSE DI SOLLEVAMENTO**  
JACKING BEAMS  
TRAVERSES DE LEVAGE  
SCHERENHEBER

P. 211



**COLONNETTE DI SOSTEGNO E CAVALLETTI MOTORE**  
AXLE STANDS AND ENGINE STANDS  
CHANDELLES ET SUPPORT MOTEURS  
UNTERSTELLBÖCKE UND REPARATURSTÄNDER

P. 159



**SOLLEVATORI IDRAULICI DA FOSSA E SOTTOPONTE**  
HYDRAULIC TRANSMISSION JACKS  
VERINS DE FOSSE HYDRAULIQUES  
HYDRAULISCHE GETRIEBEHEBER

P. 221



**CARELLI E BANCHI DA LAVORO**  
TROLLEYS AND WORKBENCHES  
CHARIOTS ET ETABLIS DE TRAVAIL  
WAGEN UND WERKBÄNKE



P. 231



**ATTREZZI SPECIALI PER LA CARROZZERIA**  
SPECIAL EQUIPMENT FOR CAR-BODY SHOP  
OUTILS DE CARROSSIER  
SPEZIALGERÄTE FÜR KAROSSERIEARBEITEN

P. 277



**ELEVATORI E TRANSPALLET**  
ELEVATORS AND TRANSPALLETS  
ELEVATEURS ET TRANSPALLETES  
HUBWAGEN UND PALETTENHUBWAGEN

P. 241



**UTENSILI PROFESSIONALI**  
PROFESSIONAL TOOLS  
OUTILS PROFESSIONNELS  
KAROSSERIE-RICHTWERKZEUG

P. 283



**CURVATUBI**  
PIPE BENDING MACHINES  
CINTREUSES  
ROHRBIEGEMASCHINEN

P. 249



**MARTINETTI IDRAULICI PER CARROZZERIA**  
HYDRAULIC JACKS FOR CAR-BODY SHOP  
VERINS HYDRAULIQUES POUR CARROSSERIE  
HYDRAULISCHE RICHTSÄTZE FÜR DEN KAROSSERIEBAU

P. 287



**POMPE E CILINDRI IDRAULICI PER APPLICAZIONI INDUSTRIALI**  
HYDRAULIC PUMPS AND CYLINDERS FOR INDUSTRIAL SOLUTIONS  
POMPES ET VERINS HYDRAULIQUES : SOLUTIONS POUR L'INDUSTRIE  
PUMPEN UND ZYLINDER FÜR INDUSTRIELLE ANWENDUNGEN

P. 259



**RADDRIZZATORI PER CARROZZERIA**  
STRAIGHTENERS FOR CAR-BODY SHOP  
EQUERRES DE REDRESSAGE POUR CARROSSERIE  
KAROSSERIE-RICHTGERÄTE

P. 299



**PRESSE IDRAULICHE**  
HYDRAULIC PRESSES  
PRESSES HYDRAULIQUES  
HYDRAULISCHE PRESSEN

P. 263



**GRU IDRAULICHE A CARRELLO**  
TROLLEY HYDRAULIC CRANES  
GRUES HYDRAULIQUES A CHARIOT  
FAHRBARE HYDRAULIKKRÄNE

P. 333



**ATTREZZI ECOLOGICI**  
ENVIRONMENTAL EQUIPMENT  
OUTILS ECOLOGIQUES  
ENTSORGUNGSGERÄTE

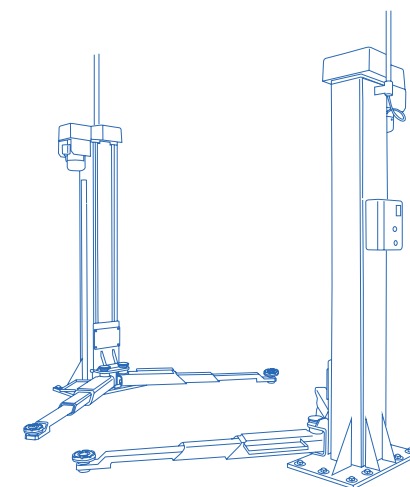

## **PONTI SOLLEVATORI ELETTROMECCANICI A 2 COLONNE**

ELECTROMECHANICAL 2-POST LIFTS  
PONTIS ELEVATEURS A 2 COLONNES ELECTROMECHANIQUES  
ELEKTROMECHANISCHE 2-SÄULEN HEBEBÜHNEN

Made in Italy 



## PONTI SOLLEVATORI ELETTROMECCANICI A 2 COLONNE

### ELECTROMECHANICAL 2-POST LIFTS

#### TRACCIATO TECNICO COSTRUTTIVO

- Funzionamento elettromeccanico.
- Sollevamento a mezzo viti trapezoidali rullate, in acciaio ad alta resistenza, a passo fine per rendere autofrenanti i carrelli.
- Carrelli a scorrimento interno, completamente protetti.
- Chiocciole portanti in materiale speciale, onde ridurre al minimo la lubrificazione.
- Chiocciole di sicurezza autoprotette.
- Quattro rulli di scorrimento per ogni singolo carrello più quattro pattini registrabili garantiscono una perfetta aderenza e scorrevolezza.
- **Trasmissione di moto tra le viti a mezzo catena con protezione elettrica antiallungamento, per garantire silenziosità operativa e maggior elasticità.**
- Motore elettrico sovradimensionato con protezione termica.
- Impianto elettrico a circuito chiuso, con comandi e fine corsa a bassa tensione, funzionamento "uomo presente".
- Verniciatura a polvere epossidica.
- Struttura completamente premontata.
- Pompetta di ingrassaggio in dotazione.
- Tasselli di ancoraggio al suolo in dotazione.

#### TECHNICAL AND STRUCTURAL LAY-OUT

- Electromechanical operating.
- Lifting through trapezoidal turning screws, made of high resistance steel with fine pitch so that trolleys may become self-braking.
- Completely protected internal sliding trolleys.
- Load-bearing nuts from a special material, to minimise lubrication.
- Self-protected safety nuts.
- Monocoque body column structure.
- Four sliding rollers for each trolley, plus four adjustable guide-shoes guarantee a perfect adhesion and flowability.
- **Movement transmission between screws through a chain with electric antislowing protection, in order to guarantee an operating silentness and a higher elasticity.**
- Over-sized electric motor with thermic overload protection.
- Closed-course electrical system, with low-voltage drives and endstrokes, "man standing-by" operating.
- Epoxy powder painting.
- Completely pre-assembled frame.
- Equipped with greasing pump.
- Equipped with anchor small blocks.

# PONTS ELEVATEURS A 2 COLONNES ELECTROMECHANISCHES

## ELEKTROMECHANISCHE 2-SÄULEN HEBEBÜHNEN

### RELEVÉ TECHNIQUE

- Fonctionnement électromécanique.
- Levage par vis trapézoïdales comprimées, en acier haute résistance. Pas de vis fin pour des chariots auto-freinants.
- Chariots internes coulissants entièrement protégés.
- Ecrous portants en matériel spécial, qui réduit au minimum le graissage.
- Ecrous de sécurité autoprotégés.
- Structure colonne en monocoque.
- Quatre roulements coulissants permettent la course de chaque chariot et quatre patins réglables en garantissent une parfaite adhésion et la mobilité.
- **Transmission par chaîne dotée de protection électrique anti-relâchement pour un entraînement souple et silencieux.**
- Moteur électrique surdimensionné avec protection thermique.
- Installation électrique à circuit fermé, commandes et fins de courses basse tension, commandes de type "homme mort".
- Peinture époxy.
- Structure entièrement assemblée en usine.
- Poire de graissage fournie.
- Chevilles d'ancrage au sol fournies.

### TECHNISCHE UND KONSTRUKTIVE ANGABEN

- Elektromechanischer Betrieb.
- Hub erfolgt mittels Trapezgewinde-Spindeln aus Spezialstahl; Abbremsen der Hubschlitten durch selbsthemmende Spindelgewinde.
- Völlig geschützte innenliegende Führungen.
- Tragmuttern aus speziellen Material, um die Schmierung auf ein Minimum zu reduzieren.
- Selbstsichernde Folgemutter.
- Äußerst stabile Konstruktion.
- 4 kugelgelagerte Rollen an jedem Hubschlitten in Verbindung mit 4 justierbaren Gleitlagern garantieren einen perfekte Sitz und bestes Gleitvermögen.
- **Die Kraftübertragung zwischen den Spindeln erfolgt durch eine Kette mit elektrischer Kettenspannungs-Überwachung um leiseste Funktion bei höchster Elastizität zu gewährleisten.**
- Elektrische Anlage entsprechend den EEC-Normen, "Stand-by-Sicherung".
- Epoxid-Pulverbeschichtung.
- Säulen werksseitig vormontiert.
- Ausgestattet mit Fettschmierung.
- Ausgestattet mit schmaler Grundplatte.

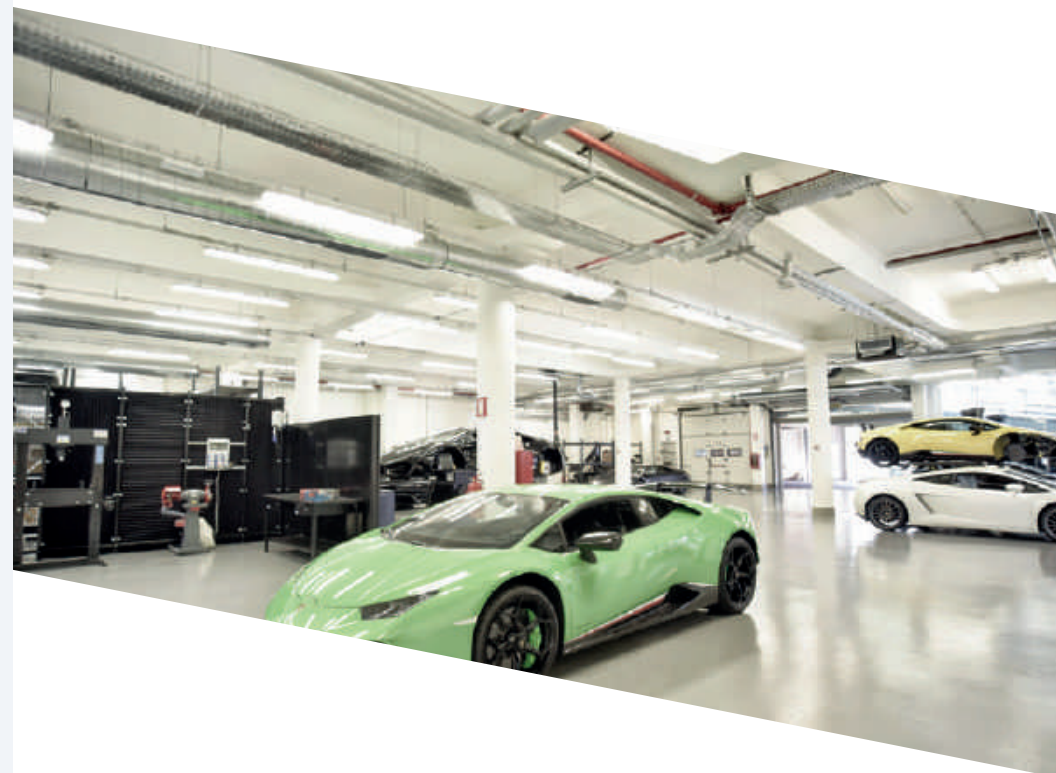



ART. 199/T • 199/U

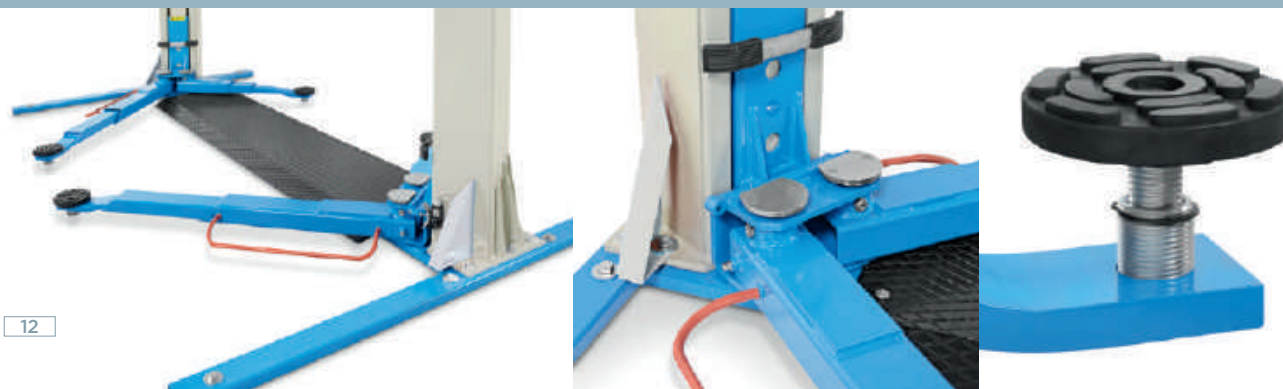
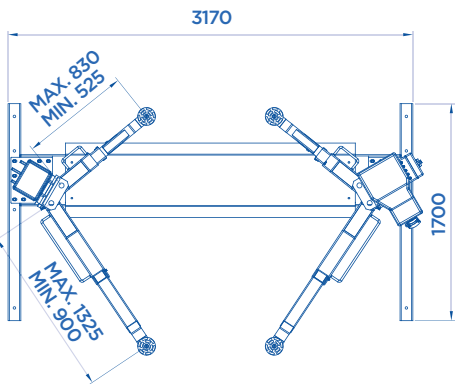
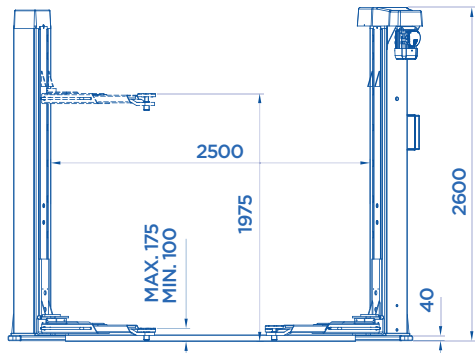

**2800**  
**3200** **KG**



**OPTIONAL** Pag. 025

ART.			Motore trifase Three-phase motor Moteur triphasé Netzspannung	
<b>199/T</b>	2800 Kg	2,6 KW	400V • 50HZ	750
<b>199/U</b>	3200 Kg	3,3 KW	400V • 50HZ	775

 Potenza motore • Motor power • Puissance moteur • Motorleistung

ART. 199/TE • 199/UE



2800  
3200 | **KG**

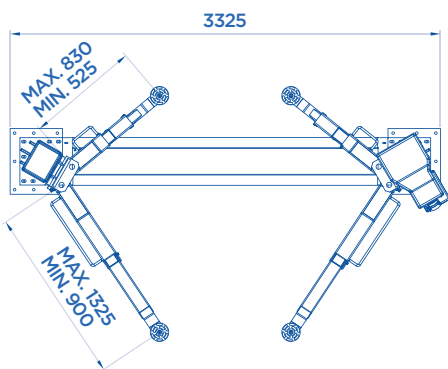
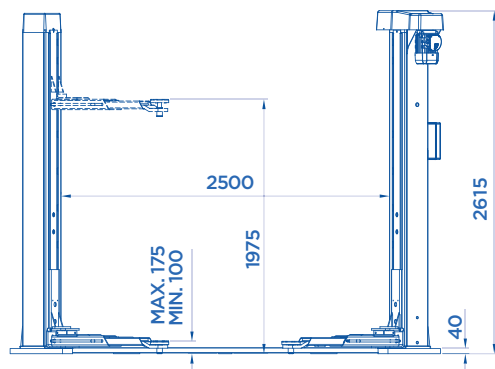

**OPTIONAL** Pag. 025

ART.



Motore trifase  
Three-phase motor  
Moteur triphasé  
Netzspannung



199/TE	2800 Kg	2,6 KW	400V • 50HZ	730
199/UE	3200 Kg	3,3 KW	400V • 50HZ	755

 Potenza motore • Motor power • Puissance moteur • Motorleistung

ART. 199/DELTA



**3500 KG**

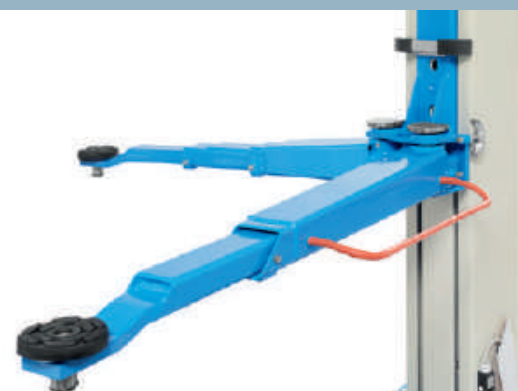
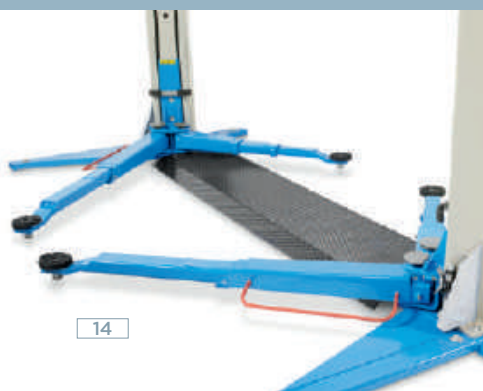
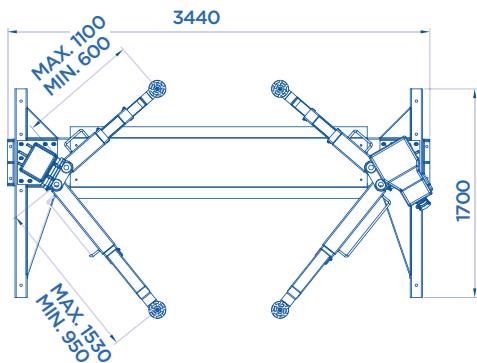
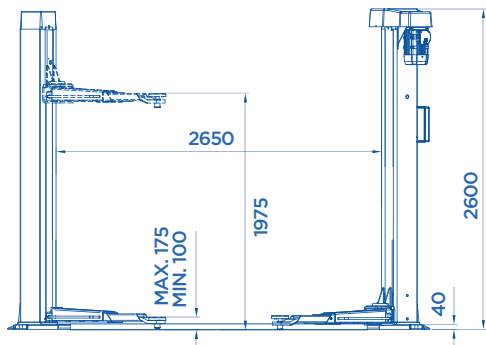

**OPTIONAL** Pag. 025

<b>ART.</b>			Motore trifase Three-phase motor Moteur triphasé Netzspannung	
-------------	---	---	--	---

**199/DELTA** | 3500 Kg | 4 KW | 400V • 50HZ | 850

 Potenza motore • Motor power • Puissance moteur • Motorleistung

ART. 199/BETA

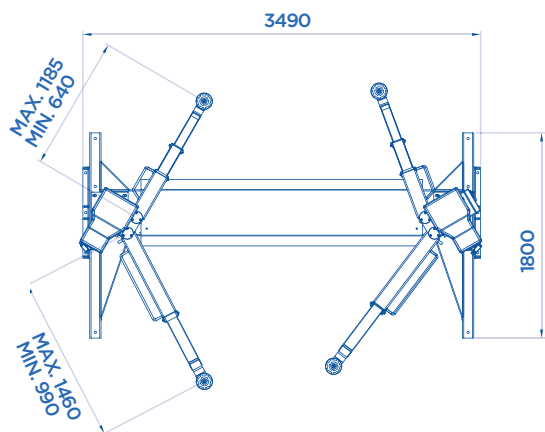
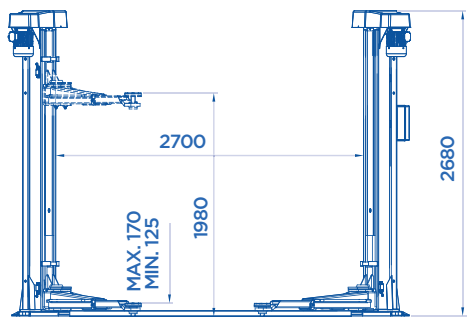

4000 KG



\* **+ OPTIONAL**

ART. 373  
SET DI PROLUNGHE

Pair of extensions  
Paire de rallonges  
2 Verlängerungen

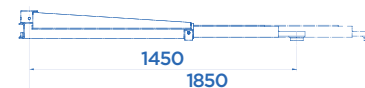

600 Kg X 2

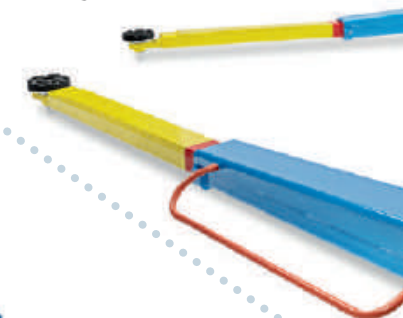

**OPTIONAL** Pag. 025

ART.



Motore trifase  
Three-phase motor  
Moteur triphasé  
Netzspannung



199/BETA | 4000 Kg | 2,6+2,6 KW | 400V • 50HZ | 950

 Potenza motore • Motor power • Puissance moteur • Motorleistung





## PONTI SOLLEVATORI ELETTROMECCANICI A 2 COLONNE

### ELECTROMECHANICAL 2-POST LIFTS

#### TRACCIATO TECNICO COSTRUTTIVO

- Funzionamento elettromeccanico.
- Sollevamento a mezzo viti trapezoidali rullate, in acciaio ad alta resistenza, a passo fine per rendere autofrenanti i carrelli.
- Carrelli a scorrimento interno, completamente protetti.
- Chiocciole portanti in materiale speciale, onde ridurre al minimo la lubrificazione.
- Chiocciole di sicurezza autoprotette.
- Struttura colonna monoscocca.
- Quattro rulli di scorrimento per ogni singolo carrello più quattro pattini registrabili garantiscono una perfetta aderenza e scorrevolezza.
- **Sincronizzazione tra i due carrelli controllata da dispositivo elettronico che comanda il riallineamento dopo una differenza superiore ai 15 mm.**
- Motore elettrico sovradimensionato con protezione termica.
- Impianto elettrico a circuito chiuso, con comandi e fine corsa a bassa tensione, funzionamento "uomo presente".
- Verniciatura a polvere epossidica.
- Struttura completamente premontata.
- Pompetta di ingrassaggio in dotazione.
- Tasselli di ancoraggio al suolo in dotazione.

#### TECHNICAL AND STRUCTURAL LAY-OUT

- Electromechanical operating.
- Lifting through trapezoidal turning screws, made of high resistance steel with fine pitch so that trolleys may become self-braking.
- Completely protected internal sliding trolleys.
- Load-bearing nuts from a special material, to minimise lubrication.
- Self-protected safety nuts.
- Monocoque body column structure.
- Four sliding rollers for each trolley, plus four adjustable guide-shoes guarantee a perfect adhesion and flowability.
- **Synchronization between the two trolleys regulated by electronic device which controls the re-alignment after a difference of more than 15 mm.**
- Over-sized electric motor with thermic protection.
- Closed-course electrical system, with low-voltage drives and endstrokes, "man standing-by" operating.
- Epoxy powder painting.
- Completely pre-assembled frame.
- Equipped with greasing pump.
- Equipped with anchor small blocks.



# PONTS ELEVATEURS A 2 COLONNES ELECTROMECHANIQUES

## ELEKTROMECHANISCHE 2-SÄULEN HEBEBÜHNEN

### RELEVÉ TECHNIQUE

- Fonctionnement électromécanique.
- Levage par vis trapézoïdales comprimées, en acier haute résistance. Pas de vis fin pour des chariots auto-freinants.
- Chariots internes coulissants entièrement protégés.
- Ecrous portants en matériel spécial, qui réduit au minimum le graissage.
- Ecrous de sécurité autoprotégés.
- Structure colonne en monocoque.
- Quatre roulements coulissants permettent la course de chaque chariot et quatre patins réglables en garantissent une parfaite adhésion et la mobilité.
- **Synchronisme supervisé par un dispositif électronique qui ordonne le réalignement dès que le décalage des chariots dépasse 15 mm.**
- Moteur électrique surdimensionné avec protection thermique.
- Installation électrique à circuit fermé, commandes et fins de courses basse tension, commandes de type "homme mort".
- Peinture époxy.
- Structure entièrement assemblée en usine.
- Poire de graissage fournie.
- Chevilles d'ancrage au sol fournies.

### TECHNISCHE UND KONSTRUKTIVE ANGABEN

- Elektromechanischer Betrieb.
- Hub erfolgt mittels Trapezgewinde-Spindeln aus Spezialstahl; Abbremsen der Hubschlitten durch selbsthemmende Spindelgewinde.
- Völlig geschützte innenliegende Führungen.
- Tragmuttern aus speziellen Material, um die Schmierung auf ein Minimum zu reduzieren.
- Selbstsichernde Folgemutter.
- Äußerst stabile Konstruktion.
- 4 kugelgelagerte Rollen an jedem Hubschlitten in Verbindung mit 4 justierbaren Gleitlagern garantieren einen perfekte Sitz und bestes Gleitvermögen.
- **Die Synchronisation der 2 Hubschlitten wird von einer elektronischen Vorrichtung überwacht und automatisch reguliert, wenn der Höhenunterschied mehr als 15 mm beträgt.**
- Elektrische Anlage entsprechend den EEC-Normen, "Stand-by-Sicherung".
- Epoxid-Pulverbeschichtung.
- Säulen werkseitig vormontiert.
- Ausgestattet mit Fettschmierung.
- Ausgestattet mit schmaler Grundplatte.



ART. 199/R



5500 KG



ART. 199/RL

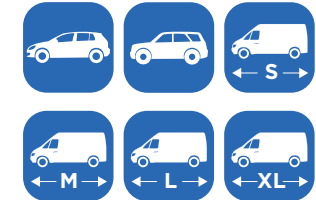

ART. 199/R

## TRACCIATO TECNICO COSTRUTTIVO

- Chiocciola portante in bronzo abbinata ad una seconda chiocciola di sicurezza di pari altezza, autoprotetta da sicurezza elettrica.
- Carrelli a scorrimento interno, completamente protetti.
- Guide di scorrimento in acciaio trafilato pieno ad alta resistenza.
- **Sei ruote di grosso diametro in acciaio ad alta resistenza per ogni carrello, garantiscono una perfetta aderenza e scorrevolezza.**
- Lubrificazione delle viti assicurata da un sistema montato direttamente sulla chiocciola portante.
- Sincronizzazione tra i due carrelli controllata da dispositivo elettronico che comanda il riallineamento dopo una differenza superiore ai 15 mm.
- Tasselli di ancoraggio al suolo in dotazione.

## TECHNICAL AND STRUCTURAL LAY-OUT

- Bronze bearing nut together with a second safety nut of the same height, selfprotected by electric safety.
- Completely protected internal sliding trolleys.
- Slides in full drawn solid steel at high resistance.
- **Six wheels with big diameter and in high-resistance steel for each trolley guarantee a perfect adhesion an flowability.**
- Lubrification of the screws assured by a device mounted directly on the bearing nut.
- Synchronization between the two trolleys regulated by electronic device which controls the re-alignment after a difference of more than 15 mm.
- Equipped with anchor small blocks.

## RELEVÉ TECHNIQUE

- Ecroû porteur en bronze couplé à un second écrou de sécurité autoprotégé par sécurité électrique.
- Chariots internes coulissants entièrement protégés.
- Guides coulissants en acier trempé plein haute résistance.
- **Chariots montés sur 6 roues de grand diamètre en acier haute résistance pour une adhérence et un déplacement parfait.**
- Lubrification des vis assurée par un dispositif monté directement sur les écrous porteurs.
- Synchronisme supervisé par un dispositif électronique qui ordonne le réalignement dès que le décalage des chariots dépasse 15 mm.
- Chevilles d'ancrage au sol fournies.

## TECHNISCHE UND KONSTRUKTIVE ANGABEN

- Zwei gleich hohe Tragmuttern aus Lagerbronze, einmal in Funktion als Sicherheitsmutter. Elektrische Sicherheitsabschaltung bei Tragmutter Schaden.
- Völlig geschützte innenliegende Führungen.
- Gleitbahnen aus gehärtetem, hochfestem Stahl.
- **6 Räder mit großem Durchmesser und aus hochfestem Stahl gefertigt, garantieren eine gute Haftung sowie hervorragende Laufeigenschaften.**
- Die Schmierung der Muttern erfolgt durch eine spezielle, direkt auf der Tragmutter angebrachten Schmierungsvorrichtung.
- Die Synchronisation der 2 Hubschlitzen wird von einer elektronischen Vorrichtung überwacht und automatisch reguliert, wenn der Höhenunterschied mehr als 15 mm. beträgt.
- Ausgestattet mit schmaler Grundplatte.

ART. 199/R

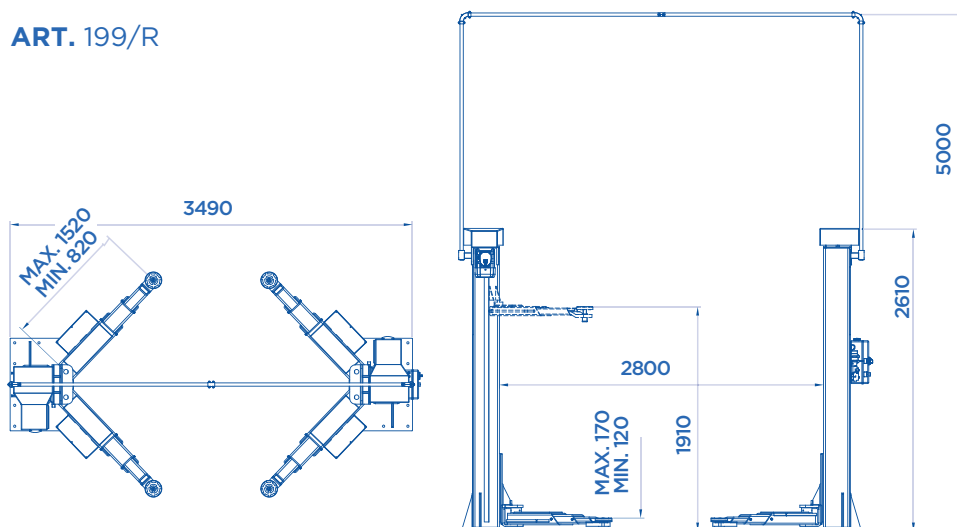

ART. 199/RL

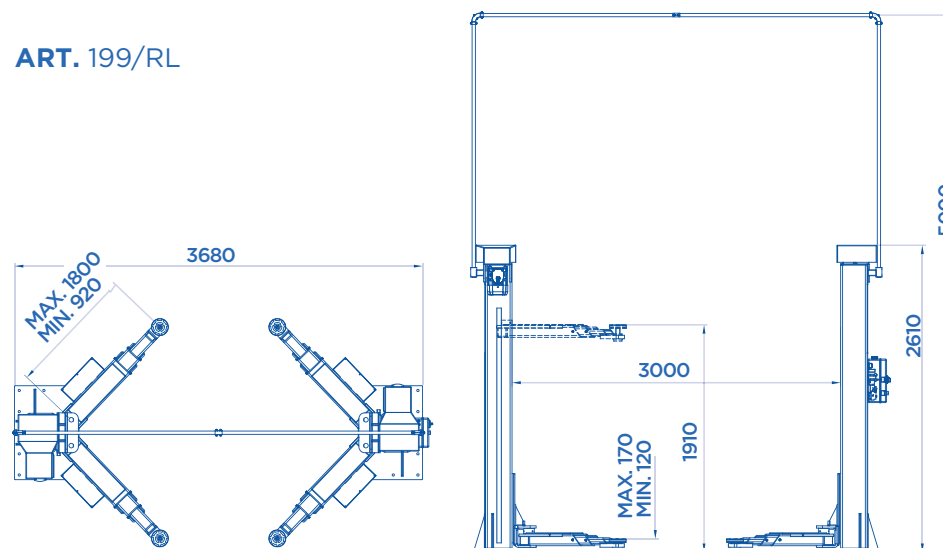

### OPTIONAL Pag. 025

ART.			Motore trifase Three-phase motor Moteur triphasé Netzspannung	
199/R	5500 Kg	3,3+3,3 KW	400V • 50HZ	1270

Potenza motore • Motor power • Puissance moteur • Motorleistung

### OPTIONAL Pag. 025

ART.			Motore trifase Three-phase motor Moteur triphasé Netzspannung	
199/RL	5500 Kg	3,3+3,3 KW	400V • 50HZ	1300



ART. 199/RX • 199/RV



5500 | 6000 **KG**

*All-in One*

## TRACCIATO TECNICO COSTRUTTIVO

- **Bracci a snodo multiplo per sollevare dalla Smart fino al furgone a passo lungo.**
- La soluzione universale per tutto il parco circolante odierno.
- Luce utile tra le colonne di ben 3 metri.
- Struttura colonna monococca per la massima robustezza.
- Motori autoventilati dotati di protezione per evitare surriscaldamenti.
- Gestione del livellamento tra i due carrelli tramite scheda elettronica con autocheck guasti incorporato che non richiede manutenzione.
- Scorrimento del carrello su 6 ruote in acciaio per la massima stabilità in ogni condizione di carico.

## TECHNICAL AND STRUCTURAL LAY-OUT

- **Multiple joint arms to lift from the Smart to the long wheelbase truck.**
- The universal solution for the whole of today's fleet.
- 3 metres clearance between columns.
- Monobloc column structure for maximum sturdiness.
- Self-cooling motors with protection to avoid overheating.
- Management of levelling between the two carriages by electronic card with maintenance-free built-in fault autocheck.
- Carriage sliding on 6 steel wheels for maximum stability in all load conditions.

## RELEVÉ TECHNIQUE

- **Bras à articulation multiple pour le levage de véhicules de la Smart jusqu'au fourgon à entraxe long.**
- La solution universelle pour tout le parc de véhicules aujourd'hui en circulation.
- Espace utile entre les colonnes de 3 mètres.
- Structure colonne monocoque pour une robustesse maximum.
- Moteurs auto-ventilés munis d'une protection pour empêcher les surchauffes.
- Synchronisation des chariots par carte électronique à diagnostique embarqué des pannes. Zéro entretien.
- Déplacement du chariot sur 6 galets en acier pour une stabilité maximum dans toutes les conditions de chargement.

## TECHNISCHE UND KONSTRUKTIVE ANGABEN

- **Mehrgelenkarme die im Stande sind vom Smart bis hin zum Lieferwagen mit großem Achsabstand zu heben.**
- Die universelle Lösung für den gesamten, sich im Verkehr befindlichen, Fahrzeugpark.
- Lichtes Nutzmaß zwischen den Säulen von über 3 Metern.
- Struktur mit selbsttragender Säule für maximale Stabilität.
- Eigenbelüftete Motoren die über einen Schutz verfügen, um ein Überhitzen zu vermeiden.
- Die Einstellung der Gleichsetzung zwischen den beiden Schritten erfolgt über eine elektronische Karte mit eingebautem Selbstcheck von Fehlern, der keine Wartung benötigt.
- Gleitbewegung des Schlittens auf 6 Stahlrädern für eine maximale Stabilität in jeder Ladesituation.

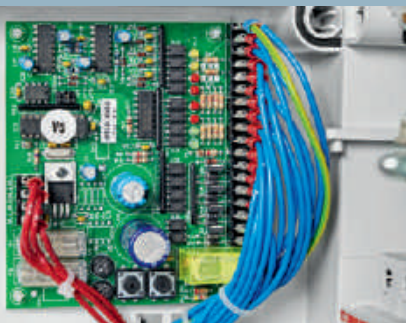
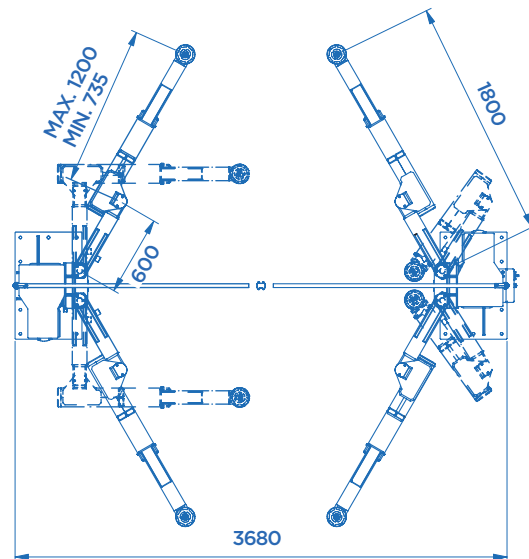
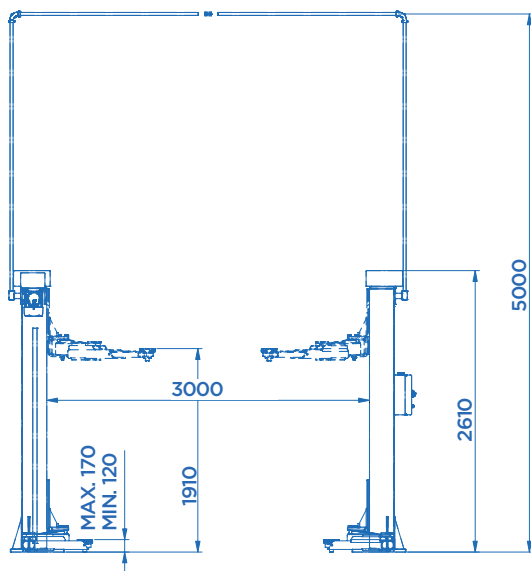

### OPTIONAL Pag. 025

ART.			Motore trifase Three-phase motor Moteur triphasé Netzspannung	
199/RX	5500 Kg	3,3+3,3 KW	400V • 50HZ	1480
199/RY	6000 Kg	3,5+3,5 KW	400V • 50HZ	1530
	Potenza motore • Motor power • Puissance moteur • Motorleistung			

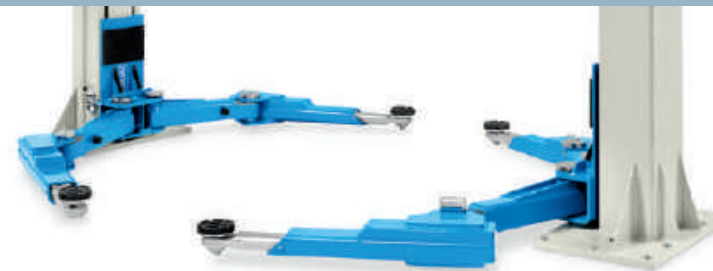



ART. 199/DK • 199/GK



2800  
3200 | **KG**

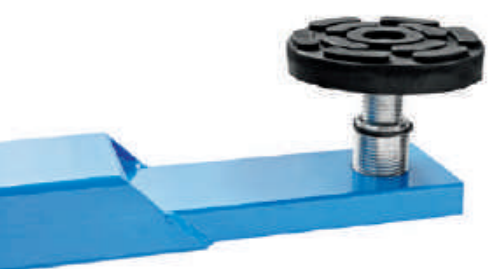
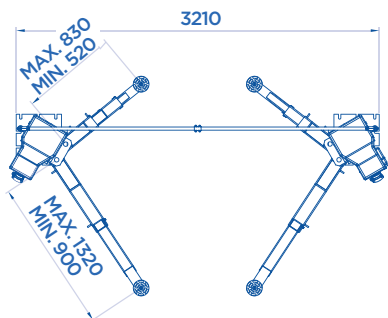
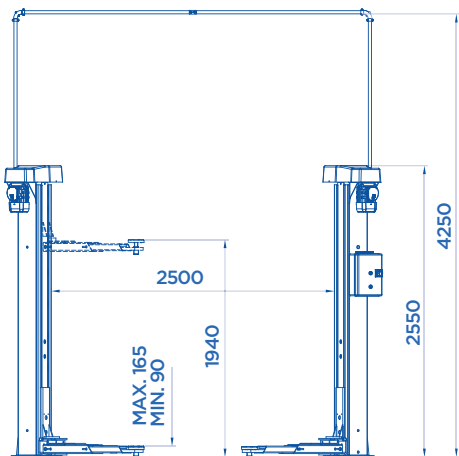

**OPTIONAL** Pag. 025

ART.			Motore trifase Three-phase motor Moteur triphasé Netzspannung	
199/DK	2800 Kg	1,5+1,5 KW	400V • 50HZ	720
199/GK	3200 Kg	2+2 KW	400V • 50HZ	760

Potenza motore • Motor power • Puissance moteur • Motorleistung

ART. 199/GAMMA



3500 KG

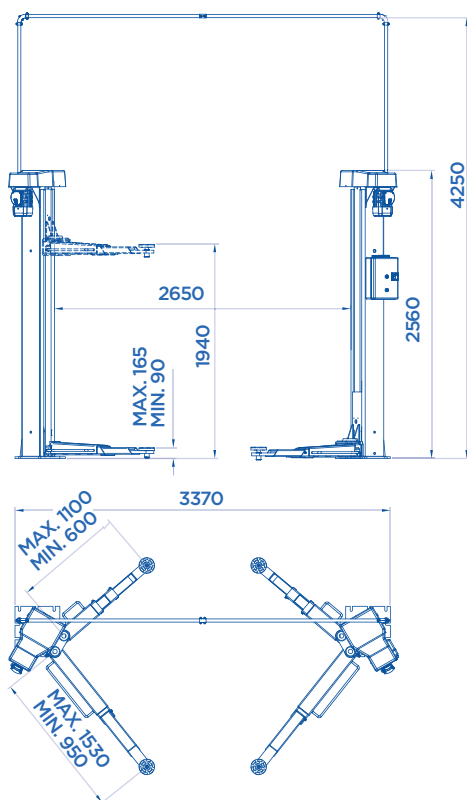

OPTIONAL Pag. 025

ART.			Motore trifase Three-phase motor Moteur triphasé Netzspannung	
------	---	---	--	---

199/GAMMA | 3500 Kg | 2,6+2,6 KW | 400V • 50HZ | 820

 Potenza motore • Motor power • Puissance moteur • Motorleistung



**ART. 199/ALFA**

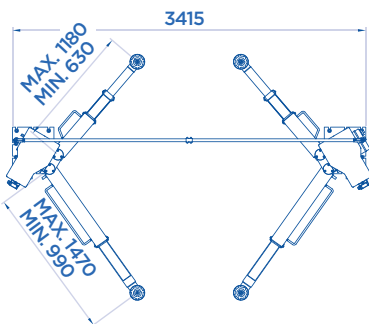
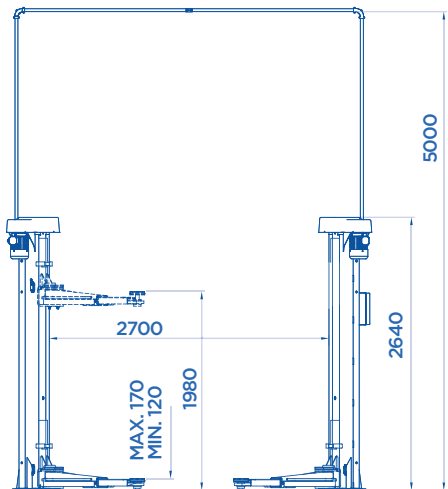

**4000 KG**



\* **+ OPTIONAL**

**ART. 373 SET DI PROLUNGHE**

Pair of extensions  
Paire de rallonges  
2 Verlängerungen

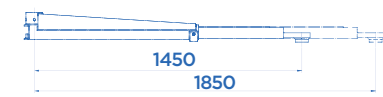

600 Kg X 2

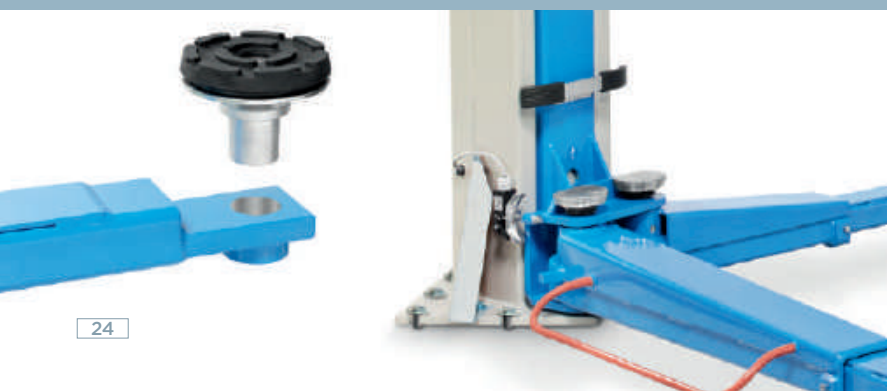
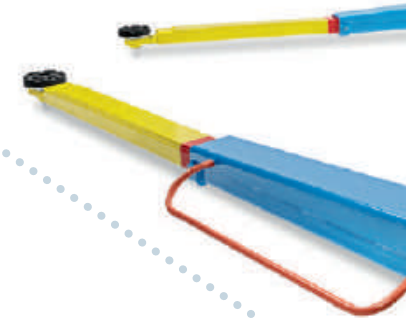

**OPTIONAL** Pag. 025

<b>ART.</b>			Motore trifase Three-phase motor Moteur triphasé Netzspannung	
-------------	---	---	--	---

**199/ALFA** | 4000 Kg | 2,6+2,6 KW | 400V • 50HZ | 850

 Potenza motore • Motor power • Puissance moteur • Motorleistung

**ACCESSORI EXTRA DOTAZIONE**  
EXTRA EQUIPMENT • ACCESSOIRES EN OPTION • EXTRA ZUBEHÖR

**KIT** **X4**

**ADATTATORI**

Adaptors  
Adaptateurs  
Adapter

ART.	mm	199/T • 199/U 199/TE • 199/UE 199/DELTA	199/DK • 199/GK 199/GAMMA
<b>370</b>	250	✓	✓
<b>370/A</b>	380	✓	✓
<b>370/B</b>	65	✓	✓
<b>370/C</b>	45	✓	✓
<b>370/D</b>			



ART. 370/D

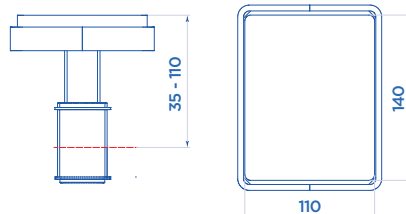

ART. 370



ART. 370/A



ART. 370/B



ART. 370/C

## ACCESSORI EXTRA DOTAZIONE

EXTRA EQUIPMENT • ACCESSOIRES EN OPTION • EXTRA ZUBEHÖR

### KIT

#### ADATTATORI

Adaptors  
Adaptateurs  
Adapter

ART.	199/BETA	199/ALFA 199/R • 199/RL 199/RX • 199/R
A199/R	✓	✓
B199/R	✓	✓
C199/R	✓	✓
D199/R	✓	✓
E199/R	✓	✓
G199/R	✓	✓
H199/R	✓	✓

#### ART. G199/R

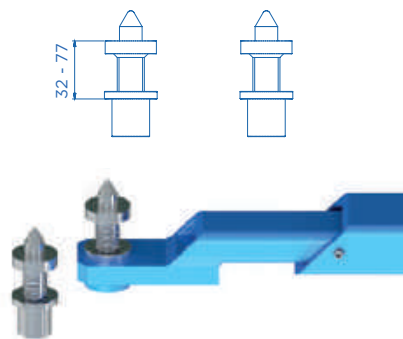

#### ART. H199/R

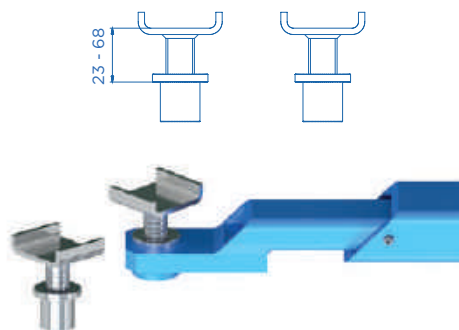

#### ART. D199/R

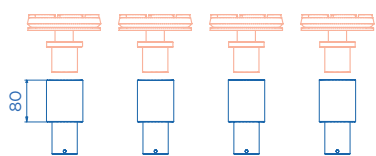

#### ART. E199/R

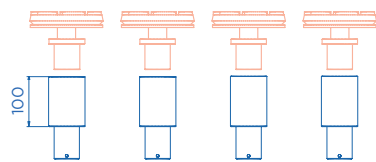

#### ART. A199/R

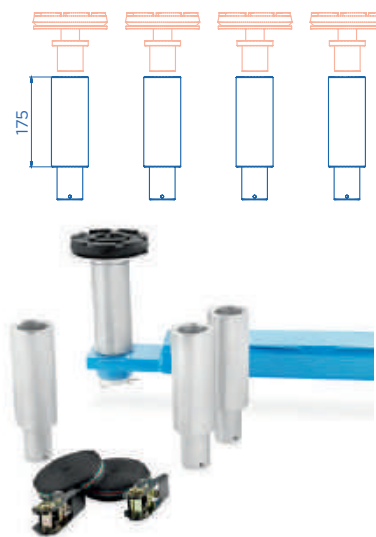

#### ART. B199/R



#### ART. C199/R

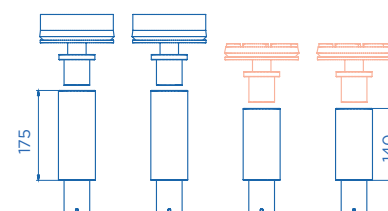

## TRACCIATO TECNICO COSTRUTTIVO

- Speciali forche per sollevare il veicolo dalle ruote ed avere il sottoscocca completamente libero.
- Indispensabili in caso di rimozione pacco batterie dal basso.
- Installazione estremamente facile: si rimuovono i tamponi forniti di serie con il sollevatore e si installano le forche.
- Utilizzo al bisogno senza necessità di acquistare un sollevatore dedicato.
- Forche dotate di rulli su cuscinetti per permettere la rotazione della ruota.

## TECHNICAL AND STRUCTURAL LAY-OUT

- Special forks to lift the vehicle from under the wheels and allow free access to the underbody.
- Mandatory to remove the battery group from below.
- Easy to install: just take the pads off and put the forks instead.
- Use it when you need it: no need to buy a new lift just for that use.
- The forks have rolls with bearings inside so that the wheel can roll freely.

## RELEVÉ TECHNIQUE

- Fourches spéciales pour soulever le véhicule par les roues afin de libérer complètement l'accès aux bas de caisse.
- Indispensable pour enlever le groupe batterie par le bas.
- Montage ultra facile : il suffit de retirer les tampons fournis avec le pont et de monter les fourches à leur place.
- Utilisez-les quand vous le souhaitez: nul besoin de faire l'achat d'un pont uniquement pour cet usage.
- Fourches dotées de rouleaux montés sur roulements pour que la roue tourne librement.

## TECHNISCHE UND KONSTRUKTIVE ANGABEN

- Spezielle Gabeln, um das Fahrzeug von den Rädern anzuheben und den Unterboden komplett frei zu haben.
- Unverzichtbar bei der Entnahme des Akkupacks von unten.
- Unkomplizierte Installation: Einfach die vormontierten Doppelhubpuffer entfernen und die Gabeln anbringen.
- Verwendung nach Bedarf, ohne dass eine extra Bühne gekauft werden muss.
- Gabeln mit gelagerten Rollen, die die Drehung des Rades ermöglichen.

## ART. N199/RX

ART.  199/RX  
N199/RX | 1000 Kg X 4 | 

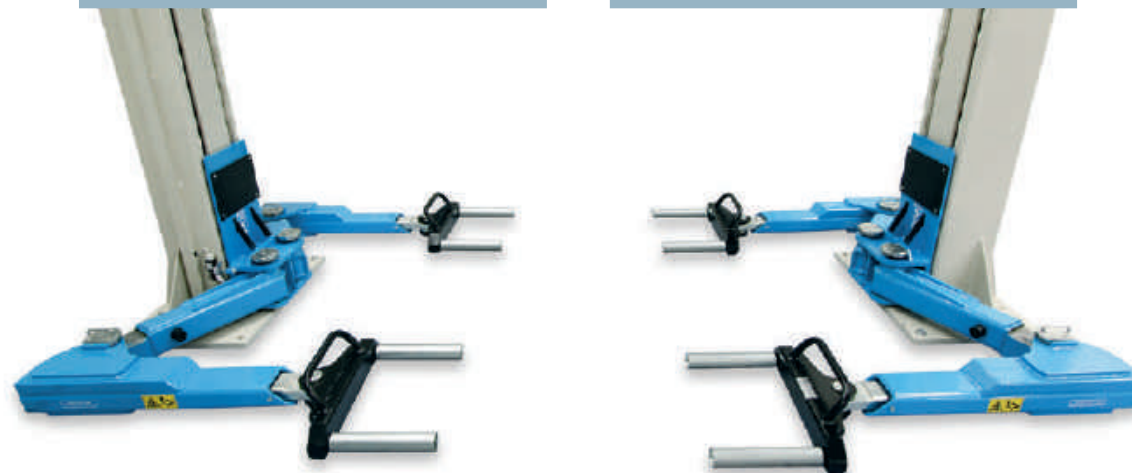
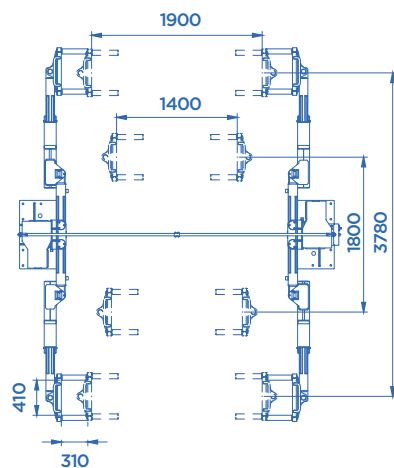
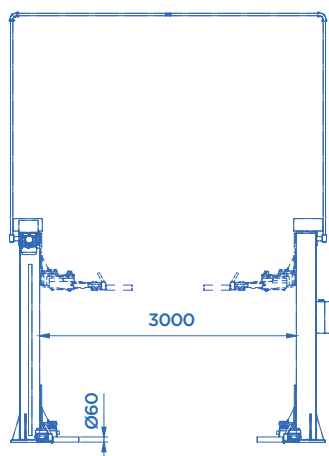

## ACCESSORI EXTRA DOTAZIONE

EXTRA EQUIPMENT • ACCESSOIRES EN OPTION • EXTRA ZUBEHÖR

### ART. 371 DUE COPPIE DI CAVALLETTI PER ASSETTO RUOTE PER PONTE SOLLEVATORE A DUE COLONNE

Two pairs of wheel alignment stands for two post lifts  
Deux paires de chevalets pour la géométrie des roues sur pont 2 colonnes  
2 Paar fahrbare Unterstellböcke zur Achsvermessung für 2-Säulen Hebebühnen



### ART. 373 SET DI PROLUNGHE

Pair of extensions  
Paire de rallonges  
2 Verlängerungen

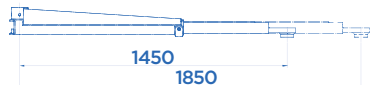

ART.

373



600 Kg X 2

199/BETA  
199/ALFA



### ART. 372 TAMPONE A REGOLAZIONE RAPIDA



Fast adjustable pad  
Tampon à réglage rapide  
Pufferhalterung mit  
Schnelleinstellung

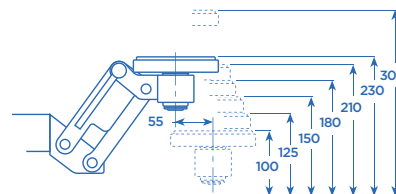

✓ ART. 199/T • 199/U • 199/TE • 199/UE  
• 199/DELTA

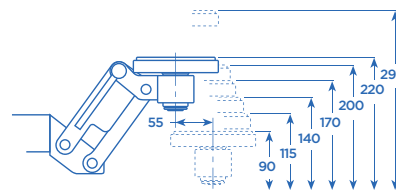

✓ ART. 199/DK • 199/GK • 199/GAMMA

- Diverse posizioni stabili ad aggancio automatico.
- Tampone regolabile a vite a doppia sfilata.
- Una facilità di utilizzo, regolazione e posizionamento.

- Different stable positions for automatic coupling.
- Double stage screw adjustable pads.
- Easy to use, adjust and position.

- Différentes positions stables à accrochage automatique.
- Tampon réglable à vis à double étage.
- La facilité d'utilisation, de réglage, et de positionnement.

- Verschiedene feste Positionen mit automatischer Aufnahme.
- Puffer mit Schraubeinstellung und mit doppeltem Lauf.
- Die Einfachheit im Gebrauch, der Einstellung und Positionierung.

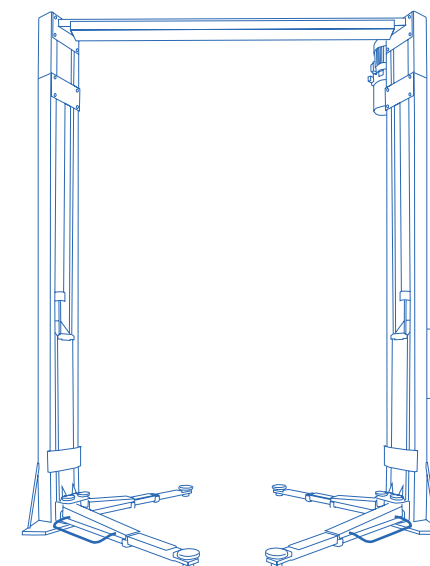

## **PONTI SOLLEVATORI ELETTRIDRAULICI A 2 COLONNE**

ELECTROHYDRAULIC 2-POST LIFTS  
PONTIS ELEVATEURS A 2 COLONNES ELECTROHYDRAULIQUES  
ELEKTROHYDRAULISCHE 2-SÄULEN HEBEBÜHNEN

Made in Italy 



# PONTS ELEVATEURS A 2 COLONNES ELECTROHYDRAULIQUES

## ELEKTROHYDRAULISCHE 2-SÄULEN HEBEBÜHNEN

### RELEVÉ TECHNIQUE

- Fonctionnement électrohydraulique.
- **Entretien réduit au minimum grâce à la longévité des composants de l'élevateur et à l'absence totale de câble, chaînes, poulies, roulements, vis et écrous.**
- Alignement et synchronisme des deux chariots indépendamment de la répartition de charge.
- Appuis mécaniques de sécurité à branchement automatique.
- Soupapes de sécurité intégrées aux cylindres.
- Dispositif de sécurité en présence d'obstacles pendant la phase de descente.
- Contrôle compensé de la vitesse.
- Vanne de protection contre les surcharges.
- Protège-pieds et dispositif automatique de blocage des bras.
- Commandes de type "homme mort" basse tension 24 V.
- Dispositif anticollision du véhicule sur la traverse supérieure.
- Peinture époxy.
- Chevilles d'ancrage au sol fournies.
- Livrés avec l'huile pour le circuit hydraulique.

### TECHNISCHE UND KONSTRUKTIVE ANGABEN

- Elektrohydraulischer Antrieb.
- **Die Wartung wurde auf ein Minimum reduziert wegen Verwendung sehr hochwertiger Bauteile sowie dem völligen Fehlen mechanischer Bauteile wie Seile, Ketten, Lagern und Tragmütern.**
- Anpassung und Synchronisation der Hubschlitten, unabhängig von der Verteilung der Ladung.
- Automatisches Einrasten der mechanischen Sicherheitsvorrichtung.
- Im Zylinder eingebaute Sicherheitsventile.
- Senkabschaltung beim Auflaufen auf ein Hindernis.
- Überwachung der Hub-/Senkgeschwindigkeit.
- Überlastventil.
- Fußschutz und automatische Tragamarretierung.
- Totmann-Steuerung (Niederpassung).
- Ausgestattet mit einer Sicherheitsabschaltung an der oberen Travese.
- Epoxid-Pulverlackierung.
- Ausgestattet mit schmaler Grundplatte.
- Wird mit Öl für die hydraulische Schaltung geliefert.

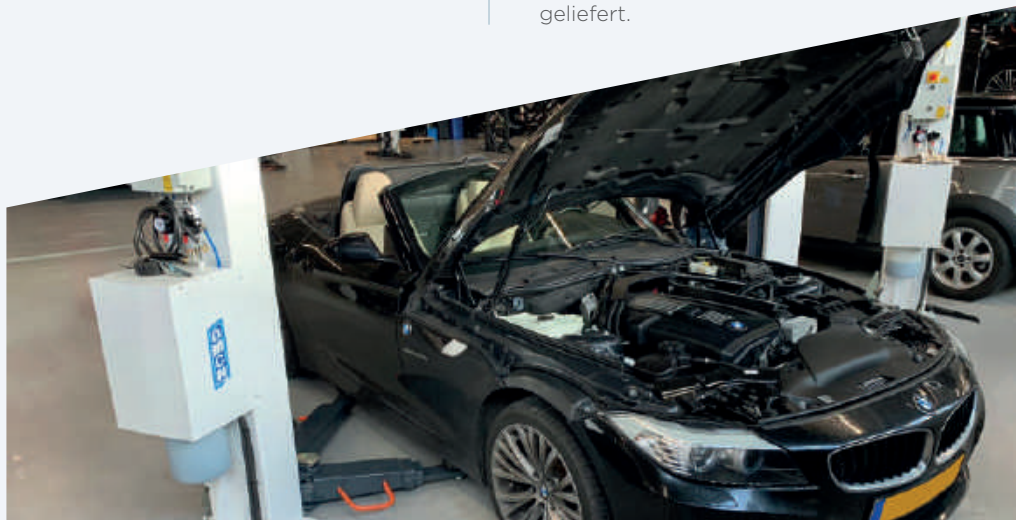





ART. 199/YL



3200 KG

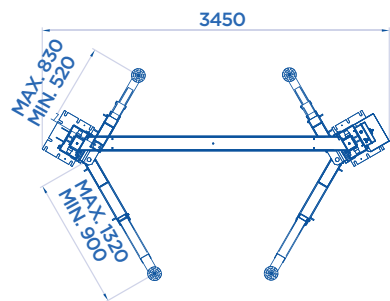
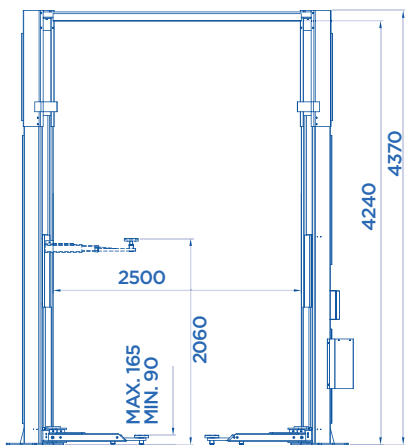

32

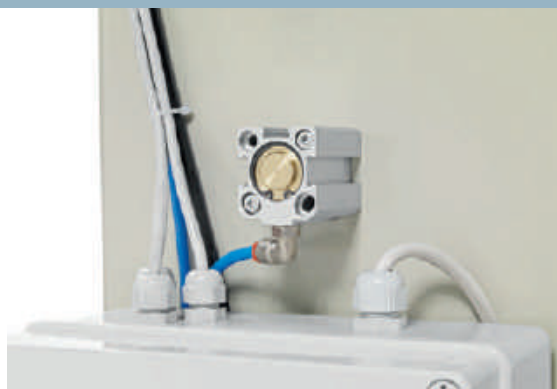

OPTIONAL Pag. 038

ART.			Motore trifase Three-phase motor Moteur triphasé Netzspannung	
199/YL	3200 Kg	2,2 KW	400V • 50HZ	770
Potenza motore • Motor power • Puissance moteur • Motorleistung				



ART. 199/YP

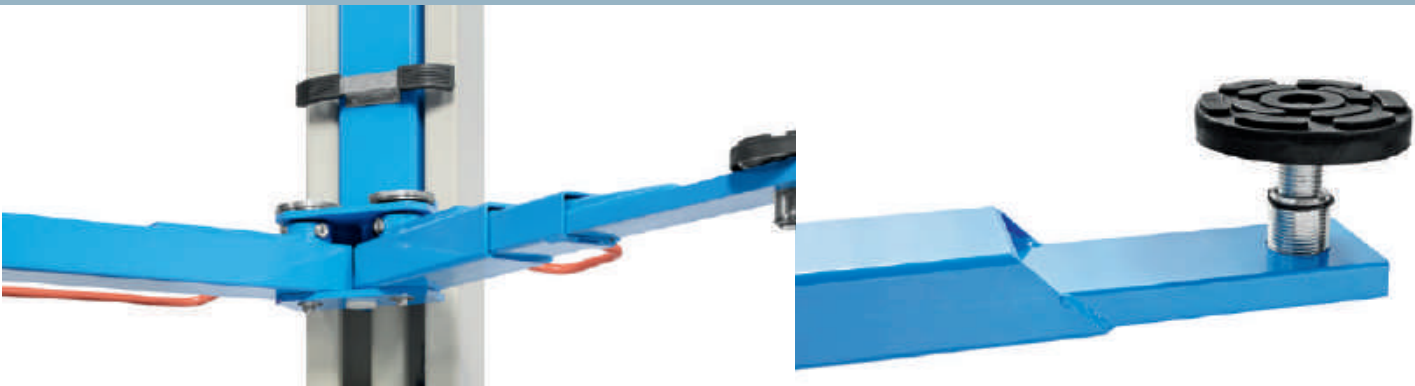
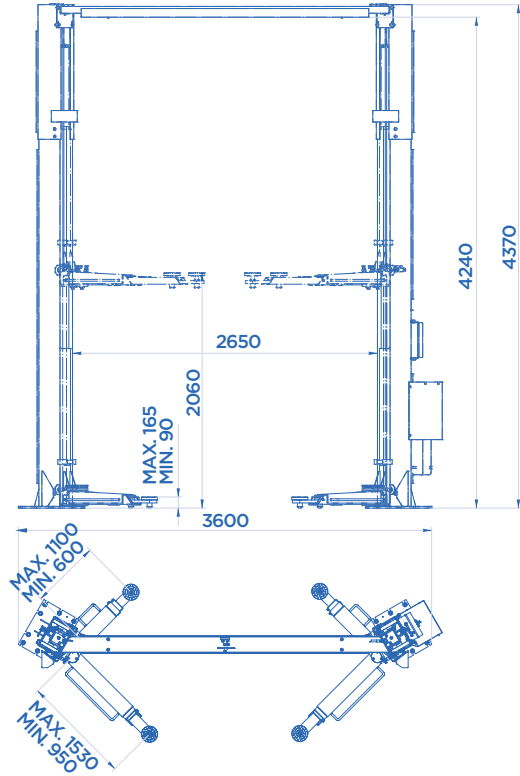

3500 KG



OPTIONAL Pag. 038

ART.			Motore trifase Three-phase motor Moteur triphasé Netzspannung	
199/YP	3500 Kg	2,2 KW	400V • 50HZ	820

 Potenza motore • Motor power • Puissance moteur • Motorleistung

ART. 199/V • 199/W • 199/X

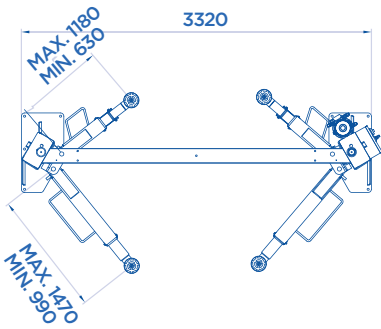
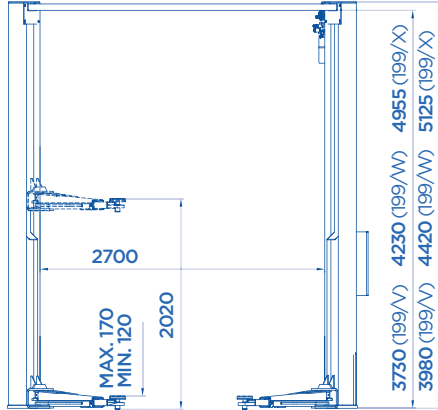

\* **+ OPTIONAL**

**ART. 373  
SET DI PROLUNGHE**

Pair of extensions  
Paire de rallonges  
2 Verlängerungen



600 Kg X 2



**OPTIONAL** Pag. 038

ART.



Motore trifase  
Three-phase motor  
Moteur triphasé  
Netzspannung



<b>199/V</b>	4000 Kg	2,2 KW	400V • 50HZ	940
<b>199/W</b>	4000 Kg	2,2 KW	400V • 50HZ	1000
<b>199/X</b>	4000 Kg	2,2 KW	400V • 50HZ	1020

 Potenza motore • Motor power • Puissance moteur • Motorleistung

ART. 199/WRX

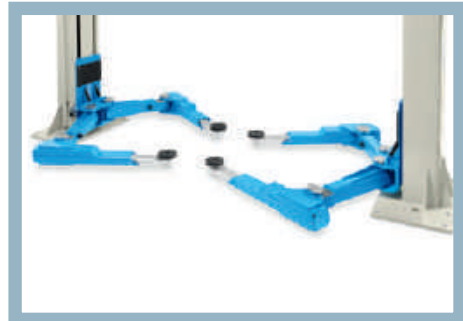
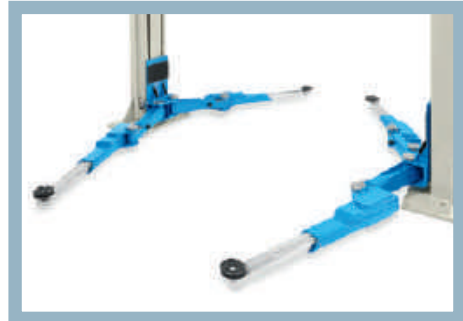
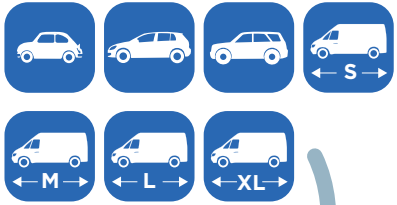

5500 KG

All-In One



ART. 199/WRL

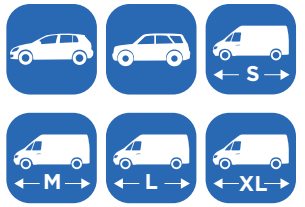

ART. 199/WRX

## TRACCIATO TECNICO COSTRUTTIVO

- Bracci a snodo multiplo per sollevare dalla Smart fino al furgone a passo lungo (199/WRX).
- La soluzione universale per tutto il parco circolante odierno (199/WRX).
- Sbocco e riarmo delle sicurezze completamente automatico (senza leva manuale).
- Centrale oleodinamica posta in alto per ridurre l'ingombro nella zona di lavoro.
- Luce utile tra le colonne di ben 3 metri.
- Struttura colonna monoscocca per la massima robustezza.
- **Sollevamento tramite 2 cilindri idraulici: assenza totale di funi, catene, pulegge, o altri organi meccanici che richiedono una costante manutenzione.**
- Gestione del livellamento tra i due carrelli tramite unità logica (PLC) di gestione.

## TECHNICAL AND STRUCTURAL LAY-OUT

- Multiple joint arms to lift from the Smart to the long wheelbase truck (199/WRX).
- The universal solution for the whole of today's fleet (199/WRX).
- Safety devices are released and reset completely automatically (without manual lever).
- Hydraulic unit placed at top to save space in operating area.
- 3 meters clearance between columns.
- Monobloc column structure for maximum sturdiness.
- **Lifting by two hydraulic cylinders: total absence of cables, chains, pulleys or other mechanical parts requiring constant maintenance.**
- Levelling between the two carriages ensured by a management logic unit (PLC).

## RELEVÉ TECHNIQUE

- Bras à articulation multiple pour le levage de véhicules de la Smart jusqu' au fourgon à entra-xe long (199/WRX).
- La solution universelle pour tout le parc de véhicules aujourd'hui en circulation (199/WRX).
- Déblocage et ré-enclenchement des sécurités entièrement automatique (sans levier manuel).
- Centrale oléo-dynamique située en haut pour réduire l'encombrement dans la zone de travail.
- Espace utile entre les colonnes de 3 mètres.
- Structure colonne monocoque pour une robuste-esse maximum.
- **Levage par le biais de 2 vérins hydrauliques : absence totale de cordes, chaînes, poulies ou autres organes mécaniques exigeant un entre-tien constant.**
- Gestion de nivellement entre les deux chariots au moyen d'un automate (API) de gestion.

## TECHNISCHE UND KONSTRUKTIVE ANGABEN

- Mehrgelenkarme die im Stande sind vom Smart bis hin zum Lieferwagen mit großem Achsabstand zu heben (199/WRX).
- Die universelle Lösung für den gesamten, sich im Verkehr befindlichen, Fahrzeugpark (199/WRX).
- Vollautomatisches Entriegeln und Wiederrüsten der Sicherheitseinrichtungen (ohne Handhebel).
- Oben angebrachtes Ölhydraulikaggregat, um im Arbeitsbereich Platz einzusparen.
- Lichtes Nutzmaß zwischen den Säulen von über 3 Metern.
- Struktur mit selbsttragender Säule für maximale Stabilität.
- **Heben durch 2 Hydraulikzylinder: Vollkommene Abwesenheit von Seilen, Ketten, Riemenscheiben oder anderen mechanischen Vorrichtungen, die einer konstanten Wartung bedürfen.**
- Einstellung der Gleichsetzung der beiden Schlit-ten über eine speicherprogrammierbare Steuerein-heit (SPS).

### ART. 199/WRX

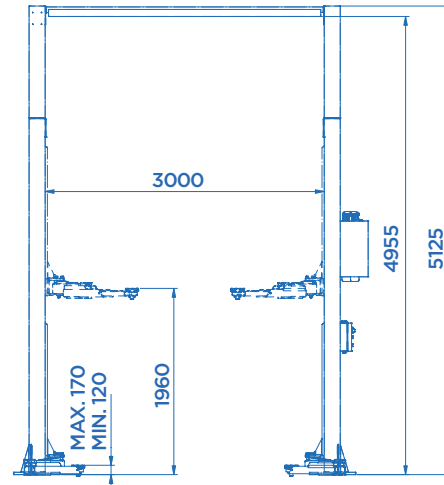
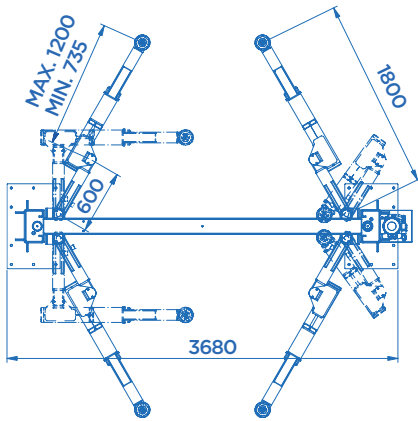

### ART. 199/WRL

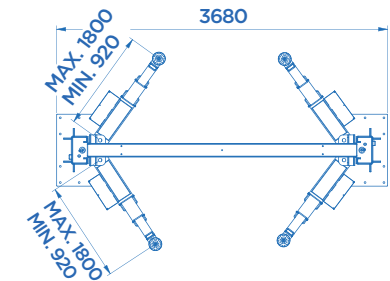
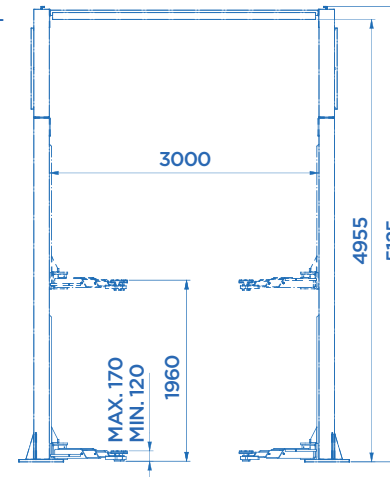

#### OPTIONAL Pag. 038



199/WRX



5500 Kg



2,2 KW

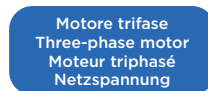

Motore trifase  
Three-phase motor  
Moteur triphasé  
Netzspannung

400V • 50HZ



1400

#### OPTIONAL Pag. 038



199/WRL



5500 Kg



2,2 KW

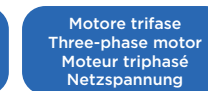

Motore trifase  
Three-phase motor  
Moteur triphasé  
Netzspannung

400V • 50HZ



1260

⚙️ Potenza motore • Motor power • Puissance moteur • Motorleistung

ART. 199/WL

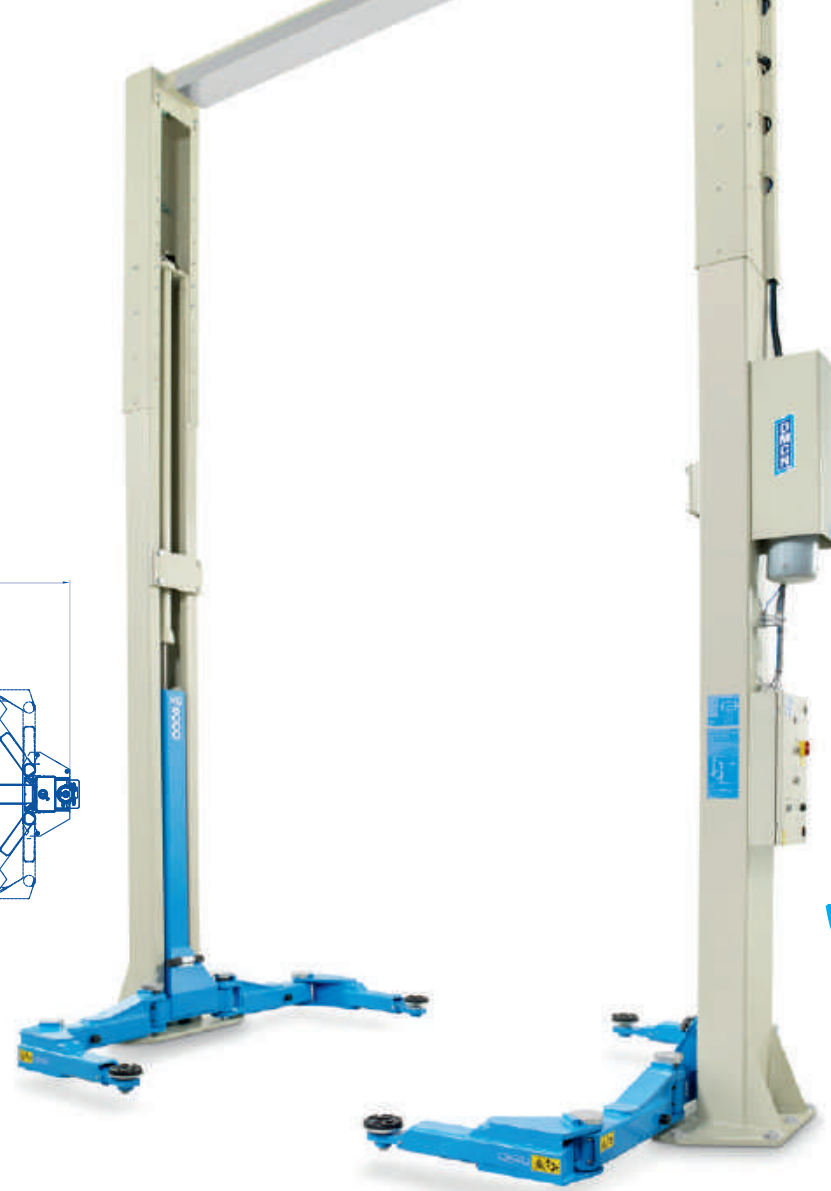
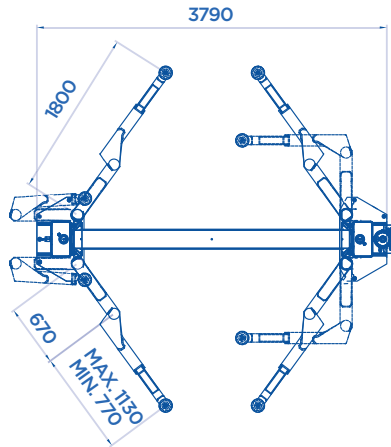
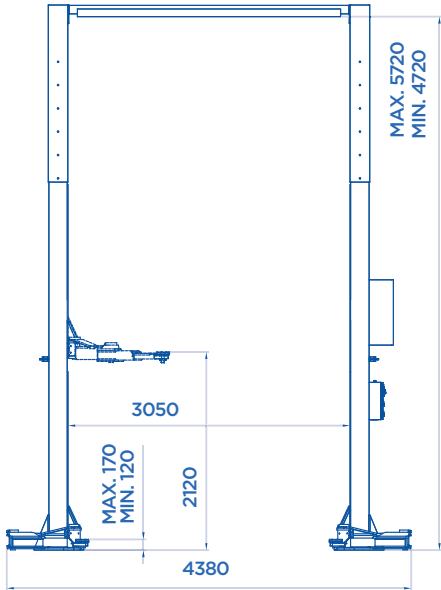

8000 **KG**

**HEAVY DUTY**

*All-in One*

**OPTIONAL** Pag. 038

<b>ART.</b>			Motore trifase Three-phase motor Moteur triphasé Netzspannung	
-------------	--	--	--	--

199/WL | 8000 Kg | 3,3 KW | 400V • 50HZ | 1850

Potenza motore • Motor power • Puissance moteur • Motorleistung



## ACCESSORI EXTRA DOTAZIONE

EXTRA EQUIPMENT • ACCESSOIRES EN OPTION • EXTRA ZUBEHÖR

**KIT** **X4**

**ART.**  mm **199/YL**  
**199/YP**

### ADATTATORI

Adaptors  
Adaptateurs  
Adapter

**370**  
**370/A**  
**370/B**  
**370/C**  
**370/D**

250  
380  
65  
45

✓  
✓  
✓  
✓  
✓



ART. 370



ART. 370/A



ART. 370/D

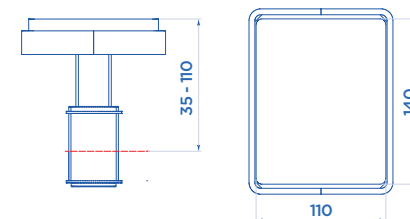

ART. 370/B



ART. 370/C



## ACCESSORI EXTRA DOTAZIONE

EXTRA EQUIPMENT • ACCESSOIRES EN OPTION • EXTRA ZUBEHÖR

### KIT

#### ADATTATORI

Adaptors  
Adaptateurs  
Adapter

#### ART.

A199/R  
B199/R  
C199/R  
D199/R  
E199/R  
G199/R  
H199/R

199/V • 199/W  
199/X  
199/WRX • 199/WRL  
199/WL



#### ART. G199/R

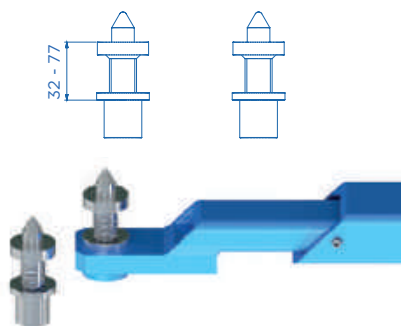

#### ART. H199/R

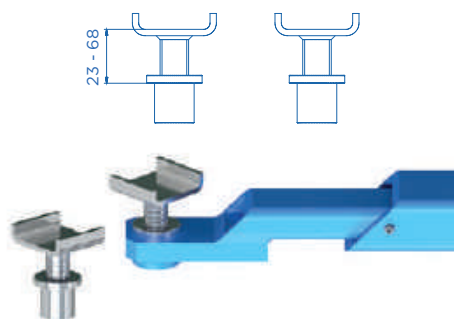

#### ART. D199/R

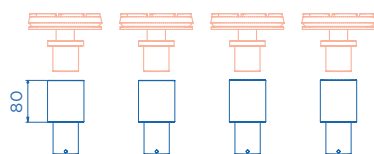

#### ART. E199/R

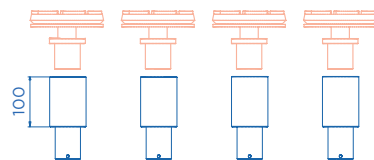

#### ART. A199/R

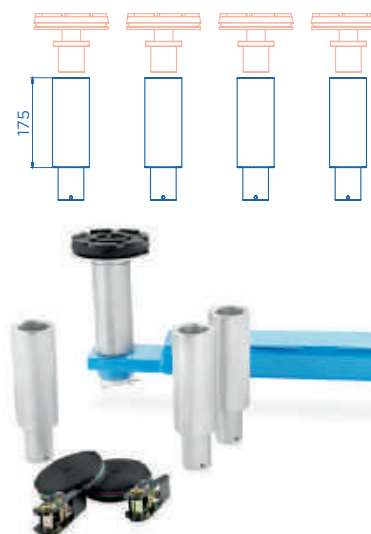

#### ART. B199/R



#### ART. C199/R

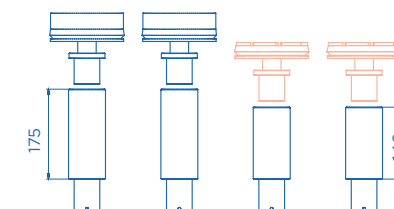



## TRACCIATO TECNICO COSTRUTTIVO

- Speciali forche per sollevare il veicolo dalle ruote ed avere il sottoscocca completamente libero.
- Indispensabili in caso di rimozione pacco batterie dal basso.
- Installazione estremamente facile: si rimuovono i tamponi forniti di serie con il sollevatore e si installano le forche.
- Utilizzo al bisogno senza necessità di acquistare un sollevatore dedicato.
- Forche dotate di rulli su cuscinetti per permettere la rotazione della ruota.

## TECHNICAL AND STRUCTURAL LAY-OUT

- Special forks to lift the vehicle from under the wheels and allow free access to the underbody.
- Mandatory to remove the battery group from below.
- Easy to install: just take the pads off and put the forks instead.
- Use it when you need it: no need to buy a new lift just for that use.
- The forks have rolls with bearings inside so that the wheel can roll freely.

## RELEVÉ TECHNIQUE

- Fourches spéciales pour soulever le véhicule par les roues afin de libérer complètement l'accès aux bas de caisse.
- Indispensable pour enlever le groupe batterie par le bas.
- Montage ultra facile : il suffit de retirer les tampons fournis avec le pont et de monter les fourches à leur place.
- Utilisez-les quand vous le souhaitez: nul besoin de faire l'achat d'un pont uniquement pour cet usage.
- Fourches dotées de rouleaux montés sur roulements pour que la roue tourne librement.

## TECHNISCHE UND KONSTRUKTIVE ANGABEN

- Spezielle Gabeln, um das Fahrzeug von den Rädern anzuheben und den Unterboden komplett frei zu haben.
- Unverzichtbar bei der Entnahme des Akkupacks von unten.
- Unkomplizierte Installation: Einfach die vormontierten Doppelhubpuffer entfernen und die Gabeln anbringen.
- Verwendung nach Bedarf, ohne dass eine extra Bühne gekauft werden muss.
- Gabeln mit gelagerten Rollen, die die Drehung des Rades ermöglichen.

## ART. N199/RX

ART. **N199/RX** | 1000 Kg X 4

MAX

199/WRX  
199/WL

✓

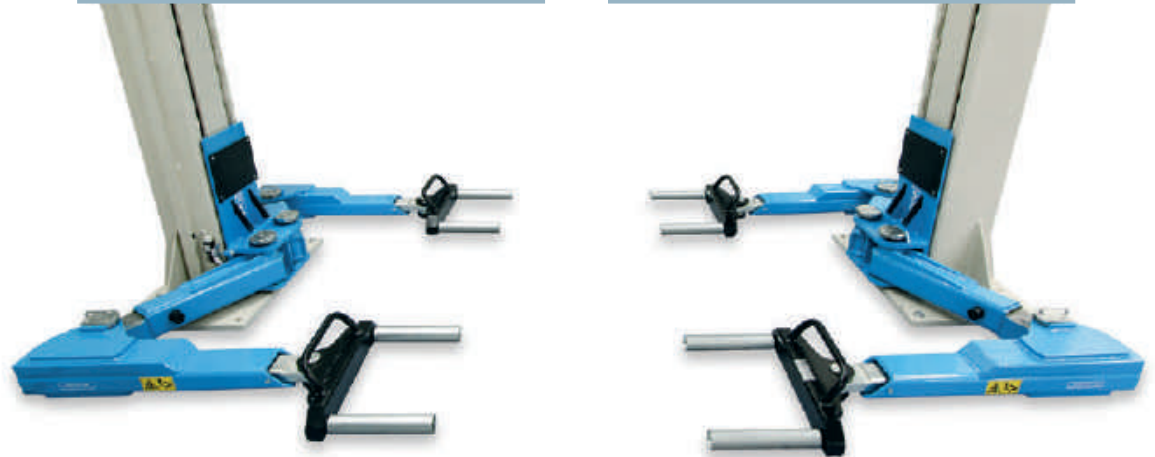
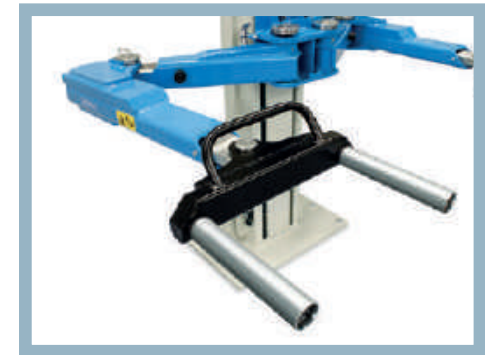
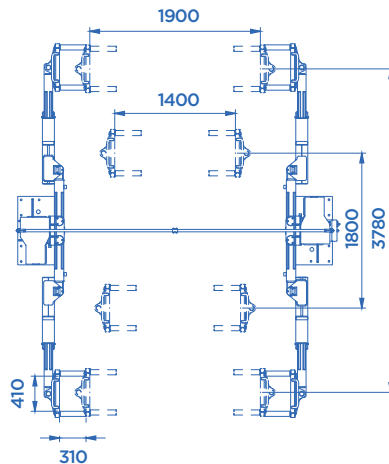
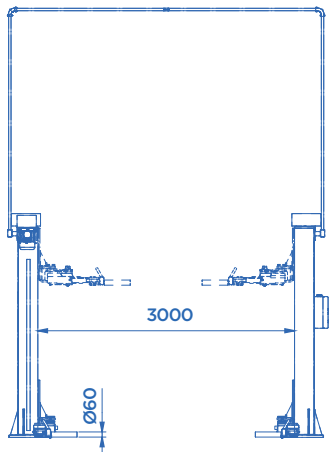

## ACCESSORI EXTRA DOTAZIONE

EXTRA EQUIPMENT • ACCESSOIRES EN OPTION • EXTRA ZUBEHÖR

### ART. 371 DUE COPPIE DI CAVALLETTI PER ASSETTO RUOTE PER PONTE SOLLEVATORE A DUE COLONNE

Two pairs of wheel alignment stands for two post lifts  
Deux paires de chevalets pour la géométrie des roues sur pont 2 colonnes  
2 Paar fahrbare Unterstellböcke zur Achsvermessung für 2-Säulen Hebebühnen



### ART. 373 SET DI PROLUNGHE

Pair of extensions  
Paire de rallonges  
2 Verlängerungen

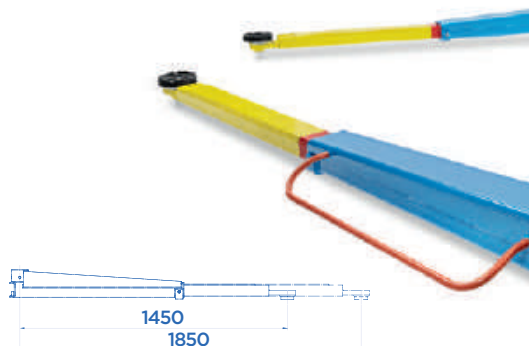

ART.

373



600 Kg X 2

199/V  
199/W  
199/X



### ART. 372 TAMPONE A REGOLAZIONE RAPIDA



Fast adjustable pad  
Tampon à réglage rapide  
Pufferhalterung mit  
Schnelleinstellung

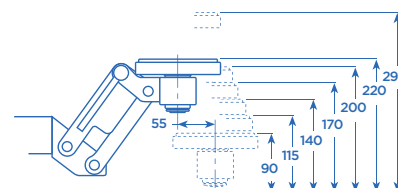
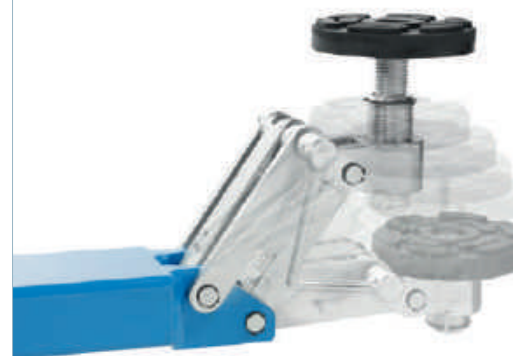

✓ ART. 199/YL • 199/YP

- Diverse posizioni stabili ad aggancio automatico.
- Tampone regolabile a vite a doppia sfilata.
- Una facilità di utilizzo, regolazione e posizionamento.

- Different stable positions for automatic coupling.
- Double stage screw adjustable pads.
- Easy to use, adjust and position.

- Différentes positions stables à accrochage automatique.
- Tampon réglable à vis à double étage.
- La facilité d'utilisation, de réglage, et de positionnement.

- Verschiedene feste Positionen mit automatischer Aufnahme.
- Puffer mit Schraubeinstellung und mit doppeltem Lauf.
- Die Einfachheit im Gebrauch, der Einstellung und Positionierung.

### NOTE

---

---

---

---

---

---

---

---

---

---

---

---

---

---

---

---

---

---

---

---

---

---

---

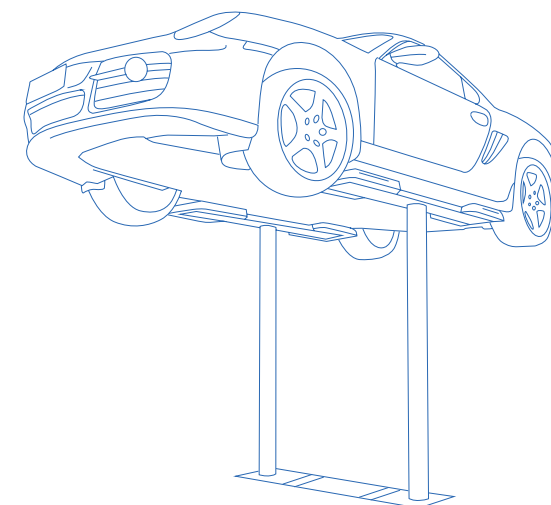

**PONTI SOLLEVATORI ELETTROIDRAULICI  
A CILINDRI INTERRATI**

HYDRAULIC 2-RAM INGROUND LIFTS  
PONTS ELEVATEURS ENCASTRES A VERINS HYDRAULIQUES  
HYDRAULISCHE 2-ZYLINDER UNTERFLUR STEMPEL-BÜHNEN

Made in Italy 



## PONTI SOLLEVATORI ELETTROIDRAULICI A CILINDRI INTERRATI

### HYDRAULIC 2-RAM INGROUND LIFTS

#### TRACCIATO TECNICO COSTRUTTIVO

- Comandi di funzionamento ad azione mantenuta.
- Circuito di comando e sicurezze elettriche in bassa tensione 24 V.
- Dispositivo acustico e comando a due mani nell'ultima fase di discesa.
- Connessione meccanica per la sincronizzazione dei cilindri, garanzia di livellamento pedane indipendentemente dalla ripartizione del carico.
- Valvole di sicurezza per controllo velocità di discesa e sovraccarico.
- **Valvole pneumatiche che permettono la discesa in emergenza.**
- Protezione contro le perdite di fluido garantita da valvole di non ritorno.
- Garanzia di rapido posizionamento del veicolo sul sollevatore grazie alla minima altezza da terra di 65 mm. (Art. 2002).
- Pedane a lunghezza regolabile dotate di dispositivo di bloccaggio (Art. 2002).
- Pedane a larghezza regolabile garanzia di presa di veicoli a diversa carreggiata (Art. 2002).
- Bracci di sollevamento dotati di tamponi regolabili in altezza (Art. 2005).
- Aumento della sicurezza sul posto di lavoro grazie al minimo ingombro del sollevatore.
- **Completi di cassaforma per incasso elettrosaldata, rinforzata e a tenuta stagna.**

#### TECHNICAL AND STRUCTURAL LAY-OUT

- "Man standing-by" controls.
- Electrical control system and safeties in low tension 24 V.
- Sound device and two hand control during the last descent phase.
- Mechanical connection for the synchronization of the cylinders, assured levelling of the footboards whatever the distribution of the weight is.
- Safety valves for the descent speed control and for the overload.
- **Pneumatic valves which allow the emergency descent.**
- Protection against the fluid leak assured by nonreturn valves.
- A sure fast placement of the vehicle on the lift thanks to the minimum height from the floor of 65 mm. (Art. 2002).
- Length adjustable footboards equipped with locking device (Art. 2002).
- Width adjustable footboards which assure the lifting of vehicles of different width (Art. 2002).
- Lifting arms c/w height-adjustment rubber pads (Art. 2005).
- Increase of the safety on the working place thanks to the minimum volume of the lift.
- **Equipped with electrowelded, reinforced and watertight formwork.**



# PONTS ELEVATEURS ENCASTRES A VERINS HYDRAULIQUES

## HYDRAULISCHE 2-ZYLINDER UNTERFLUR STEMPEL-BÜHNEN

### RELEVÉ TECHNIQUE

- Commande de type "homme mort".
- Circuit de commande et dispositifs électriques de sécurité en basse tension 24 V.
- Dispositif sonore et commande à deux mains dans la dernière phase de descente.
- Connexion mécanique pour la synchronisation des vérins: synchronisation garantie indépendamment de la répartition de charge.
- Soupape de sécurité pour contrôle vitesse de descente et surcharge.
- **Vannes pneumatiques pour permettre la descente en urgence.**
- Protection contre les pertes de fluide par soupape anti-retour.
- Positionnement rapide du véhicule sur l'élevateur grâce à une hauteur de terre de 65 mm. (Art. 2002).
- Chemins de roulement à longueur réglable avec dispositif de blocage (Art. 2002).
- Chemins de roulement à largeur réglable pour le levage de différents empattements de véhicules.
- Bras de levage avec tampons réglables en hauteur (Art. 2005).
- Plus grande sécurité sur le lieu de travail grâce à un encombrement minimum.
- **Avec caisson électro-soudé, étanche et renforcé.**

### TECHNISCHE UND KONSTRUKTIVE ANGABEN

- Totmann-Steuerung.
- Elektrische Systemsteuerung und Sicherheitsvorrichtung bei niedrigen 24 V.
- Akustisches Warnsignal und 2-Hand-Steuerung, während der letzten Absenk-Phase.
- Mechanische Verbindung für die Synchronisierung der Zylinder, sicheres synchronisieren der Aufnahmeschienen, unabhängig von der Verteilung des Gewichts.
- Sicherheitsventile für die Absenk-Geschwindigkeit und für Überladung.
- **Pneumatische Ventile für Notablass.**
- Schutz vor Flüssigkeitsaustritt auf Grund von Rückschlagventilen.
- Ein sicheres und schnelles Platzieren von Fahrzeugen auf der Bühne dank geringer Bauhöhe von 65 mm. (Art. 2002).
- In Längsrichtung einstellbare Aufnahmeschiene ausgestattet mit Feststellvorrichtung (Art. 2002).
- In breite einstellbare Aufnahmeschienen, welche das Heben von Fahrzeugen von unterschiedlichen Breiten ermöglicht (Art. 2002).
- Hebearme mit höhenverstellbare Gummiauflagen (Art. 2005).
- Verbesserung der Arbeitsplatz-Sicherheit wegen der geringen Größe der Hebebühne.
- **Mit verstärktem, wasserdichtem und elektro-verschweißstem Rahmen für versenkbare Ausführung.**



**ART. 2002**  
**SOLLEVATORE ELETTROIDRAULICO A CILINDRI**  
**INTERRATI DOTATO DI PEDANE REGOLABILI IN**  
**LUNGHEZZA A CARREGGIATA VARIABILE**

Electrohydraulic 2-ram inground lift equipped with adjustable footboards both in length and in width

Elévateur encastré à 2 vérins électrohydraulique doté de chemins de roulements réglables en longueur et sur différents empattements

Elektrohydraulische Unterflur Stempelbühne mit in Länge-und Breite verschiebbaren Aufnahmeschienen



<b>ART.</b>			Motore trifase Three-phase motor Moteur triphasé Netzspannung	
-------------	---	---	--	---

**2002** | 3500 Kg | 3 KW | 400V • 50HZ | 1130

 Potenza motore • Motor power • Puissance moteur • Motorleistung

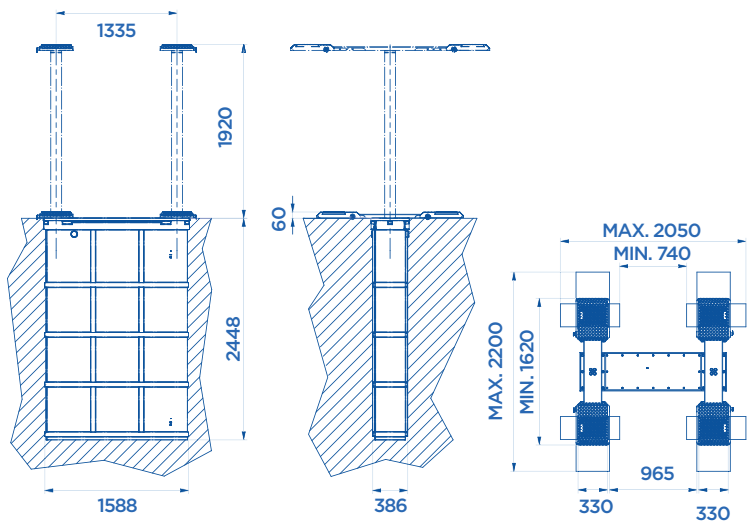



**ART. 2005 • 2005/L**  
**SOLLEVATORE ELETTRIDRAULICO**  
**A CILINDRI INTERRATI DOTATO**  
**DI BRACCI REGOLABILI**

Electrohydraulic 2-ram inground lift equipped with adjustable arms

Elévateur encastré à 2 vérins électrohydraulique à bras réglables

Elektrohydraulische Unterflur Stempelbühne mit 4-2-Fach Teleskop-Hebearmen

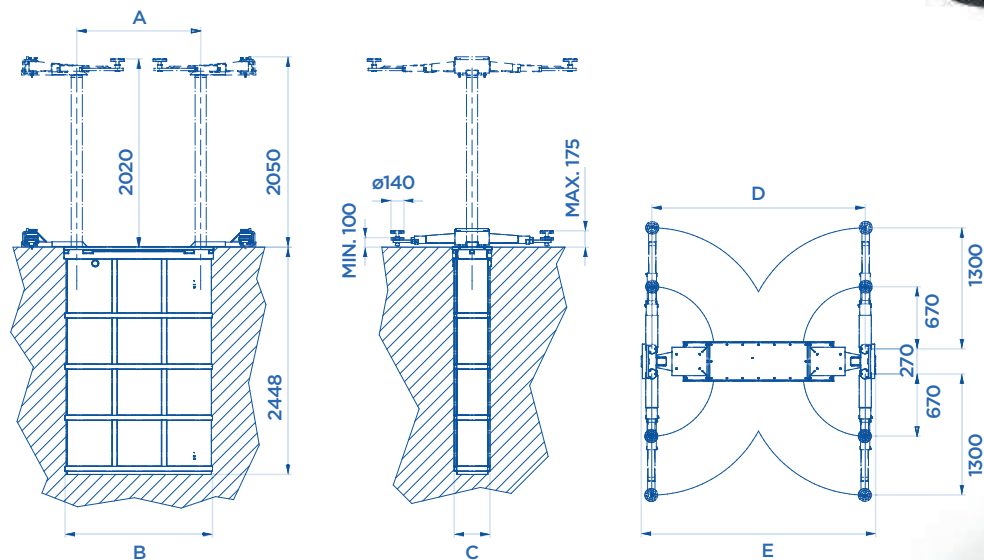

ART.			Motore trifase Three-phase motor Moteur triphasé Netzspannung	A	B	C	D	E	
				mm	mm	mm	mm	mm	KG
2005	3500 Kg	3 KW	400V • 50HZ	1335	1588	386	2300	2525	1140
2005/L	3500 Kg	3 KW	400V • 50HZ	2285	2538	386	2600	2825	1300

Potenza motore • Motor power • Puissance moteur • Motorleistung





NOTE

---



---



---



---



---



---



---



---



---



---



---



---



---



---



---



---



---



---



---



---



---



---



---



---

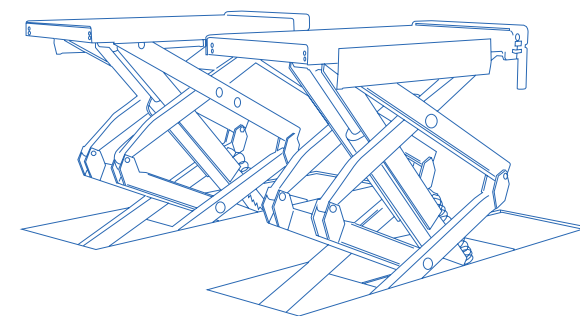

**PONTI SOLLEVATORI  
ELETTRIDRAULICI A DOPPIA FORBICE**

ELECTROHYDRAULIC TWIN-SCISSOR LIFTS  
PONTIS ELEVATEURS A DOUBLE CISEAUX ELECTROHYDRAULIQUES  
ELEKTROHYDRAULISCHE DOPPEL-SCHEREN-HEBEBÜHNEN

Made in Italy 

## PONTI SOLLEVATORI ELETTROIDRAULICI A DOPPIA FORBICE

### ELECTROHYDRAULIC TWIN-SCISSOR LIFTS



#### TRACCIATO TECNICO COSTRUTTIVO

- Comandi "uomo presente" - Tensione ausiliaria 24 V.
- Sicurezze meccaniche di stazionamento e paracadute su ognuno dei due pistoni.
- Parallelismo idraulico ed allineamento sincrono delle pedane indipendentemente dalla ripartizione del carico.
- Valvole di sicurezza per il controllo velocità di discesa, del sovraccarico e delle rotture accidentali tubi di alimentazione.
- Pedane a lunghezza regolabile per un corretto stazionamento di ogni tipo di vettura.
- Valvola manuale di discesa in caso di assenza di energia elettrica.
- Dispositivo acustico e comando a due mani nell'ultima fase di discesa.
- Perna con boccole di bronzo autolubrificanti.
- Nella posizione di completo rientro, il pavimento risulta completamente libero.
- Nessuna sporgenza in posizione rientrata.
- Dispositivo automatico con elettrovalvole per allineamento delle pedane.
- **Pompa manuale per sblocco sicurezze e valvola d'apertura, sempre manuale, per la discesa del sollevatore in caso di assenza di energia elettrica** (Art. 705 - 705/M).
- Olio per circuito idraulico in dotazione.
- Tasselli di ancoraggio al suolo in dotazione.

#### TECHNICAL AND STRUCTURAL LAY-OUT

- "man standing-by" controls - Auxiliary tension 24 V.
- Mechanical standing safeties and a parachute on both pistons.
- Hydraulic parallelism and synchronized alignment of the platforms independently from the load distribution.
- Safety-valves to check descent speed, overload and accidental breakage of feeding pipes.
- Adjustable length platforms for a correct standing of any kind of vehicle.
- Manual descent valve in case of power failure.
- Sound device and two hand control during the last descent phase.
- Self-lubricating pins in bronze bushes.
- In total re-entry position, the floor looks completely free.
- No protrusion in the re-entry position.
- Automatic device with electro-valve for the platforms alignment.
- **Manual pump for the release of the safeties and of the opening-valve, still manual, for the descent of the hoist in case of electric energy lack** (Art. 705 - 705/M).
- Delivered with oil for the hydraulic circuit.
- Equipped with anchor small blocks.

# PONTS ELEVATEURS A DOUBLE CISEAUX ELECTROHYDRAULIQUES

## ELEKTROHYDRAULISCHE DOPPEL-SCHEREN-HEBEBÜHNEN

### RELEVÉ TECHNIQUE

- Commande de type "homme mort" Tension auxiliaire 24 V.
- Sécurité mécanique à chaque stade de levage, et parachute sur chaque piston.
- Parallélisme hydraulique et alignement synchronisé des plateformes de levage indépendamment de la répartition de charges.
- Soupapes de sécurité pour le contrôle de la vitesse de descente, de surcharge et de rupture accidentelle des tuyaux d'alimentation.
- Plateformes de levage à longueur réglable pour chaque type de voiture.
- Vanne manuelle de descente, en cas de coupure de courant.
- Dispositif sonore et commande à deux mains dans la dernière phase de descente.
- Bagues en bronze autolubrifiantes.
- En position repliée, ce modèle permet de disposer d'une surface au sol entièrement dégagée, libre de tout obstacle.
- En position repliée, le sol est complètement dégagé.
- Dispositif automatique avec électrovanne pour alignement des chemins de roulement.
- **Pompe manuelle pour débloquer les sécurités et valve d'ouverture, toujours manuelle, pour la descente de l'élevateur en cas de coupure de courant** (Art. 705 - 705/M).
- Livrés avec l'huile pour le circuit hydraulique.
- Chevilles d'ancrage au sol fournies.

### TECHNISCHE UND KONSTRUKTIVE ANGABEN

- "Stand-by Steuerung". Steuerspannung 24 V.
- Mechanische Stützvorrichtung und Absenkschutz an beiden Kolben.
- Perfekte hydraulische Gleichlaufregelung, d.h. synchronisierte (aufeinander abgestimmte) Ausrichtung der Fahrschienen unabhängig von der Lastverteilung.
- Sicherheitsventile zur Kontrolle der Absenkgeschwindigkeit, als Überlastungsschutz und zur Überwachung der Druckleitungen.
- In der Länge justierbare Fahrschienen sorgen für einen sicheren und festen Stand eines jeden Fahrzeugtyps.
- Manuelles Absenken im Falle eines Stromausfalls möglich.
- Akustisches Signal und 2-Hand-Steuerung während der letzten Absenkphase.
- Selbstschmierende Bolzen in Bronze-Buchsen.
- In komplett abgesenktem Zustand ist der Werkstattraum - dank des Fehlens von Vorsprüngen - vollständig frei.
- Automatische Steuerung des Fahrschienen-gleichlaufs mit Elektroventil.
- **Im Falle eines Stromausfalls kann die Bühne von Hand mittels einer Pumpe, die die Sicherheitsvorkehrungen und das Öffnungsventil entriegelt, abgelassen werden** (Art. 705 - 705/M).
- Wird mit Öl für die hydraulische Schaltung geliefert.
- Ausgestattet mit schmaler Grundplatte.

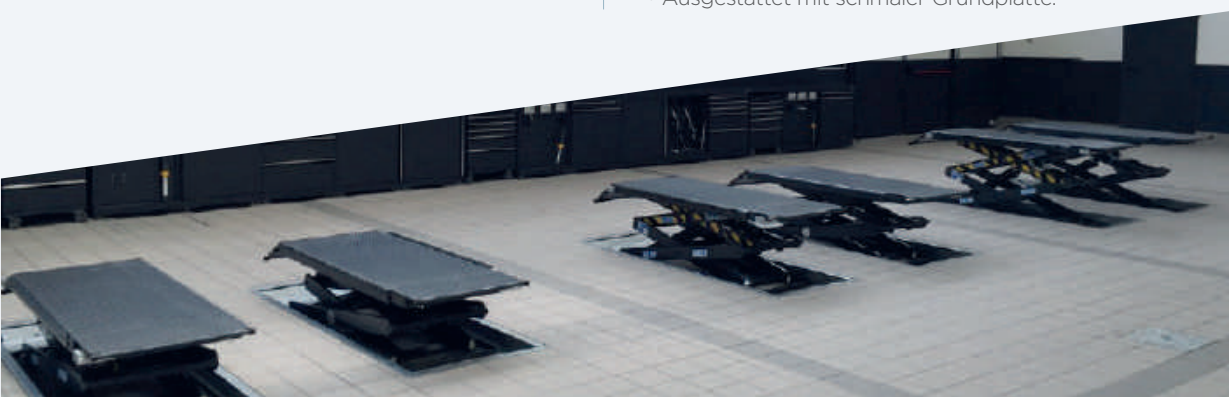

OMCN



3000  
3500 **KG**



ART. 705



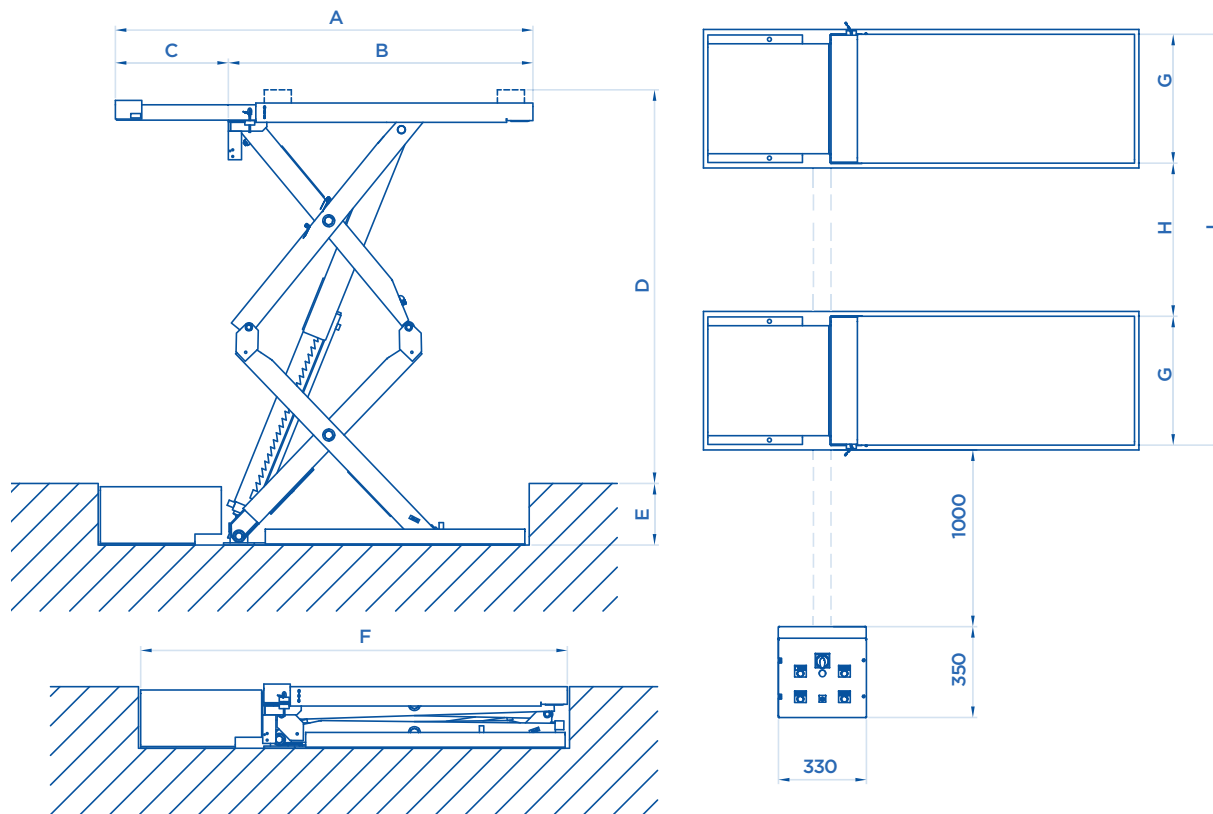

**OPTIONAL** Pag. 064

ART.			Motore trifase Three-phase motor Moteur triphasé Netzspannung	A	B	C	D	E	F	G	H	I	
				mm	mm	mm	mm	mm	mm	mm	mm	mm	KG
<b>703</b>	3000 Kg	3,3 KW	400V • 50HZ	1755	1385	370	1800	270	1785	520	800	1840	910
<b>703/A</b>	3000 Kg	3,3 KW	400V • 50HZ	1900	1385	515	1800	270	1955	520	800	1840	950
<b>705</b>	3500 Kg	3,3 KW	400V • 50HZ	1900	1385	515	1800	280	1955	590	800	1980	1000
<b>705/M</b>	3500 Kg	3,3 KW	400V • 50HZ	2100	1585	515	1800	280	2155	590	800	1980	1050

Potenza motore • Motor power  
Puisissance moteur • Motorleistung



4000 **KG**

**HEAVY  
DUTY**

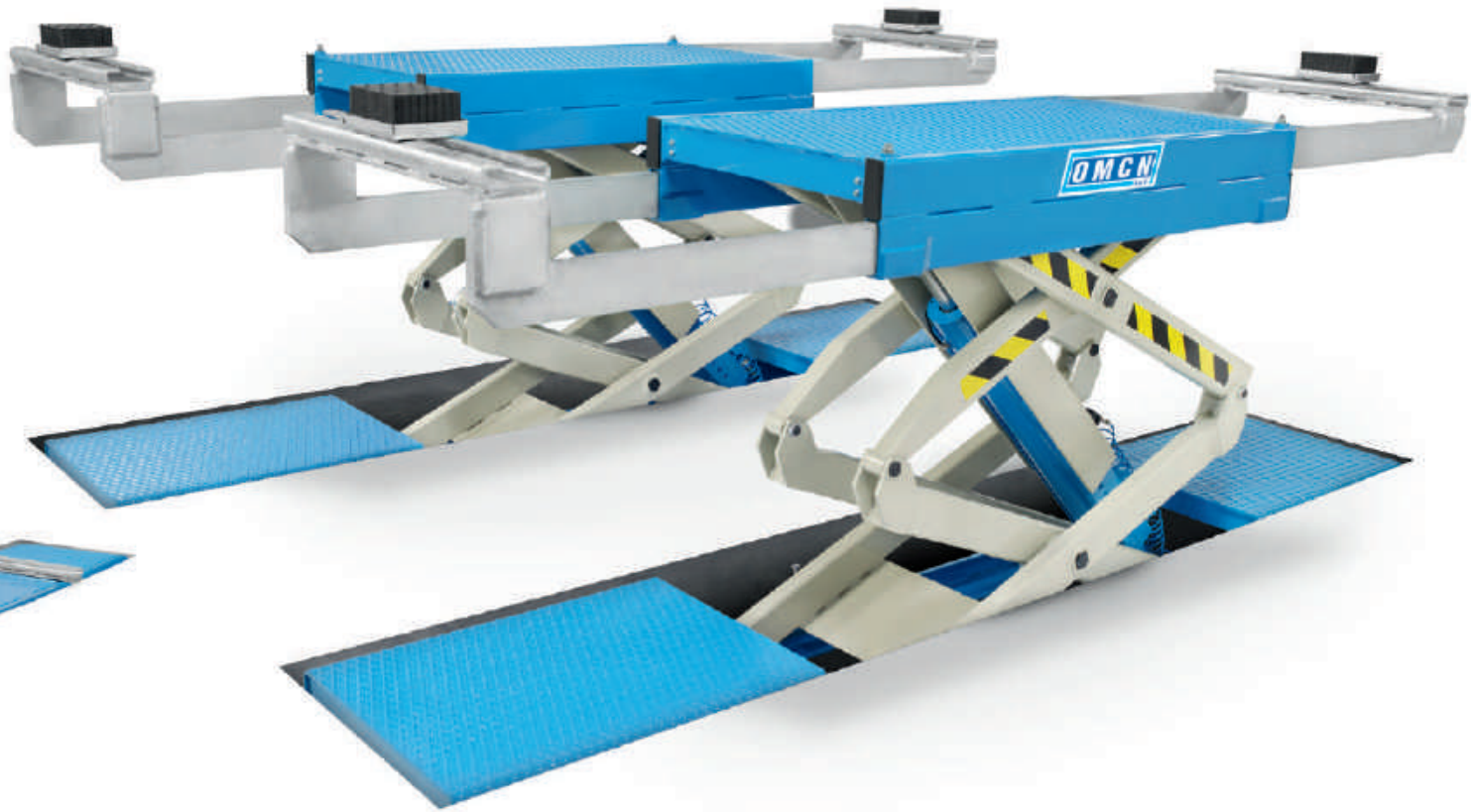

ART. 730



## TRACCIATO TECNICO COSTRUTTIVO

- Sicurezze meccaniche di stazionamento e paracadute su ognuno dei due pistoni.
- Valvole di sicurezza per il controllo velocità di discesa, del sovraccarico e delle rotture accidentali tubi di alimentazione.
- **Dotato di doppie prolunghe anteriori e posteriori per poter sollevare sia piccole vetture che veicoli commerciali a passo lungo.**
- Perni con boccole di bronzo autolubrificanti.
- Dispositivo automatico con elettrovalvole per allineamento delle pedane.
- Pompa manuale per sblocco sicurezze e valvola d'apertura, sempre manuale, per la discesa del sollevatore in caso di assenza di energia elettrica.

## TECHNICAL AND STRUCTURAL LAY-OUT

- Mechanical standing safeties and a parachute on both pistons.
- Safety-valves to check descent speed, overload and accidental breakage of feeding pipes.
- **Equipped with front and rear extensions in order to lift both small cars and long commercial vehicles.**
- Self-lubricating pins in bronze bushes.
- Automatic device with electro-valve for the platforms alignment.
- Manual pump for the release of the safeties and of the opening-valve, still manual, for the descent of the hoist in case of electric energy lack.

## RELEVÉ TECHNIQUE

- Sécurité mécanique à chaque stade de levage, et parachute sur chaque piston.
- Soupapes de sécurité pour le contrôle de la vitesse de descente, de surcharge et de rupture accidentelle des tuyaux d'alimentation.
- **Rallonges antérieures et postérieures capables de soulever de la petite utilitaire au fourgon extra-long.**
- Bagues en bronze autolubrifiantes.
- Dispositif automatique avec électrovanne pour l'alignement des chemins de roulement.
- Pompe manuelle pour débloquer les sécurités et valve d'ouverture, toujours manuelle, pour la descente de l'élevateur en cas de coupure de courant.

## TECHNISCHE UND KONSTRUKTIVE ANGABEN

- Mechanische Stützvorrichtung und Absenkschutz an beiden Kolben.
- Sicherheitsventile zur Kontrolle der Absenkgeschwindigkeit, als Überlastungsschutz, und zur Überwachung der Druckleitungen.
- **Mit Doppel-Verlängerungen (vornhinten), welche das Heben von kleinen PKW bis zu langen Lieferwagen ermöglicht.**
- Selbstschmierende Bolzen in Bronze-Buchsen.
- Automatische Steuerung des Fahr schienengleichlaufs mit Elektroventil.
- Im Falle eines Stromausfalls kann die Bühne von Hand mittels einer Pumpe, die die Sicherheitsvorkehrungen und das Öffnungsventil entriegelt, abgelassen werden.

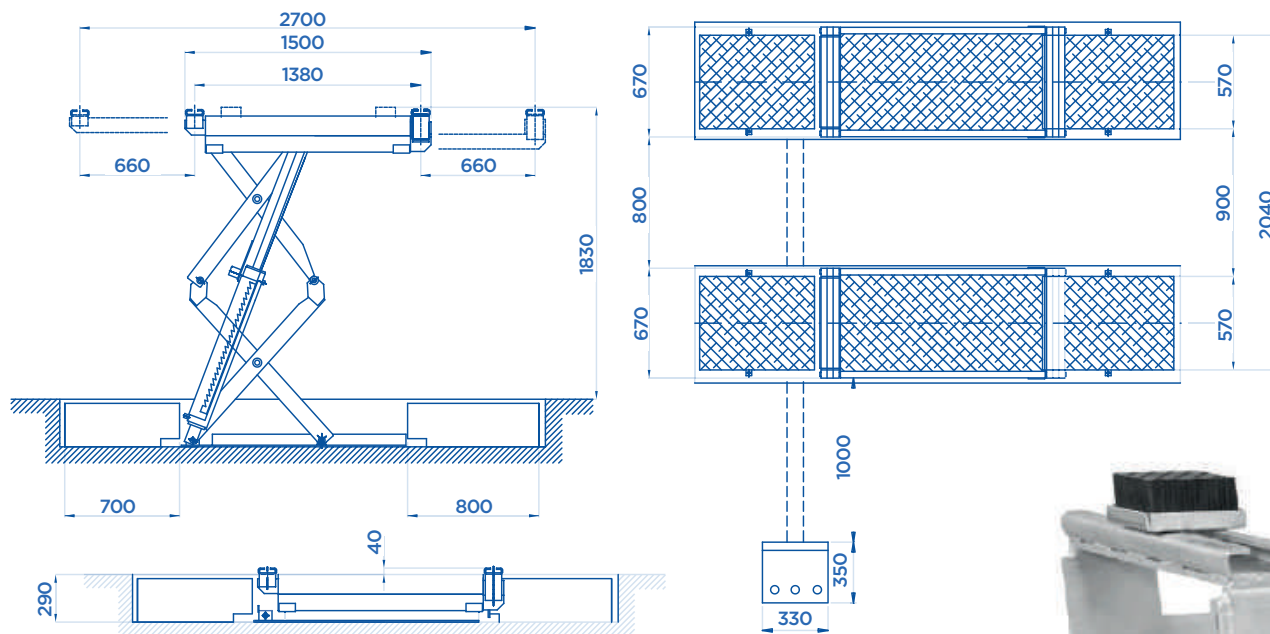

### OPTIONAL Pag. 064

ART.

730



4000 Kg



3,3 KW

Motore trifase  
Three-phase motor  
Moteur triphasé  
Netzspannung

400V • 50HZ



1200



Potenza motore • Motor power • Puissance moteur • Motorleistung

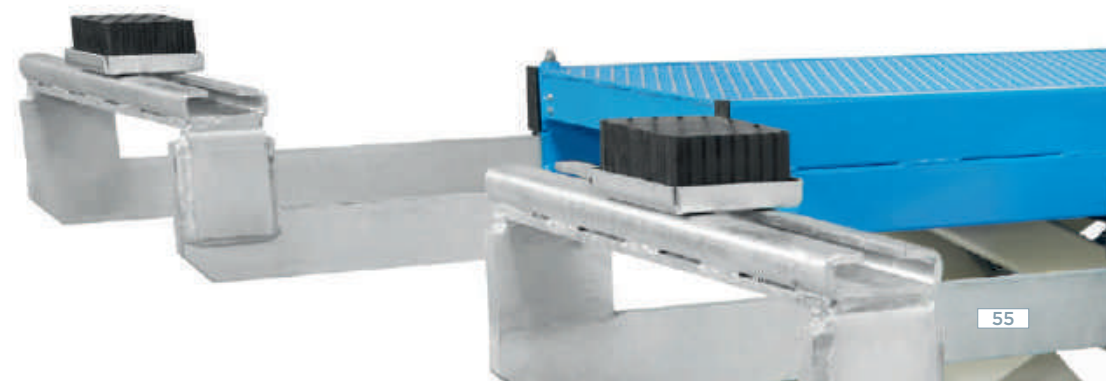





ART. 718 • 719

3500 **KG**



ART. 718



## TRACCIATO TECNICO COSTRUTTIVO

- Sollevatori elettroidraulici a basso profilo; particolarmente indicati per il sollevamento di veicoli con carrozzeria ribassata senza necessità di realizzare le buche per l'incasso.
- Le doppie prolunghe sulla pedana permettono un rapido ed agevole posizionamento del veicolo.
- Pedane sincronizzate idraulicamente con dispositivo di controllo del livellamento.
- **Due pistoni per ogni pedana.**
- **Collegamento dell'aria non necessario.**
- Perni con boccole di bronzo autolubrificanti.
- Comandi a bassa tensione del tipo "uomo presente".
- Valvole di sicurezza e di blocco sul circuito idraulico, per il controllo della pressione e contro la rottura dei tubi.
- Velocità di discesa controllata con compensazione idraulica.
- Dispositivo acustico e comando a due mani nell'ultima fase di discesa.
- Olio per circuito idraulico in dotazione.
- Tasselli di ancoraggio al suolo in dotazione.

## TECHNICAL AND STRUCTURAL LAY-OUT

- Low profile electrohydraulic hoists; particularly indicated to lift vehicles with lowered body without the need to make holes for the disappearing.
- The twin extensions on the platform allow a quick and easy positioning of the vehicle.
- Hydraulically synchronized platforms with levelling control device.
- **Two pistons for each platform.**
- **Air connection not required.**
- Self-lubricating pins in bronze bushes.
- "Man standing-by" low tension controls.
- Safety and lock valves on the hydraulic circuit for the check of the pressure and the pipes break.
- Controlled lowering speed with hydraulic compensation.
- Sound device and two hand control during the last descent phase.
- Delivered with oil for the hydraulic circuit.
- Equipped with anchor small blocks.

## RELEVÉ TECHNIQUE

- Ponts électro-hydrauliques surbaissés; particulièrement indiqués pour le levage de véhicules à bas de caisse extra bas. Evite d'en passer par le génie civil pour les fosses d'encastrement.
- Les doubles rallonges sur le chemin de roulement facilitent le positionnement du véhicule.
- Synchronisation hydraulique des chemins de roulement avec mise à niveau constante.
- **Deux verins pour chaque chemin de roulement.**
- **Connection de l'air inutile.**
- Bagues en bronze autolubrifiantes.
- Commandes basse tension de type "homme mort".
- Circuit hydraulique muni de soupape d'arrêt de sécurité pour contrôler la pression et éviter toute rupture de tuyau.
- Contrôle de la vitesse de descente par compensation hydraulique.
- Dispositif sonore et commande à deux mains dans la dernière phase de descente.
- Livrés avec l'huile pour le circuit hydraulique.
- Chevilles d'ancrage au sol fournies.

## TECHNISCHE UND KONSTRUKTIVE ANGABEN

- Elektrohydraulische Hebebühnen mit flachem Profil; speziell geeignet, um Fahrzeuge mit tiefergelegter Karosserie anzuheben, ohne die Notwendigkeit von Aufnahmeöffnungen.
- Die doppelten Verlängerungen der Fahrschienen ermöglichen eine schnelle und leichte Positionierung des Fahrzeuges.
- Hydraulische Synchronisierung der Fahrschienen mit Nivellierungsüberwachungsrichtung.
- **2 Kolben für jede Fahrschiene.**
- **Luftanschluß ist nicht erforderlich.**
- Selbstschmierende Bolzen in Bronze-Buchsen.
- Niederspannungs "Stand by-Steuerung".
- Sicherheits- und Überdruckventile zur Überwachung der Hydraulikleitung.
- Überwachung der Absenkgeschwindigkeit durch Hydraulikausgleich.
- Akustisches Signal und 2-Hand-Steuerung während der letzten Absenkphase.
- Wird mit Öl für die hydraulische Schaltung geliefert.
- Ausgestattet mit schmaler Grundplatte.

### ART. 718

Modello a pavimento  
Floored model  
Modèle au sol  
Überflur-Modell

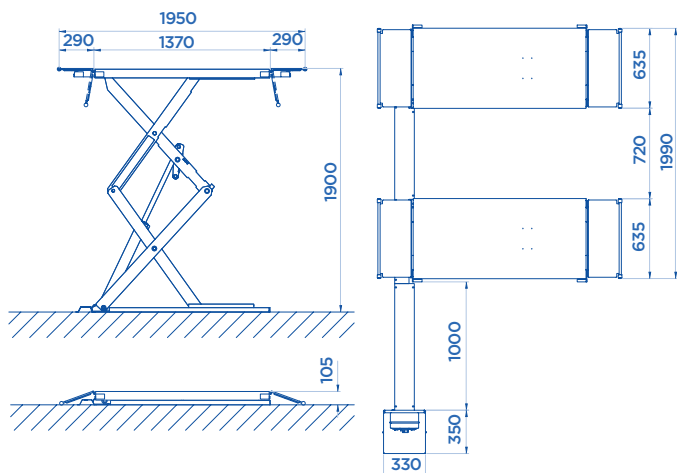

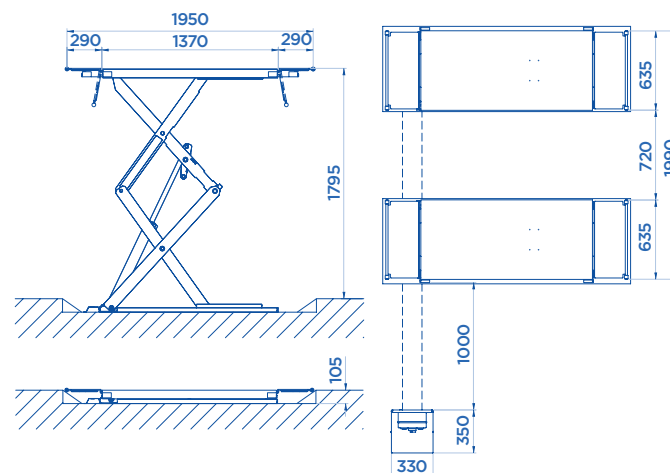

### ART. 719

Modello a scomparsa  
Disappearing model  
Modèle encastrable  
Unterflur-Modell



OPTIONAL Pag. 064

ART.			Motore trifase Three-phase motor Moteur triphasé Netzspannung	
718	3500 Kg	3,3 KW	400V • 50HZ	930
719	3500 Kg	3,3 KW	400V • 50HZ	930

 Potenza motore • Motor power • Puissance moteur • Motorleistung



ART. 718/M • 719/M

3500 **KG**

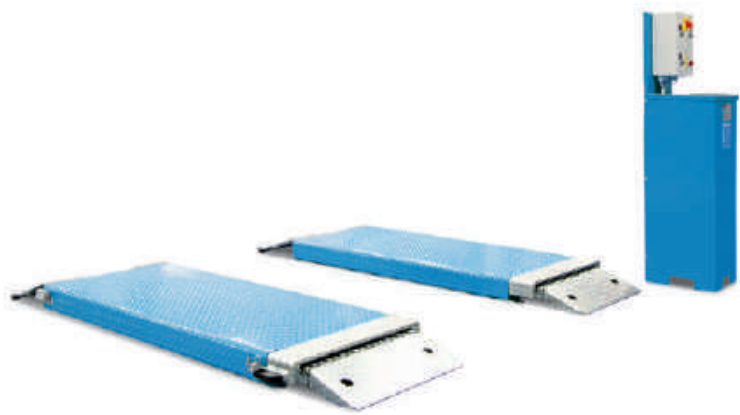

ART. 718/M

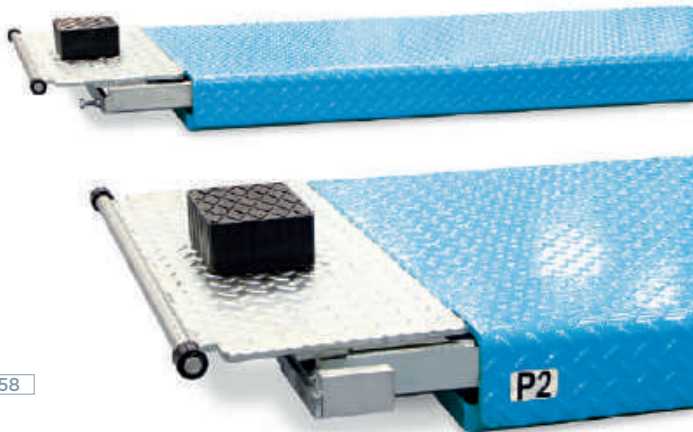

**L. MAX 2300**  
mm.

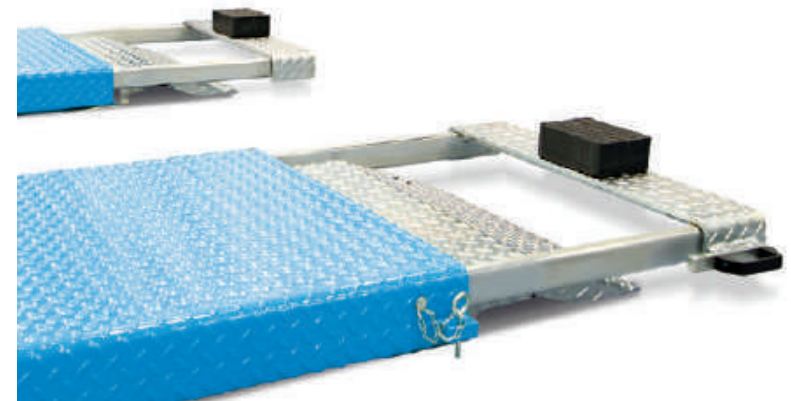

## TRACCIATO TECNICO COSTRUTTIVO

- Esclusivo circuito idraulico a quattro pistoni.
- **Premendo il pulsante discesa il sollevatore scende in presa diretta con regolazione millimetrica, peculiarità importante per operazioni di precisione quali la rimozione di componenti pesanti dal veicolo.**
- Prolunghe pedana a sfilata per garantire quote di lunghezza minima e massima che permettano il sollevamento di un'ampia gamma di veicoli.
- Perna con boccole in bronzo autolubrificanti.
- **Non necessita di collegamento dell'aria compressa.**
- Pedane sincronizzate idraulicamente con dispositivo di controllo del livellamento.
- Velocità di discesa controllata mediante compensazione idraulica.
- Valvole di sicurezza e di blocco sul circuito idraulico, per il controllo della pressione e contro la rottura dei tubi.
- Olio per circuito idraulico in dotazione.
- Tasselli di ancoraggio al suolo in dotazione

## TECHNICAL AND STRUCTURAL LAY-OUT

- Exclusive 4-pistons hydraulic circuit.
- **Lift immediately starts lowering with millimetric precision when lowering pushbutton is activated, to allow the user remove heavy components of the vehicle with extreme precision.**
- Pull out footboard extensions to grant min-max length useful to lift a wide range of vehicles.
- Pins with self-lubricant bronze bushes.
- **Connection to compressed air not necessary.**
- Footboards hydraulically synchronized by levelling control device.
- Hydraulic compensation to control lowering speed.
- Safety and check valves on the hydraulic circuit to keep pressure under control and against pipes breakage.
- Oil for hydraulic circuit supplied as a standard.
- Anchor bolts supplied as a standard.

## RELEVÉ TECHNIQUE

- Circuit hydraulique exclusif à 4 vérins
- **L'ajustement de la prise du pont se fait au millimètre près par simple actionnement du bouton de descente: spécificité importante pour les travaux de précision, quand vous devez retirer une pièce lourde d'un véhicule par exemple.**
- Doté d'une rallonge qui élargit encore la gamme des véhicules possibles à soulever.
- Axes autolubrifiants avec bagues en bronze.
- **Pas d'obligation de raccord à l'air comprimé.**
- Dispositif de contrôle de la synchronisation hydraulique des rampes.
- Vitesse de descente contrôlée par compensation hydraulique.
- Soupapes de sécurité et de blocage dans le circuit hydraulique : contrôle de la pression, anti-rupture des conduites hydraulique.
- L'huile du circuit hydraulique est fournie avec le pont.
- Chevilles de fixation au sol fournies avec le pont.

## TECHNISCHE UND KONSTRUKTIVE ANGABEN

- 4-Kolben-Hydraulikkreislauf.
- **Durch Drücken des Senkknopfes fährt die Hebebühne millimetergenau nach unten, ein wichtiges Merkmal für Präzisionsarbeiten, wie z. B. die Entnahme von schweren Bauteilen aus dem Fahrzeug.**
- Plattformverlängerungen zur Gewährleistung von Mindest- und Maximallängen ermöglichen den Hub einer Vielzahl von Fahrzeugen.
- Stifte mit selbstschmierenden Bronzebuchsen.
- **Kein Druckluftanschluss erforderlich.**
- Hydraulisch synchronisierte Plattformen mit Nivellierungssteuerung.
- Die Absenkgeschwindigkeit wird durch eine hydraulische Ausgleichseinrichtung gesteuert.
- Sicherheits- und Sperrventile am Hydraulikkreislauf, zur Druckregelung und um gegen Rohrbrüche zu schützen.
- Öl für Hydraulikkreislauf wird mitgeliefert.
- Ausgestattet mit Grundplatte.

### ART. 718/M

Modello a pavimento  
Floored model  
Modèle au sol  
Überflur-Modell

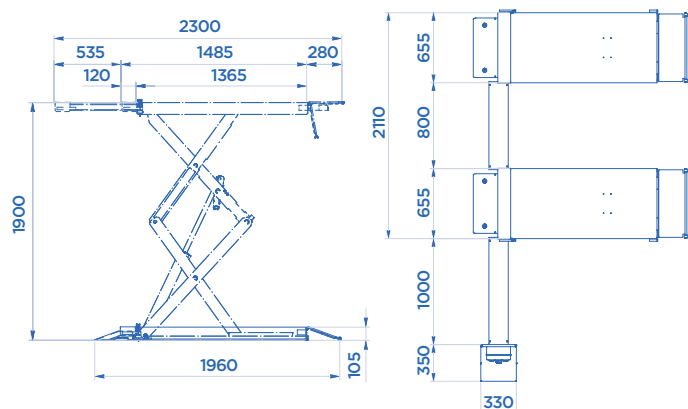

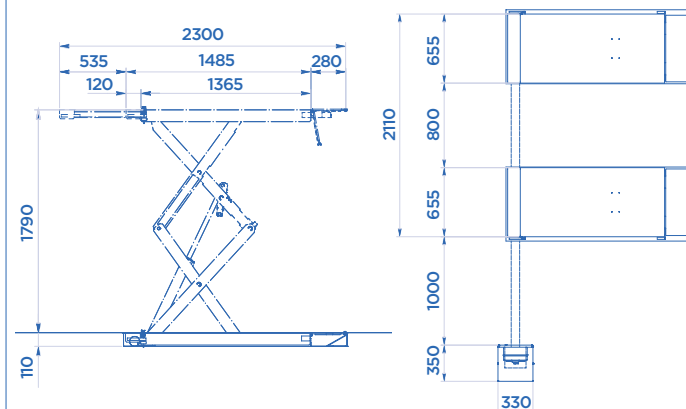

### ART. 719/M

Modello a scomparsa  
Disappearing model  
Modèle encastrable  
Unterflur-Modell



OPTIONAL Pag. 064

ART.			Motore trifase Three-phase motor Moteur triphasé Netzspannung	
718/M	3500 Kg	3,3 KW	400V • 50HZ	1030
719/M	3500 Kg	3,3 KW	400V • 50HZ	1030

 Potenza motore • Motor power • Puissance moteur • Motorleistung





ART. 552 • 553

3000 KG



ART. 552



## TRACCIATO TECNICO COSTRUTTIVO

- Particolarmente indicati per gommisti, carrozzieri e meccanici.
- **Barra di torsione doppia per il livellamento, il collegamento e la linearità delle due pedane.**
- Ingombro ridotto.
- Sicurezze meccaniche di stazionamento.
- Valvole di ritegno e sicurezza in caso di rottura dei tubi.
- Funzionamento elettroidraulico di tipo rapido.
- Comandi a bassa tensione (24 V).
- Pedanine d'accesso convertibili in prolunghe di stazionamento.
- Boccole autolubrificanti.
- Olio per circuito idraulico in dotazione.
- Tasselli di ancoraggio al suolo in dotazione.

## TECHNICAL AND STRUCTURAL LAY-OUT

- Particularly suitable for tyre-shops, car-body-shops and garages.
- **Double torsion bar for levelling, connecting and aligning the two boards.**
- Minimal overall dimensions.
- Mechanical standing safeties.
- Check and safety valves against breakage of pipes.
- Electrohydraulic rapid working.
- 24 V low-tension control.
- Drive ramps convertible into standing extension set.
- Self-lubricating bushes.
- Delivered with oil for the hydraulic circuit.
- Equipped with anchor small blocks.

## RELEVÉ TECHNIQUE

- Particulièrement indiqués pour les marchands de pneus, carrossiers et garages.
- **Barre de torsion double qui assure la mise de niveau, la liaison et la linéarité des deux plateformes.**
- Encombrement réduit.
- Sécurités mécaniques de stationnement.
- Vanne de retenue et de sécurité en cas de rupture des tuyaux.
- Fonctionnement électrohydraulique de type rapide.
- Commande basse tension (24 V).
- Rampes d'accès convertibles en rallonges de stationnement.
- Bagues en bronze autolubrifiantes.
- Livrés avec l'huile pour le circuit hydraulique.
- Chevilles d'ancrage au sol fournies.

## TECHNISCHE UND KONSTRUKTIVE ANGABEN

- Speziell geeignet für Reifen- und Reparatur- sowie Karosserieinstandsetzungs-Werkstätten.
- **Doppelte Versteifungstrebe für Nivellierung, Verbindung und Ausrichtung der beiden Fahrschienen.**
- Geringe Abmessungen.
- Hydraulische Gleichlaufregelung.
- Rückschlagventil und Sicherheitsventil im Falle eines Rohrbruchs.
- Schnell arbeitendes Hydraulikaggregat.
- Überwachung der Steuerspannung (24 V).
- Auffahrschienen können durch stationäre Verlängerungen ersetzt werden.
- Selbstschmierende Bolzen in Bronze-Buchsen.
- Wird mit Öl für die hydraulische Schaltung geliefert.
- Ausgestattet mit schmaler Grundplatte.

### ART. 552

Modello a pavimento  
Floored model  
Modèle au sol  
Überflur-Modell

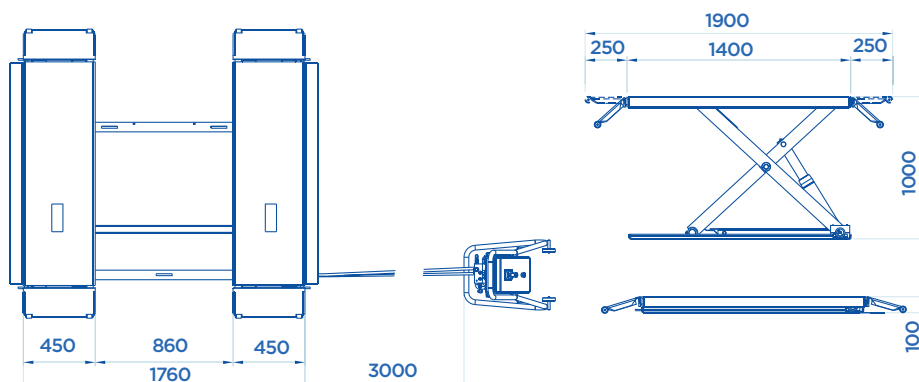

### OPTIONAL Pag. 064

ART.



Motore trifase  
Three-phase motor  
Moteur triphasé  
Netzspannung



552

3000 Kg

3,3 KW

400V • 50HZ

610

553

3000 Kg

3,3 KW

400V • 50HZ

620



Potenza motore • Motor power • Puissance moteur • Motorleistung

### ART. 553

Modello a scomparsa  
Disappearing model  
Modèle encastrable  
Unterflur-Modell

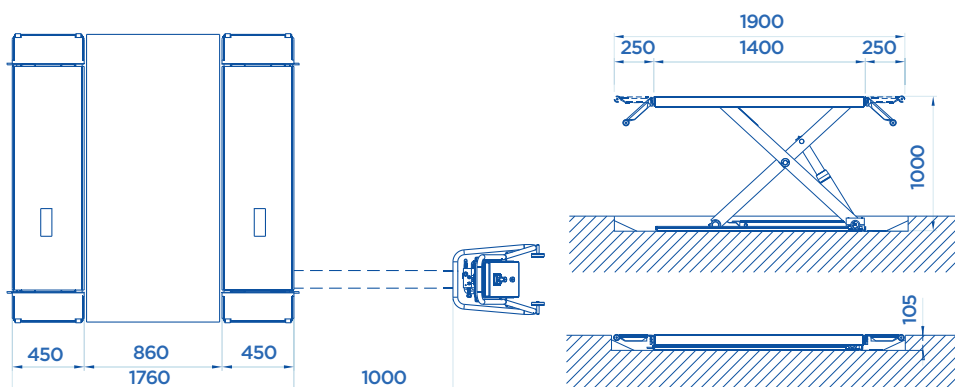



ART. 551 • 551/I

3200 KG



ART. 551

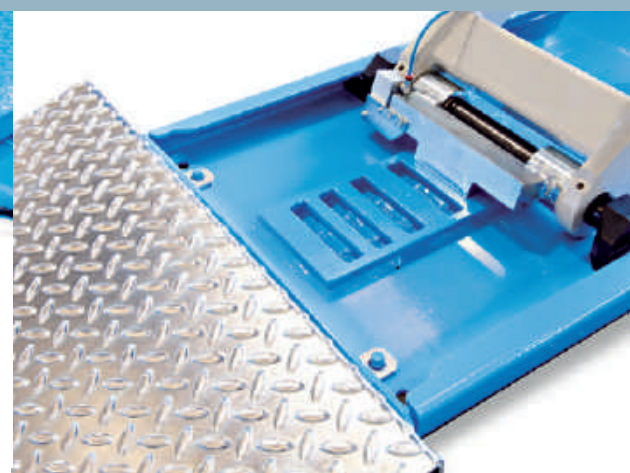
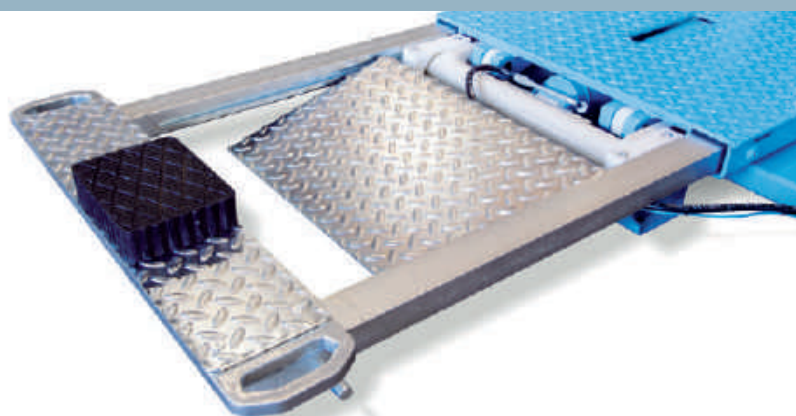
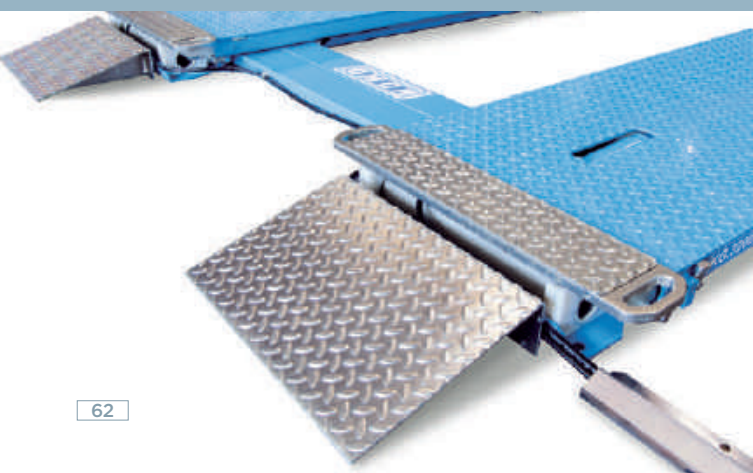

## TRACCIATO TECNICO COSTRUTTIVO

- Particolarmente indicato per gommisti e meccanici.
- **Prolunghe pedana a sfilata per garantire quote di lunghezza minima e massima che permettano il sollevamento di SUV e veicoli commerciali senza accessori aggiuntivi.**
- Pedanine d'accesso removibili.
- Ridotti ingombri d'imballaggio per il trasporto.
- Barra di torsione per il livellamento, il collegamento e la linearità delle due pedane.
- Ingombro a terra ridotto per permettere la caricabilità di vetture particolarmente basse.
- Sicurezze di stazionamento.
- Valvole di ritegno e sicurezza in caso di rottura tubi.
- Comandi di azionamento in bassa tensione (24 V) ad "uomo presente".
- Dispositivo acustico di sicurezza durante la movimentazione in discesa del sollevatore.
- Perni con boccole in bronzo autolubrificanti.
- Olio per circuito idraulico in dotazione.
- Tasselli di ancoraggio al suolo in dotazione.

## TECHNICAL AND STRUCTURAL LAY-OUT

- Particularly suitable for tyre-shops, car-body-shops and garages.
- **Extractable extensions guarantee min-max length to allow the lifting of SUV and commercial vehicles without extra accessories.**
- Removable ramps.
- Reduced packing dimensions.
- Torsion bar for levelling, connecting and aligning the two boards.
- Very low when closed down to let very low-profile cars drive on/off.
- Mechanical safeties.
- Check and safety valves against breakage of pipes.
- Low voltage 24 V "man standing-by" controls.
- Safety buzzer bips when platform go down.
- Self-lubricating pins in bronze bushes.
- Delivered with oil.
- Delivered with anchor bolts.

## RELEVÉ TECHNIQUE

- Particulièrement indiqués pour les marchands de pneus, carrossiers et garages.
- **Plateformes munies de rallonges permettent le levage des SUV et utilitaires sans devoir recourir à des accessoires.**
- Rampes d'accès détachables.
- Encombrement d'emballage réduit.
- Barre de torsion double qui assure la mise de niveau, la liaison et la linéarité des deux platesformes.
- Encombrement à terre réduit pour permettre aux voitures les plus basses de monter sans problème.
- Sécurités mécaniques.
- Vanne de retenue et de sécurité en cas de rupture des tuyaux.
- Commandes basse tension (24 V) de type "homme mort".
- Signal acoustique de sécurité pendant la descente de l'élevateur.
- Axe avec bagues en bronze autolubrifiantes.
- Huile pour circuit hydraulique fourni.
- Chevilles d'ancrage au sol fournies.

## TECHNISCHE UND KONSTRUKTIVE ANGABEN

- Besonders geeignet für Reifenspezialisten und Mechaniker.
- **Plattformverlängerungen zur Gewährleistung von Mindest- und Maximallängen ermöglichen den Hub von SUVs und Nutzfahrzeugen ohne zusätzliches Zubehör.**
- Abnehmbare Zugangsplattformen.
- Einfacher Transport dank platzsparender Verpackung.
- Torsionsstab zur Nivellierung, Verbindung und Linearität der beiden Plattformen.
- Der Hub von Fahrzeugen mit geringer Bodenfreiheit ist dank dem niedrigen Überfahrblech kein Problem.
- Tragarmarretierung.
- Rückschlag- und Sicherheitsventile bei Rohrbruch.
- Niederspannungssteuerungen (24 V), "Stand-by-Sicherung".
- Akustische Warneinrichtung während der Abwärtsbewegung der Hebebühne.
- Stifte mit selbstschmierenden Bronzebushen.
- Öl für Hydraulikkreislauf wird mitgeliefert.
- Ausgestattet mit Grundplatte.

### ART. 551

Modello a pavimento  
Floored model  
Modèle au sol  
Überflur-Modell

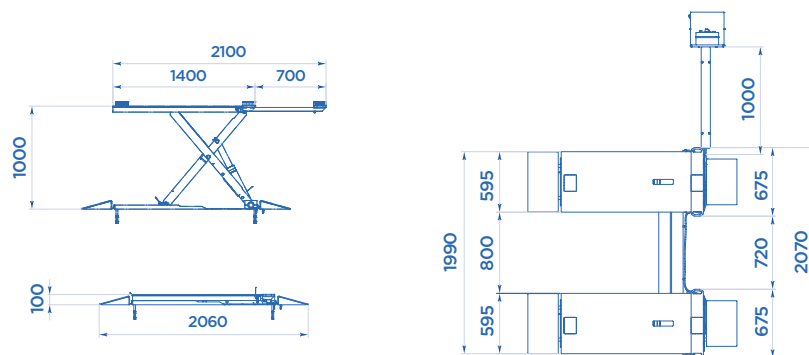

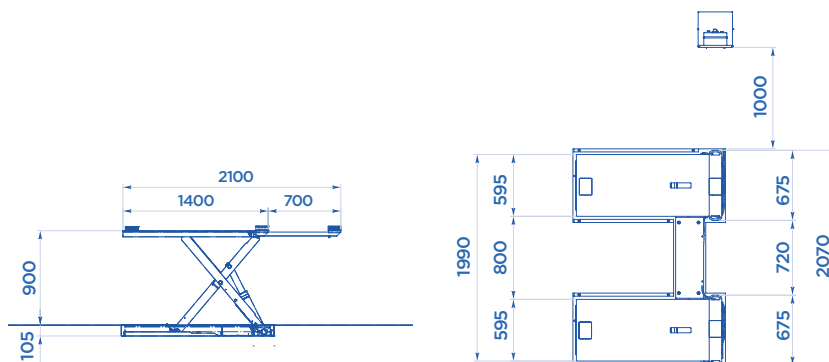

### ART. 551/I

Modello a scomparsa  
Disappearing model  
Modèle encastrable  
Unterflur-Modell



### OPTIONAL Pag. 064

ART.			Motore trifase Three-phase motor Moteur triphasé Netzspannung	
551	3200 Kg	3,3 KW	400V • 50HZ	670
551/I	3200 Kg	3,3 KW	400V • 50HZ	670

 Potenza motore • Motor power • Puissance moteur • Motorleistung



## ACCESSORI EXTRA DOTAZIONE

EXTRA EQUIPMENT • ACCESSOIRES EN OPTION • EXTRA ZUBEHÖR

**KIT X4**

### TAMPONI

Tampons  
Pads  
Gummiauflagen

ART.



mm

715	80
715/A	120
715/B	200
715/C	60
715/D	40
715/E	30

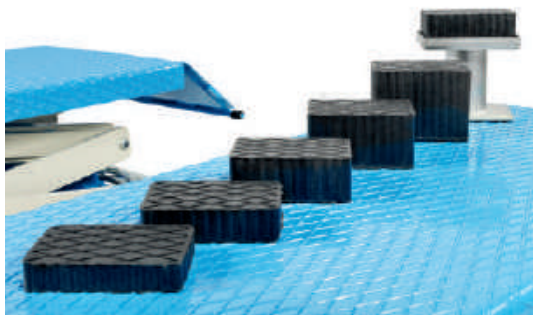

### SET DI TRAVERSE

Pair of auxiliary traverses  
Paire de traverses  
Zusätzliche Quertraversen

ART.



MAX

703 • 703/A  
705 • 705/M

714

1000 Kg X 2



ART.



MAX

730

714/A

2000 Kg X 2



ART.



MAX

718  
718/M

719  
719/M

714/B

1000 Kg X 2



714/C

1000 Kg X 2



**KIT X4**

ART. A730

### ADATTATORI

Adaptors  
Adaptateurs  
Adapter

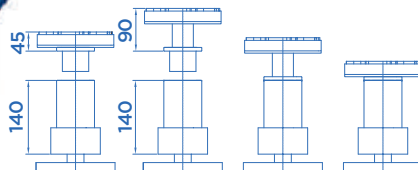

ART. A730 ✓ ART. 730

ART. B730 ✓ ART. 730

ART. B730

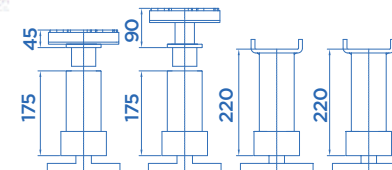

## ACCESSORI EXTRA DOTAZIONE

EXTRA EQUIPMENT • ACCESSOIRES EN OPTION • EXTRA ZUBEHÖR



### ART. 713 (1 m) PROLUNGHE DI COLLEGAMENTO TRA IL SOLLEVATORE E LA CENTRALINA DI COMANDO

Connection extensions between the hoist and the control box

Rallonges de jonction entre l'élévateur et le pupitre de commande

Verlängerungsschläuche (zwischen Hebebühne und Steuerpult)



**KIT**

**X4**

### SET DI PEDANINE

Additional run-up ramps

Rampes additionnelles

Auffahrschienen

**ART. 725/A** ✓ ART. 718

**ART. 725/B** ✓ ART. 552



### TELAJ PER INCASSO

Embedding frames

Caissons pour modèles encastrables

Metallrahmen für Grube

**ART. 711** ✓ ART. 703

**ART. 711/A** ✓ ART. 703/A

**ART. 711/B** ✓ ART. 705

**ART. 711/C** ✓ ART. 719

**ART. 711/E** ✓ ART. 730

**ART. 711/F** ✓ ART. 705/M

**ART. 711/G** ✓ ART. 719/M



### MOBILE KIT

**ART. A552** ✓ ART. 552

NOTE

---

---

---

---

---

---

---

---

---

---

---

---

---

---

---

---

---

---

---

---

---

---

---

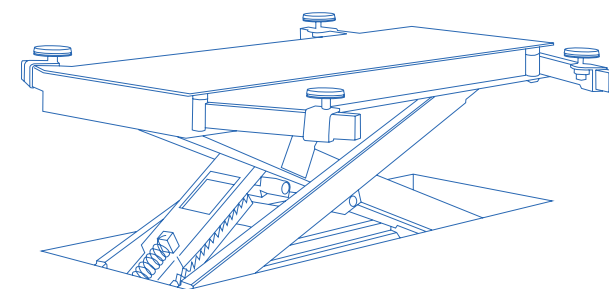

**SOLLEVATORI  
PER CARROZZERIA**

LIFTS FOR CAR-BODY SHOP  
ELEVATEURS POUR CARROSSERIE  
FAHRBARE KURZHUBBÜHNEN FÜR KAROSSERIE

Made in Italy 



ART. 541



<b>ART.</b>			<b>Motore trifase</b> Three-phase motor Moteur triphasé Netzspannung	
<b>541</b>	3000 kg	2,6 KW	400V • 50HZ	480
<b>541/IP</b>	3000 kg			480

Potenza motore • Motor power • Puissance moteur • Motorleistung

## TRACCIATO TECNICO COSTRUTTIVO

- Sollevatore super-ribassato studiato per riparazioni di carrozzeria e utilizzabile in tutti i settori dell'auto-riparazione; particolarmente indicato per il sollevamento di veicoli con carrozzeria ribassata senza necessità di realizzare la buca di incasso.
- Valvole di sicurezza e di blocco del circuito idraulico atte al controllo della pressione e contro la rottura dei tubi oleodinamici.
- Perna con bocchette autolubrificanti.
- Olio per circuito idraulico in dotazione.
- Dotato di sicurezza meccanica e di stazionamento.
- Tasselli di ancoraggio in dotazione.
- **Art. 541:** Sollevatore ad azionamento elettro-idraulico dotato di 4 bracci per il sollevamento di vetture e veicoli commerciali.
- Comandi di azionamento in bassa tensione 24 V ad "uomo presente".
- Dispositivo acustico di sicurezza durante la movimentazione in discesa del sollevatore.
- **Art. 541/IP:** Sollevatore ad azionamento idropneumatico dotato di 4 bracci per il sollevamento di vetture e veicoli commerciali.
- **Art. 542:** Accessorio extra dotazione composto da 4 pedane, portata 2.500 Kg.

## TECHNICAL AND STRUCTURAL LAY-OUT

- Low-profile lift designed to repair car-bodies, it can also be used in every kind of car-repairing shops; perfect to lift low profile vehicles if you don't want to break your floor.
- Safety and lock valves of the hydraulic circuit to control pressure and prevent any possible breakage of the pipes.
- Pins with self-lubricating bushes.
- Delivered with oil for the hydraulic circuit.
- Equipped with mechanical and parking safeties.
- Delivered with anchors.
- **Art. 541:** Electro-hydraulic lift with 4 arms to lift cars and vans.
- Low voltage man standing-by control (24V).
- Safety buzzer bips when platform go down.
- **Art. 541/IP:** Hydro-pneumatic lift equipped with 4 arms to lift cars and vans.
- **Art. 542:** Extra accessory composed by 4 footboards, capacity 2.500 Kg.

## RELEVÉ TECHNIQUE

- Élévateur extra-plat conçu pour des réparations de carrosserie et utilisable dans toutes les secteurs de la réparation automobile; particulièrement indiqué pour le levage de véhicules à bas de caisse surbaissés, sans devoir réaliser une fosse d'encastrement.
- Circuit hydraulique muni de soupape d'arrêt de sécurité pour contrôler la pression et éviter toute rupture des flexibles hydrauliques.
- Axes avec bagues autolubrifiantes.
- Huile pour circuit hydraulique fournie.
- Sécurité mécanique et de stationnement.
- Chevilles d'ancrage au sol fournies.
- **Art. 541:** Elévateur à actionnement électro-hydraulique avec 4 bras pour le levage des voitures et des utilitaires.
- Commandes en basse tension (24 V) de type «homme mort».
- Signal acoustique de sécurité pendant la descente de l'élévateur.
- **Art. 541/IP:** Elévateur à actionnement hydropneumatique avec 4 bras pour le levage des voitures et des utilitaires.
- **Art. 542:** Accessoire en option: 4 plateformes, capacité 2.500 Kg.

## TECHNISCHE UND KONSTRUKTIVE ANGABEN

- Hebebühne mit flachem Profil die für Karosserie-Reparaturen und für jeden Sektor des Fahrzeugsreparatur geeignet ist; speziell geeignet um Fahrzeuge mit Flache-Profil-Karosserie anzuheben, ohne das Bedürfnis vom Unterfluroch.
- Sicherheits- und Überdrückventile zur Überwachung der Druck und der Ölhydraulikrohre
- Bolzen mit selbstschmierenden Buchsen.
- Geliefert mit Öl für die hydraulische Schaltung.
- Mit mechanischer und Stationierung Sicherheiten.
- Mit Dübel ausgestattet
- **Art. 541:** Elektrohydraulische Hebebühne mit 4 Armen für das Heben von Fahrzeuge und Nutzfahrzeuge.
- Stand-by-Triebssteuerungen" mit Niederspannung (24 V).
- Akustisches Sicherheitssteuerung während der Absenkphase der Hebebühne.
- **Art. 541/IP:** Hydropneumatische Hebebühne mit 4 Armen für das Heben von Fahrzeuge und Nutzfahrzeuge.
- **Art. 542:** Zusätzliches Zubehör mit 4 Fahrschienen, kapazität 2.500 Kg.

ART. 541 • 541/IP

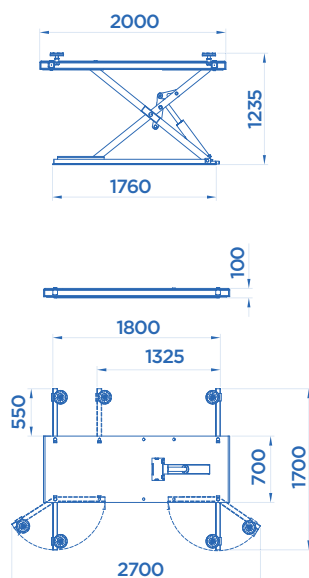

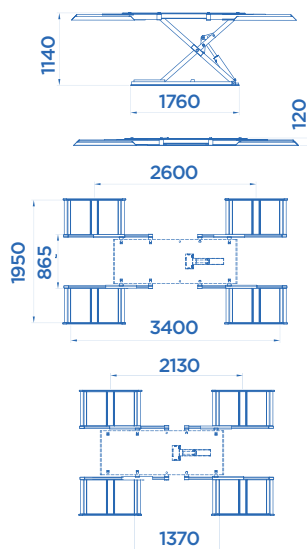

ART. 541+542

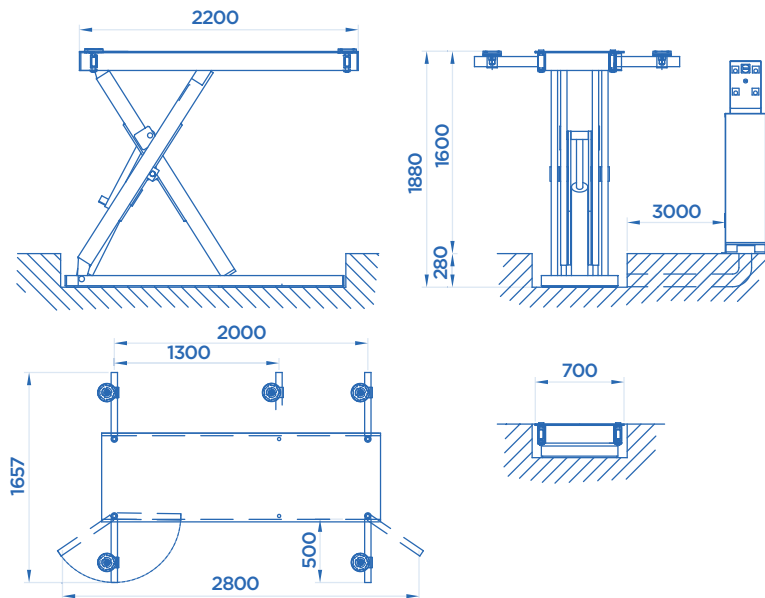
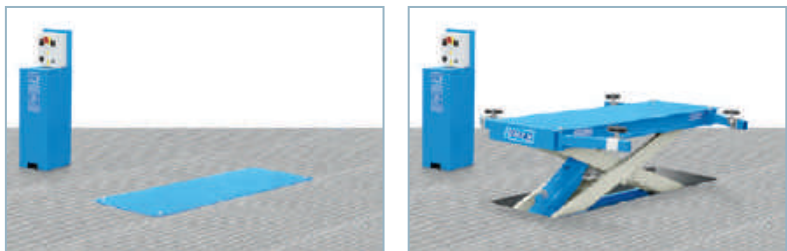

ART. 541+542



<b>ART.</b>			Motore trifase Three-phase motor Moteur triphasé Netzspannung	
<b>540/A</b>	3000 kg	3 KW	400V • 50HZ	850

 Potenza motore • Motor power • Puissance moteur • Motorleistung

## ART. 540/A

### TRACCIATO TECNICO COSTRUTTIVO

- Studiato per le riparazioni della carrozzeria e utilizzabile in tutti i settori dell'auto-riparazione.
- Dotato 4 bracci per il sollevamento delle vetture e veicoli commerciali.
- La notevole altezza e le ridotte dimensioni in larghezza della pedana, consentono di lavorare con comodità e facilità sotto il veicolo.
- Dotato di sicurezze meccaniche e di stazionamento.

### TECHNICAL AND STRUCTURAL LAY-OUT

- Studied for repairing car body it can be used in all the sectors of car repair.
- Equipped with 4 arms to lift cars and commercial vehicles.
- The remarkable lift and the minimum width dimensions of the footboard, allow to work comfortably and in an easy way under the vehicle.
- Equipped with mechanical and parking safeties.

### RELEVÉ TECHNIQUE

- Equipé de 4 bras pour soulever voitures et utilitaires.
- Son importante hauteur de levée et la largeur réduite de la plateforme facilite le travail sous véhicule et le rendent plus confortable.
- Equipé de sécurités mécaniques de stationnement.

### TECHNISCHE UND KONSTRUKTIVE ANGABEN

- Für Reparaturen an der Karosserie entwickelt und in allen Bereichen der Autoreparatur anwendbar.
- Mit 4 zusätzlichen Aufnahmen, um PKW und Lieferwagen anheben zu können.
- Der bemerkenswerte Hub und die geringe Breite der Fahrschiene, ermöglichen es bequem und einfach unter dem Fahrzeug zu arbeiten.
- Mit mechanischer Sicherung der Arbeitsstellung ausgestattet.

## TRACCIATO TECNICO COSTRUTTIVO

Questo sollevatore è stato realizzato per consentire al carrozziere di operare stando sempre in posizione verticale. Grazie alla sua versatilità trova un'ottima collocazione anche presso gommisti e meccanici riparatori, per molteplici impieghi. La sicurezza meccanica a doppia slitta, con riarmo automatico in posizione zero e la valvola paracadute tutelano in forma assoluta l'operatore. I bracci scorrevoli sul telaio e i tamponi scorrevoli, regolabili all'interno dei bracci e estraibili, consentono un perfetto posizionamento di ogni tipo di vettura, dalla più piccola alla più grande.

- **Art. 550:** Sollevatore ad azionamento elettroidraulico.
- **Art. 550/A:** Sollevatore ad azionamento idropneumatico.

## TECHNICAL AND STRUCTURAL LAY-OUT

This lifting platform has been designed to allow the body-maker/coachbuilder to always work standing upright. Thanks to its versatility it is also excellent for tyre repair shops and repair mechanics, and has numerous uses.

The double slide mechanical safety device, which has automatic rearmament on the zero position, and the valve parachute give the operator absolute protection.

The smooth sliding arms on the frame and sliding pads, adjustable inside the arms and extractable mean that every type of vehicle, from the smallest to the largest can be perfectly positioned.

The lifting platform is equipped with a displacement handle.

- **Art. 550:** Electro-hydraulic lift.
- **Art. 550/A:** Hydro-pneumatic lift.

## RELEVÉ TECHNIQUE

Elévateur réalisé pour faciliter le travail du carrossier et lui permettre de travailler debout. Très polyvalent, il trouve une place de choix chez les garagistes comme chez les marchands de pneus. Sécurité absolue pour l'opérateur grâce à un système de cliquets et clapet anti-retour.

Les bras coulissent le long du bâti tandis que les tampons coulissent le long des bras (réglage à l'intérieur des bras), pour permettre un positionnement parfait des voitures, de la plus petite à la plus grande.

L'élévateur se déplace à l'aide d'une poignée.

- **Art. 550:** Elévateur à actionnement électro-hydraulique.
- **Art. 550/A:** Elévateur à actionnement hydro-pneumatique.

## TECHNISCHE UND KONSTRUKTIVE ANGABEN

Diese Hebebühne erlaubt es dem Karosseriefachmann immer in aufrechter Haltung zu arbeiten. Dank ihrer Vielseitigkeit und verschiedenartigen Anwendungsmöglichkeiten ist sie besonders für Reifen- und Reparaturwerkstätten geeignet.

Absolute Sicherheit für das Bedienungspersonal gewährleisten ein Sicherheitsventil und eine mechanische Sicherheitseinrichtung auf Doppelgleitschienen mit automatischer Zurückstellung in die Position -Null-.

Da die Tragarme und die Auflagepolster verstellbar und herausziehbar sind, ist eine perfekte Anpassung der Hebebühne an jedes Auto - ob klein oder groß - möglich.

Die Hebebühne ist ausgestattet mit einem beweglichen Griff.

- **Art. 550:** Elektrohydraulische Hebebühne.
- **Art. 550/A:** Hydro-pneumatische Hebebühne.

ART. 550/A

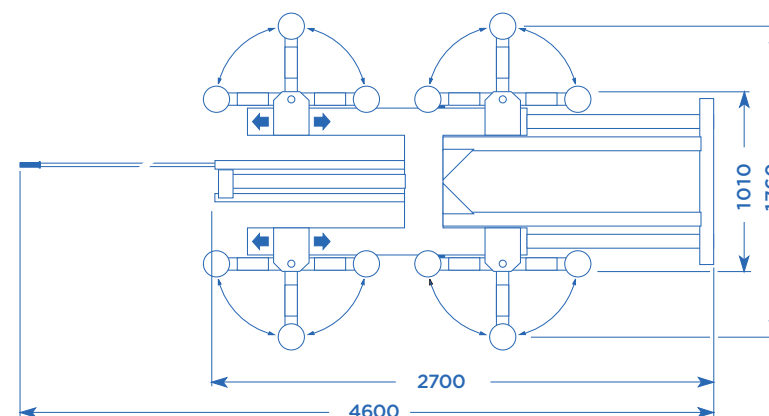

ART.			Motore trifase Three-phase motor Moteur triphasé Netzspannung		
<b>550</b>	2500 kg	1,5 KW	400V • 50HZ	130	1000
<b>550/A</b>	2500 kg			130	1000

Potenza motore • Motor power • Puissance moteur • Motorleistung





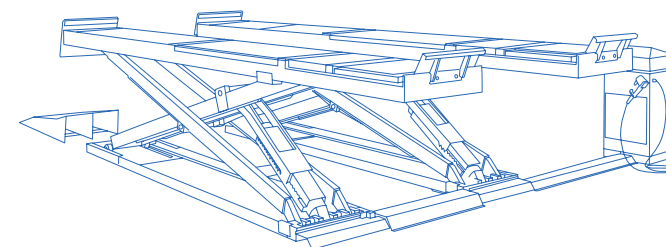

**PONTI SOLLEVATORI  
ELETTROIDRAULICI A FORBICE**

ELECTROHYDRAULIC SCISSOR LIFTS  
PONTIS ELEVATEURS A CISEAUX ELECTROHYDRAULIQUES  
ELEKTROHYDRAULISCHE SCHEREN-HEBEBÜHNEN

Made in Italy 

# PONTI SOLLEVATORI ELETTROIDRAULICI A FORBICE

## ELECTROHYDRAULIC SCISSOR LIFTS

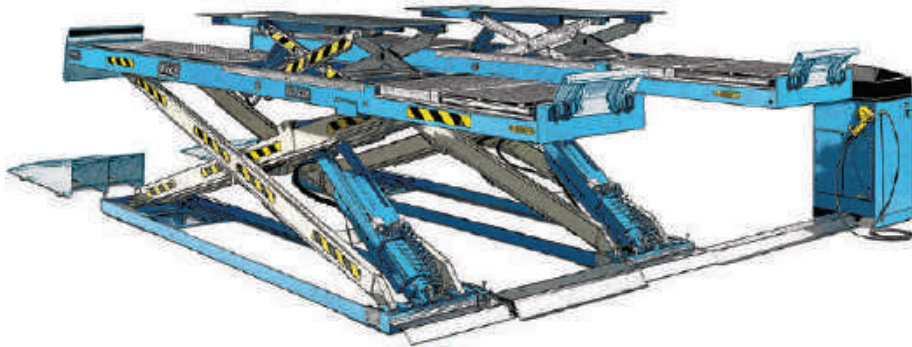

### TRACCIATO TECNICO COSTRUTTIVO

- Modelli a pavimento ed a incasso.
- Funzionamento elettroidraulico dotato di valvole di sicurezza, controllo velocità discesa, sovraccarico e rotture accidentali dei tubi di alimentazione.
- Dispositivo meccanico ad inserimento automatico presente su entrambe le pedane per garantire la massima sicurezza.
- Parallelismo idraulico ed allineamento sincrono delle pedane indipendente dalla ripartizione del carico.
- Livellamento automatico garantito ad ogni singola discesa.
- Sistema di comando del sollevatore a bassa tensione del tipo ad azione mantenuta, per assicurare l'immediata interruzione del movimento al rilascio dei comandi.
- Avvisatore acustico di sicurezza e comando a due mani nell'ultima fase di discesa.
- **Zona di lavoro tra le pedane completamente libera da collegamenti meccanici per assicurare la massima libertà di movimento e la massima operatività.**
- Possibilità su richiesta di installare in posizione diversa dallo standard la centrale di comando.
- Perna con bocche in bronzo autolubrificanti.
- Olio per circuito idraulico in dotazione.
- Tasselli di ancoraggio al suolo in dotazione.

### TECHNICAL AND STRUCTURAL LAY-OUT

- Surface mount and floor flush models.
- Electro-hydraulic functioning with safety valves to control the descent speed, the overload and any accidental breakage of the feeding hoses.
- Mechanical rack device on both footboards to ensure the maximum safety.
- Hydraulic parallelism and synchronized alignment of the platforms independently from the load distribution.
- Automatic leveling at every single descending phase.
- Low-pressure hold-to-run control device of the lift to allow the immediate interruption of the lift as soon as control devices are released.
- Safety sound device and two hand control during the last descending phase.
- **Completely free of any mechanical connections area between runways to allow you to move and work without any restriction.**
- Possibility to install the control box in a different position on demand.
- Pins with self-lubricating bronze bushes.
- Delivered with oil for the hydraulic circuit.
- Delivered with anchor bolts.



# PONTS ELEVATEURS A CISEAUX ELECTROHYDRAULIQUES

## ELEKTROHYDRAULISCHE SCHEREN-HEBEBÜHNEN

### RELEVÉ TECHNIQUE

- Modèles encastrés ou au sol.
- A fonctionnement électro-hydraulique avec soupapes de sécurité, contrôle vitesse de descente, surcharge et rupture accidentelle des tuyaux d'alimentation.
- Dispositif mécanique à insertion automatique sur les deux rampes pour garantir un maximum de sécurité.
- Parallélisme hydraulique et alignement synchrone des rampes indépendamment de la distribution de charge.
- Remise à niveau en automatique à chaque descente.
- Système de commandes à action maintenue en basse tension pour que le mouvement s'interrompe dès que les commandes sont relâchées.
- Signal acoustique de sécurité et commandes à deux mains dans la dernière phase de descente.
- **Aire de travail entre les rampes complètement libérée de toute connexion mécanique afin de permettre une liberté de mouvement optimale et une excellente opérativité.**
- Emplacement du pupitre modifiable sur demande.
- Axes avec bagues en bronze autolubrifiantes.
- Huile pour circuit hydraulique fournie.
- Chevilles d'ancrage au sol fournies.

### TECHNISCHE UND KONSTRUKTIVE ANGABEN

- Überflur- und Unterflurmodelle.
- Elektrohydraulischer Betrieb mit Sicherheitsventile zur Kontrolle der Absenkgeschwindigkeit, mit Sicherheitsventil zur Überlastung und mit einer Sicherheitsventil zur Überwachung der Druckleitungen.
- Automatische mechanische Vorrichtung für die Einrastung auf beiden Auffahrschienen um die maximale Sicherheit zu sichern.
- Perfekte, hydraulische Gleichlaufregelung, d.h. synchronisierte (aufeinander abgestimmte) Ausrichtung der Fahrschienen unabhängig von der Lastverteilung.
- Automatisches Nivellierung während jeder Absenkphase.
- Niederspannungssteuerung der Hebebühne mit Rastfunktion, um die Bewegung zu unterbrechen wenn die Steuerungen freigelassen geworden sind.
- Akustisches Sicherheitssignal und Zweistand-Steuerung während der letzten Absenkphase.
- **Arbeitsbereich zwischen den Fahrschienen ohne mechanische Verbindung, um maximale Bewegungsfreiheit und Betrieb zu sichern.**
- Auf Kundenwunsch kann die Steuereinheit in eine verschiedener Lage eingebaut werden.
- Selbstschmierende Bolzen in Bronze-Buchsen.
- Mit Öl für die hydraulische Schaltung ausgestattet.
- Mit schmaler Grundplatte ausgestattet.

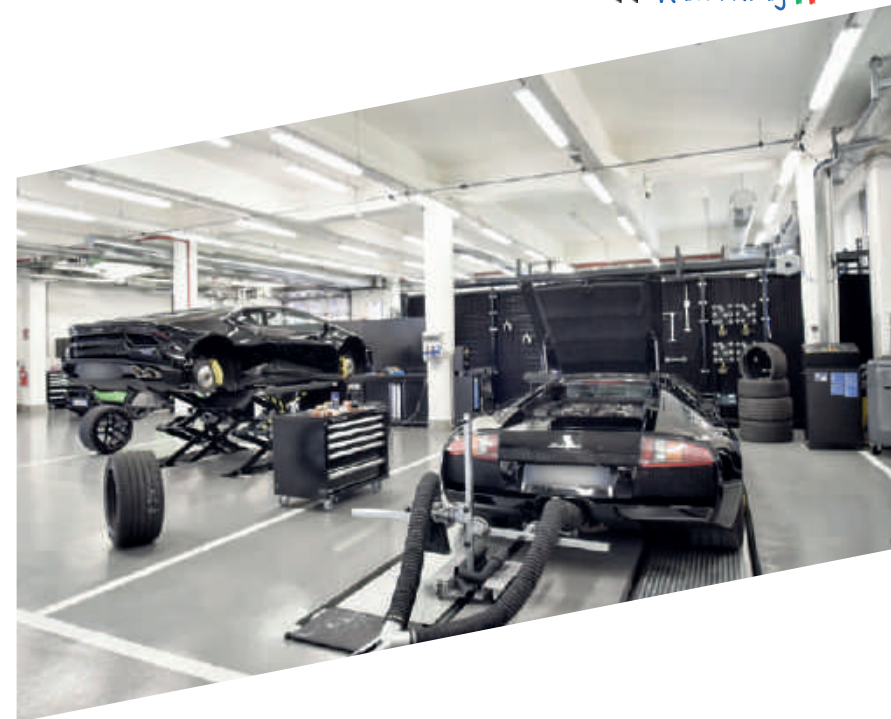

**MODELLI A PEDANE PIANE**  
**MODELS WITH FLAT PLATFORMS**  
**MODELES AVEC CHEMINS DE ROULEMENT NUS**  
**MODELLE MIT FLACHEN FAHRSCHIENEN**

**3500**  
**4000**  
**5000** | **KG**



4 TON.



5 TON.



ART. 820+853/A

**OPTIONAL** Pag. 084



Modello a pavimento  
Floored model  
Modèle au sol  
Überflur-Modell

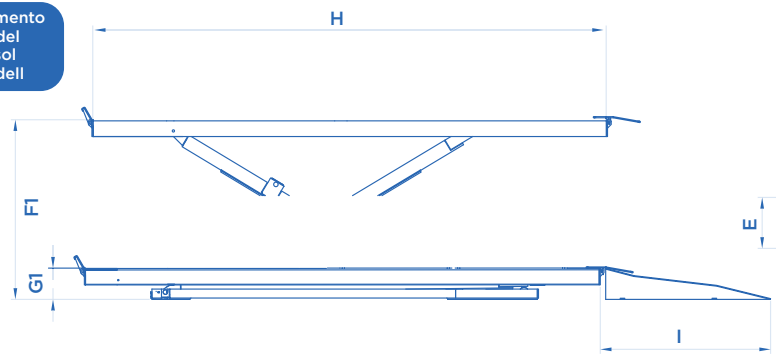

Modello a scomparsa  
Disappearing model  
Modèle encastrable  
Unterflur-Modell

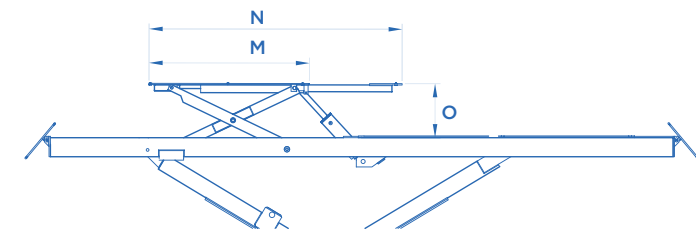
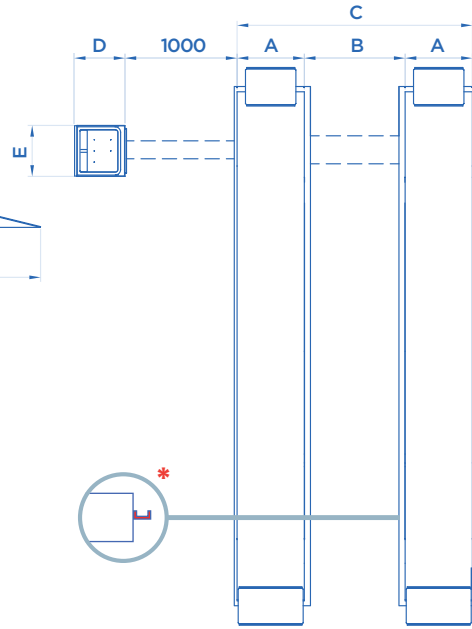
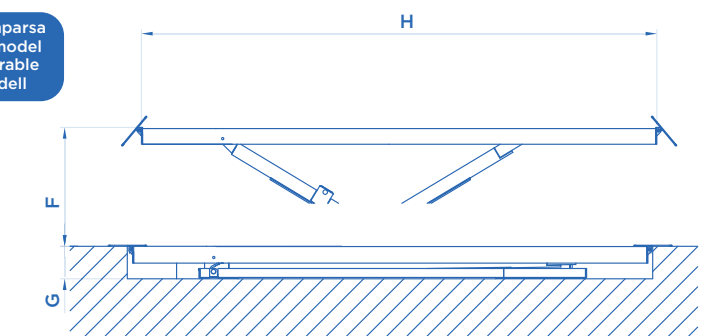

ART. M mm N mm O mm

824 • 824/I	3000 Kg	1420	1870	400
804 • 814	4000 Kg	1465	2000	400

ART.			Motore trifase Three-phase motor Moteur triphasé Netzspannung	A mm	B mm	C mm	D mm	E mm	F mm	F1 mm	G mm	G1 mm	H mm	I mm	KG	
<b>835</b> 835/I	3500 Kg	3,3 KW	400V • 50HZ	650 650	900 900	2200 2200	460 460	450 450	1800	1880	290	280	5100 5100	1500	1820 1670	
<b>820</b> 820+853/A 820/I	4000 Kg	3,3 KW	400V • 50HZ	600	900	2100	460	450		1880		280	4600	1500	1970	
820/I+853/A				600	900	2100	460	450	1800		290		280	4600	1500	2020
<b>824</b>				600	900	2100	460	450	1800		290		280	4600	1500	1690
824+853/A				600	900	2100	460	450	1880		280		280	4600	1500	1740
824/I				600	900	2100	460	450	1880		280		280	4600	1500	2380
824/I+853/A	600	900	2100	460	450	1800		290		290	4600	1500	2100	2430		
824/I+853/A	600	900	2100	460	450	1800		290		290	4600	1500	2150	2150		
<b>800</b> 800+853/B	5000 Kg	4 KW	400V • 50HZ	650	900	2200	500	550		1880		280	4900	1700	2350	
<b>810</b>				650	900	2200	500	550		1880		280	4900	1850	2420	
810+853/B				650	900	2200	500	550	1800		290		290	4900	1850	2070
<b>804</b>				650	900	2200	500	550	1800		290		290	4900	1700	2140
804+853/B				650	900	2200	500	550	1880		280		280	4900	1700	2850
<b>814</b>				650	900	2200	500	550	1880		280		280	4900	1850	2920
814+853/B	650	900	2200	500	550	1800		290		290	4900	1850	2600	2670		
814+853/B	650	900	2200	500	550	1800		290		290	4900	1850	2600	2670		

**MODELLI PER ASSETTO RUOTE  
WHEEL ALIGNMENT MODELS  
MODELES POUR GEOMETRIE ROUES  
MODELLE GEEIGNET ZUR ACHSVERMESSUNG**

**4000  
5000 KG**



4 TON.



5 TON.



ART. 822+853/A

**OPTIONAL** Pag. 084

**TRACCIATO TECNICO  
CONSTRUTTIVO**

- Incavo anteriore per alloggiamento dei piatti rotanti dotato di piastra zincata regolabile.
- **Piastre oscillanti posteriori con superficie antiscivolo e zincata.**
- Bloccaggio e sbloccaggio delle piastre oscillanti tramite comando pneumatico posto sulla centrale di comando.
- Sensore di prossimità per stazionamento millimetrico.

**TECHNICAL AND  
STRUCTURAL LAY-OUT**

- Front slots for rotating plates with a zinc-plated adjustable plate.
- **Rear oscillating plates with a slip-resistant and zinc-plated surface.**
- Locking and unlocking oscillating plates by a pneumatic control on the main control unit.
- Proximity sensor for an extremely precise parking.

**RELEVÉ TECHNIQUE**

- Logement avant pour plateaux tournants avec plaque en zinc réglable.
- **Plaques de ripage arrière avec surface antiglisse en zinc.**
- Verrouillage et déverrouillage des plaques par commande pneumatique sur le pupitre.
- Capteur de proximité pour un stationnement au millimètre.

**TECHNISCHE UND  
KONSTRUKTIVE ANGABEN**

- Vorderer Aussparung für die Stellung des Drehellers mit einstellbarer verzinkten Platte.
- **Hinterdoppelschiebeplatten mit einem rutschfester und verzinkter Oberfläche.**
- Sperrung und Abspannung der Schwingungsplatten mit einer pneumatischer Steuerung auf der Steuereinheit.
- Annäherungssensor für eine millimetergenaue Stationierung.

Modello a pavimento  
Floored model  
Modèle au sol  
Überflur-Modell

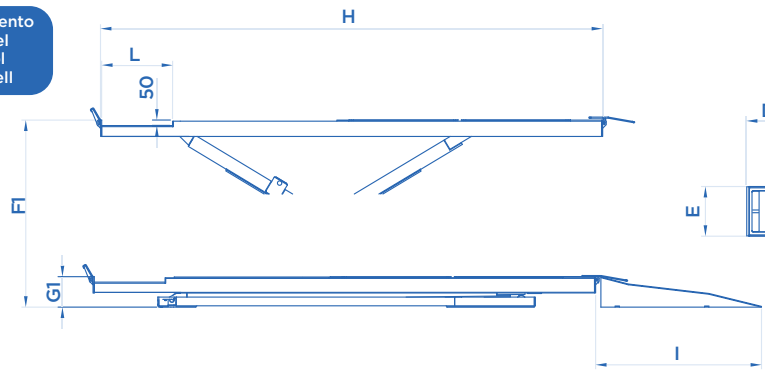

Modello a scomparsa  
Disappearing model  
Modèle encastrable  
Unterflur-Modell

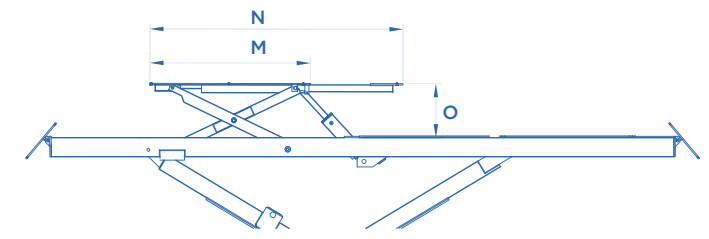
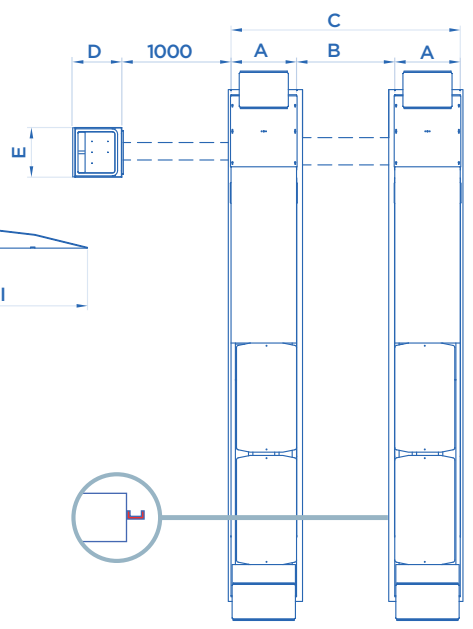
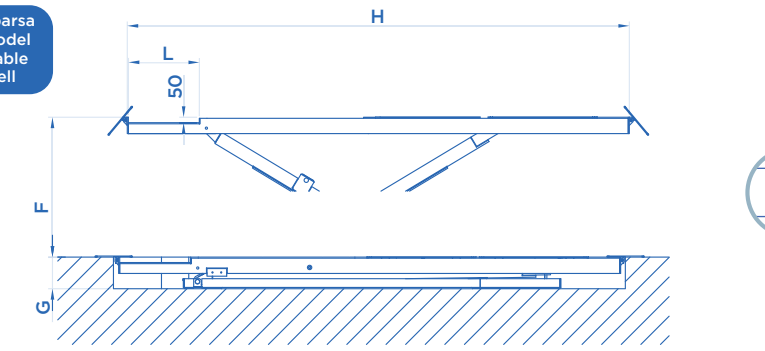

<b>ART.</b>		<b>M</b> mm	<b>N</b> mm	<b>O</b> mm
-------------	--	-------------	-------------	-------------

<b>822 • 822/I</b>	3000 Kg	1420	1870	400
<b>802 • 812</b>	4000 Kg	1465	2000	400

ART.			Motore trifase Three-phase motor Moteur triphasé Netzspannung	A mm	B mm	C mm	D mm	E mm	F mm	F1 mm	G mm	G1 mm	H mm	I mm	L mm	KG			
<b>821</b>	4000 Kg		3,3 KW	400V • 50HZ	600	900	2100	460	450				280	4600	1500	650	2090		
<b>821+853/A</b>					600	900	2100	460	450			1880		280	<b>5100</b>	1500	1100	2140	
<b>821/I</b>					600	900	2100	460	450	1800				290		4600		650	1820
<b>821/I+853/A</b>					600	900	2100	460	450	1800				290		<b>5100</b>		1100	1870
<b>822</b>					600	900	2100	460	450				1880		280	4600	1500	650	2390
<b>822+853/A</b>					600	900	2100	460	450				1880		280	<b>5100</b>	1500	1100	2440
<b>822/I</b>	5000 Kg		4 KW	400V • 50HZ	600	900	2100	460	450	1800			4600		650	2100			
<b>822/I+853/A</b>					600	900	2100	460	450	1800			290		<b>5100</b>		1100	2150	
<b>801</b>					650	900	2200	500	550				1880		280	4900	1700	1100	2470
<b>801+853/B</b>	5000 Kg		4 KW	400V • 50HZ	650	900	2200	500	550				280	4900	1850	1100	2540		
<b>811</b>					650	900	2200	500	550	1800			290		4900		1100	2220	
<b>811+853/B</b>					650	900	2200	500	550	1800				290		<b>5400</b>		1100	2170
<b>802</b>					650	900	2200	500	550				1880		280	4900	1700	1100	2890
<b>802+853/B</b>					650	900	2200	500	550				1880		280	<b>5400</b>	1850	1100	2960
<b>812</b>					650	900	2200	500	550	1800				290		4900		1100	2600
<b>812+853/B</b>	650	900	2200	500	550	1800				290		<b>5400</b>		1100	2670				



**MODELLI PER ASSETTO CON PROVAGIOCHI**  
**ALIGNMENT MODELS WITH PLAY DETECTOR**  
**MODELES POUR GEOMETRIE AVEC PLAQUES A JEUX**  
**ACHSMESSEMODELLE MIT GELENKSPIELTESTERN**

**4000** | **5000** **KG**



4 TON.



5 TON.



ART. 823

**OPTIONAL** Pag. 084

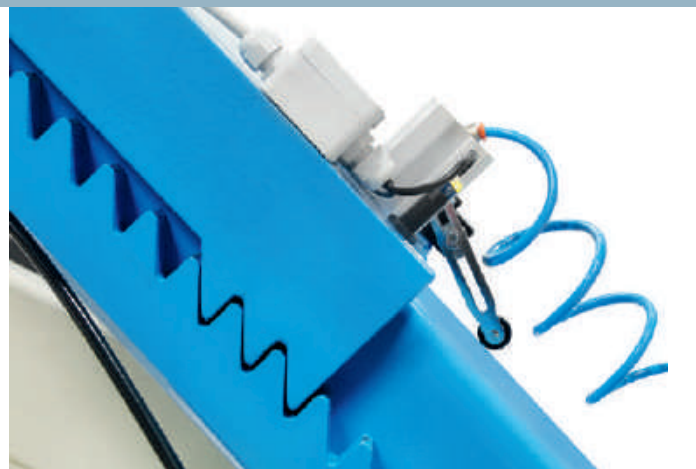

## TRACCIATO TECNICO COSTRUTTIVO

- Piastre provagiochi di grandi dimensioni con superficie antiscivolo e zincata.
- Incavo anteriore per alloggiamento dei piatti rotanti dotato di piastra zincata regolabile.
- Piastre oscillanti posteriori con superficie antiscivolo e zincata.
- **Bloccaggio e sbloccaggio delle piastre oscillanti tramite comando pneumatico posto sulla centrale di comando.**
- Sensore di prossimità per stazionamento millimetrico.

## TECHNICAL AND STRUCTURAL LAY-OUT

- Big play detector plates with a slip-resistant zinc-plated surface.
- Front slots for rotating plates with a zinc-plated adjustable plate.
- Rear oscillating plates with a slip-resistant and zinc-plated surface.
- **Locking and unlocking oscillating plates by pneumatic control on the main control unit.**
- Proximity sensor for an extremely precise parking.

## RELEVÉ TECHNIQUE

- Plaques à jeux de grandes dimensions, surface antiglisse en zinc.
- Logement avant pour plateaux tournants avec plaque en zinc réglable.
- Plaques de ripage arrière avec surface antiglisse en zinc.
- **Verrouillage et déverrouillage des plateaux par commande pneumatique sur le pupitre.**
- Capteur de proximité pour un stationnement au millimètre.

## TECHNISCHE UND KONSTRUKTIVE ANGABEN

- Große Gelenkspielsplatte mit rutschfester und verzinkter Oberfläche.
- Vorderer Aussparung für die Stellung des Drehtellers mit einstellbarer verzinkter Platte.
- Hinterdoppelschiebeplatten mit rutschfester und verzinkter Oberfläche.
- **Sperrung und Abspannung der Schwingungsplatten mit pneumatischer Steuerung auf der Steuereinheit.**
- Annäherungssensor für eine millimetergenaue Stationierung.



### PROVAGIOCHI A 4 MOVIMENTI

4 movement play detector  
Plaques à jeux 4 mouvements  
4 Bewegungen Gelenkspieltester

Modello a pavimento  
Floored model  
Modèle au sol  
Überflur-Modell



Modello a scomparsa  
Disappearing model  
Modèle encastrable  
Unterflur-Modell

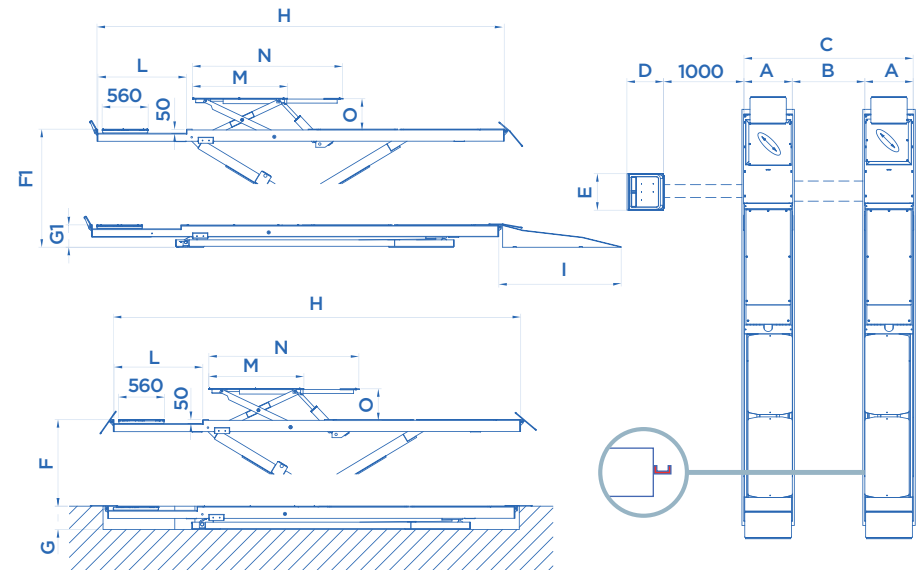

ART.				Motore trifase Three-phase motor Moteur triphasé Netzspannung	A mm	B mm	C mm	D mm	E mm	F mm	F1 mm	G mm	G1 mm	H mm	I mm	L mm	M mm	N mm	O mm	KG
<b>823</b> <b>823/I</b>	4000 Kg	3000 Kg	3,3 KW	400V • 50HZ	600	900	2100	460	450		1880		280	5100	1500	1100	1420	1870	400	2650
					600	900	2100	460	450	1800		290	5100		1100	1420	1870	400	2350	
<b>803</b> <b>803+853/B</b> <b>813</b> <b>813+853/B</b>	5000 Kg	4000 Kg	4 KW	400V • 50HZ	650	900	2200	500	550		1880		280	4900	1700	1100	1465	2000	400	3000
					650	900	2200	500	550	1880		280	<b>5400</b>	1850	1100	1465	2000	400	3070	
					650	900	2200	500	550	1800		290	4900		1100	1465	2000	400	2750	
					650	900	2200	500	550	1800		290	<b>5400</b>		1100	1465	2000	400	2820	

**MODELLI CON PROVAGIOCHI**  
**MODELS WITH PLAY DETECTOR**  
**MODELES AVEC PLAQUES A JEUX**  
**MODELLE MIT GELENKSPIELTESTERN**

**3500**  
**4000**  
**5000** **KG**

**PROVAGIOCHI A 4 MOVIMENTI**  
 4 movement play detector  
 Plaques à jeux 4 mouvements  
 4 Bewegungen Gelenkspieltester

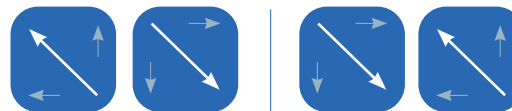

ART. 840/I **OPTIONAL** Pag. 084

**TRACCIATO TECNICO  
 COSTRUTTIVO**

- **Piastre provagiochi di grandi dimensioni con superficie antiscivolo e zincata.**
- Zona di lavoro tra le pedane completamente libera da collegamenti meccanici per assicurare la massima libertà di movimento e la massima operatività.
- Dispositivo meccanico ad inserimento automatico presente su entrambe le pedane per garantire la massima sicurezza.
- Livellamento automatico garantito ad ogni singola discesa.

**TECHNICAL AND  
 STRUCTURAL LAY-OUT**

- **Big play detector plates with a slip-resistant zinc-plated surface.**
- Completely free of any mechanical connections area between runways to allow you to move and work without any restriction.
- Mechanical rack device on both footboards to ensure the maximum safety.
- Automatic leveling at every single descending phase.

**RELEVÉ TECHNIQUE**

- **Plaques à jeux de grandes dimensions, surface antiglisse en zinc.**
- Aire de travail entre les rampes complètement libérée de toute connexion mécanique afin de permettre une liberté de mouvement optimale et une excellente opérativité.
- Dispositif mécanique à insertion automatique sur les deux rampes pour garantir un maximum de sécurité.
- Remise à niveau en automatique à chaque descente.

**TECHNISCHE UND  
 KONSTRUKTIVE ANGABEN**

- **Große Gelenkspielsplatte mit rutschfester und verzinkter Oberfläche.**
- Arbeitsbereich zwischen den Fahrschienen ohne mechanische Verbindung, um maximale Bewegungsfreiheit und Betrieb zu sichern.
- Automatisches mechanisches Vorrichtung für die Einrastung auf beiden Auffahrschienen, um die maximale Sicherheit zu sichern.
- Automatisches Nivellierung während jeder Absenkhphase.

Modello a pavimento  
Floored model  
Modèle au sol  
Überflur-Modell

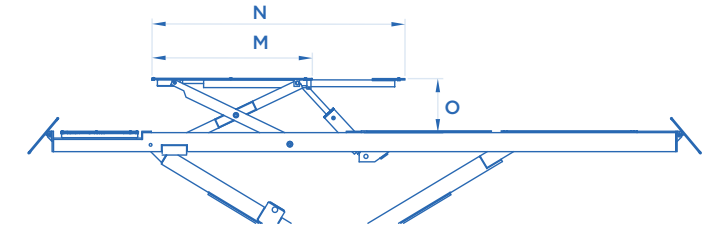
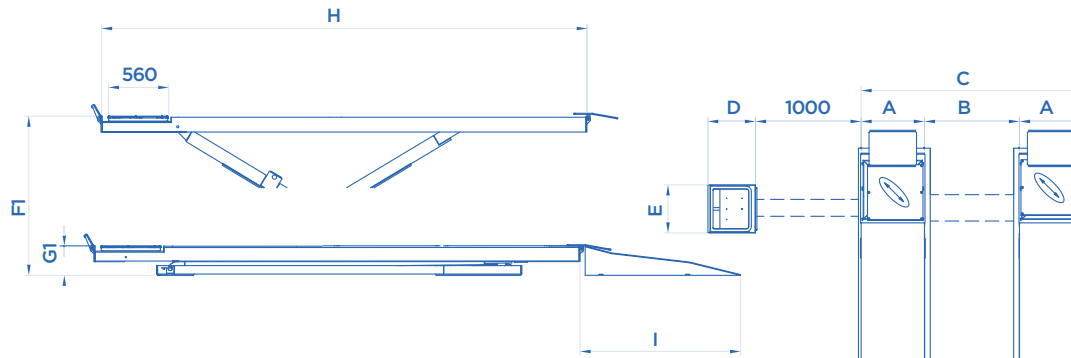

ART.	LIFT TABLE	M mm	N mm	O mm
825 • 825/I	3000 Kg	1420	1870	400
805 • 815	4000 Kg	1465	2000	400

Modello a scomparsa  
Disappearing model  
Modèle encastrable  
Unterflur-Modell

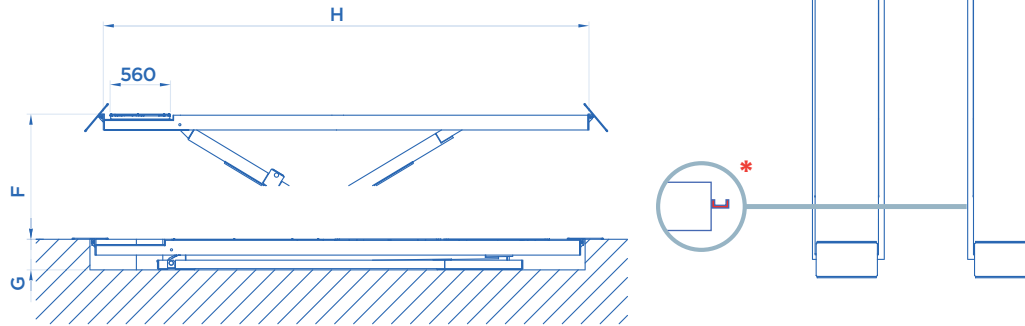

ART.	LIFT TABLE	Motor	Motor power	A mm	B mm	C mm	D mm	E mm	F mm	F1 mm	G mm	G1 mm	H mm	I mm	KG	
<b>840</b> <b>840/I</b>	3500 Kg	4 KW	400V • 50HZ	650	900	2200	460	450	1880		290	280	5100	1500	1900	
				650	900	2200	460	450	1800				5100		1750	
<b>825</b> <b>825+853/A</b> <b>825/I</b>	4000 Kg	3,3 KW	400V • 50HZ	600	900	2100	460	450	1880			280	4600	1500	2490	
600				900	2100	460	450	1880		280		<b>5100</b>	1500	2540		
600				900	2100	460	450	1800	290	4600		<b>5100</b>		2200		
<b>826</b> <b>826+853/A</b> <b>826/I</b>				600	900	2100	460	450	1800		1880		280	4600	1500	2100
600				900	2100	460	450	1880		1880		280	<b>5100</b>	1500	2150	
<b>826/I+853/A</b>				600	900	2100	460	450	1800	290	4600		<b>5100</b>		1850	
				600	900	2100	460	450	1800		290	<b>5100</b>		1900		
<b>805</b> <b>805+853/B</b> <b>815</b> <b>815+853/B</b> <b>805/A</b> <b>805/A+853/B</b> <b>815/A</b> <b>815/A+853/B</b>	5000 Kg	4 KW	400V • 50HZ	650	900	2200	500	550	1880			280	4900	1700	3040	
650				900	2200	500	550	1880		280		<b>5400</b>	1850	3110		
650				900	2200	500	550	1800	290	4900		<b>5400</b>		2750		
650				900	2200	500	550	1800	290	4900		<b>5400</b>		2820		
650				900	2200	500	550	1880		4900	1700			2480		
650				900	2200	500	550	1880		280	4900	1850	<b>5400</b>		2550	
650				900	2200	500	550	1800	290	4900					2230	
650				900	2200	500	500	1800	290	<b>5400</b>					2300	

## ACCESSORI EXTRA DOTAZIONE

EXTRA EQUIPMENT • ACCESSOIRES EN OPTION • EXTRA ZUBEHÖR

**KIT X4**

### TAMPONI

Tampons  
Pads  
Gummiauflagen

ART.



mm

<b>715</b>	80
<b>715/A</b>	120
<b>715/B</b>	200
<b>715/C</b>	60
<b>715/D</b>	40
<b>715/E</b>	30



**KIT X2**

### ART. 846 KIT PER LA SALITA E DISCESA PARTE ANTERIORE

Up and down kit, front side  
Kit pour la montée et descente partie antérieure  
2 Überfahrtschienen (vorn)

L = 1.500 mm.



### ART. 848 SET DI TRAVERSE

Pair of auxiliary traverses  
Paire de traverses  
Zusätzliche Quertraversen



1000 Kg X 2

## ACCESSORI EXTRA DOTAZIONE

EXTRA EQUIPMENT • ACCESSOIRES EN OPTION • EXTRA ZUBEHÖR

### IMPIANTO DI ILLUMINAZIONE A LED

Led lighting system  
Kit d'éclairage led  
LED Beleuchtungsanlage



**ART. 845** ✓ H = 4600 • 4900 • 5100 mm  
**ART. 845/A** ✓ H = 5400 mm



**KIT**

### ART. PLUS MORSA DI BLOCCAGGIO RUOTA PER MOTOVEICOLI E PEDANINE SUPPLEMENTARI

**ART.**

Modelli  
per linee di revisione  
(840/I • 826/I • 815/A)



**PLUS**

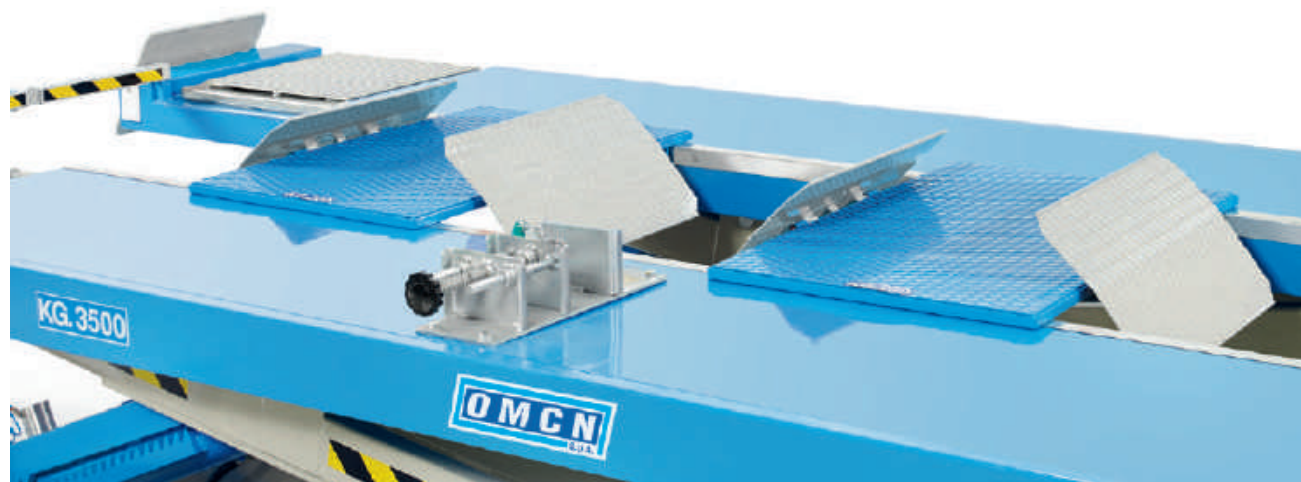

### TELAI PER INCASSO

Embedding frames  
Caissons pour modèles encastrables  
Metallrahmen für Grube



**ART. 847** ✓ H = 4600 mm  
**ART. 847/A** ✓ H = 4900 mm  
**ART. 847/B** ✓ H = 5100 mm  
**ART. 847/C** ✓ H = 5400 mm  
**ART. 847/D** ✓ ART. 835/I • 840/I

### PROLUNGHE DI COLLEGAMENTO TRA IL SOLLEVATORE E LA CENTRALINA DI COMANDO (1 m)

Connection extensions between the hoist and the control box  
Rallonges de jonction entre l'élévateur et le pupitre de commande  
Verlängerungsschläuche (zwischen Hebebühne und Steuerpult)



**ART. 852** ✓ ART. 800 • 801 • 810 • 811 • 820 • 820/I • 821 • 821/I • 835 • 835/I  
**ART. 852/A** ✓ ART. 803 • 805 • 813 • 815 • 823 • 823/I • 825 • 825/I  
**ART. 852/B** ✓ ART. 802 • 804 • 805/A • 812 • 814 • 815/A • 822 • 822/I • 824 • 824/I • 826 • 826/I • 840 • 840/I

## ACCESSORI EXTRA DOTAZIONE

EXTRA EQUIPMENT • ACCESSOIRES EN OPTION • EXTRA ZUBEHÖR

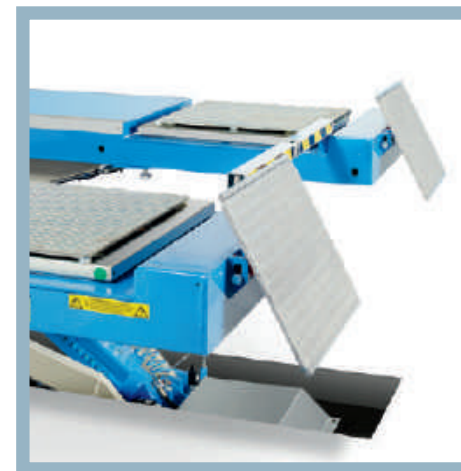

### ART. 856 PULSANTIERA DI COMANDO PROVAGIOCHI WIRELESS



Wireless remote control for play detectors

Platine de commandes pour plaque à jeux sans fil

Wireless-fernsteuerung für gelenkspieltester



Fornibile solo in fase costruttiva • Embedded accessory. Cannot be ordered separately

A commander avec le pont. Ne peut être fourni séparément • Nur mit der Bühne bestellbar. Nicht nachrüstbar

#### PULSANTIERA DI COMANDO PROVAGIOCHI WIRELESS

La pulsantiera è dotata di un innovativo sistema di attivazione piezoelettrica il quale permette di poter sempre e in ogni caso attivare il provagiochi anche a batteria completamente scarica! Lo stesso sistema è poi equipaggiato di lampada a led con accensione a movimento e viene fornito di tappetino ad induzione per la ricarica della batteria, necessaria per il solo funzionamento della lampada a led. Con questo strumento sarà più facile e più sicuro controllare i giochi dei mezzi e muoversi attorno ai veicoli senza lo spiacevole ingombro del cavo elettrico.

#### WIRELESS REMOTE CONTROL FOR PLAY DETECTORS

The remote control works through piezoelectric system, which allows the activation of the play detector in every moment, even when the battery is completely discharged! This item is also equipped with a LED lamp with a movement sensor and an induction mat to charge the battery, which is dedicated to the LED lamp only. Checking vehicle plays has never been so easy and secure, and you can move around the lift without bothering about cables.

#### PLATINE DE COMMANDES POUR PLAQUE À JEUX SANS FIL

La platine fonctionne sur un système innovant d'activation piézoélectrique qui permet d'actionner les plaques à jeux même quand les batteries sont complètement à plat! Dotée de lampe à led avec détecteur de mouvement et d'un tapis à induction pour recharger la batterie, uniquement consacrée à la lampe à led. Un outil qui facilite le contrôle des jeux en toute sécurité, et qui consent de se déplacer en toute liberté autour du véhicule sans s'empêtrer dans les câbles.

#### WIRELESS-FERNSTEUERUNG FÜR GELENK- SPIELTESTER

Die Fernsteuerung ist mit einem innovativen System zur piezoelektrischen Aktivierung ausgestattet, das es ermöglicht, den Gelenkspieltester jederzeit und unter allen Bedingungen zu aktivieren, auch bei völlig entladener Batterie! Das gleiche System verfügt außerdem über eine LED-Lampe mit Bewegungssensor und wird mit einer Induktionsmatte zum Aufladen der Batterie geliefert, die nur für die Funktion der LED-Lampe notwendig ist. Mit diesem Gerät ist es einfacher und sicherer, die Spiele zu kontrollieren und sich um die Fahrzeuge herum zu bewegen, ohne vom Stromkabel behindert zu werden.

**XLINE**<sup>®</sup>

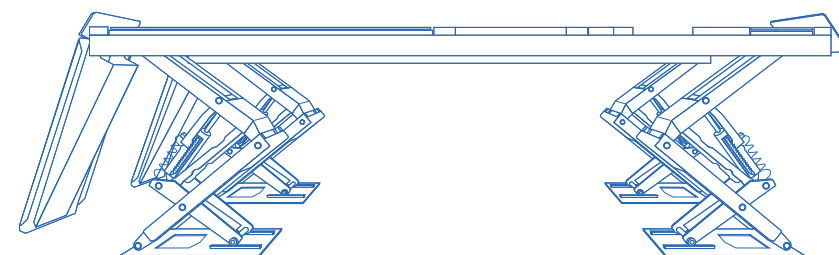

**PONTI SOLLEVATORI  
ELETTOIDRAULICI SERIE X-LINE**

ELECTROHYDRAULIC X-LINE LIFTS  
PONTS ELEVATEURS ELECTROHYDRAULIQUES X-LINE  
ELEKTROHYDRAULISCHE HEBEBÜHNEN X-LINE

Made in Italy 





# PONTI SOLLEVATORI ELETTROIDRAULICI SERIE X-LINE ELECTROHYDRAULIC X-LINE LIFTS

## TRACCIATO TECNICO

- Funzionamento elettroidraulico dotato di valvole di sicurezza, controllo velocità di discesa, sovraccarico e rotture accidentali dei tubi di alimentazione.
- Dispositivo meccanico ad inserimento automatico presente su entrambe le pedane per garantire la massima sicurezza.
- Parallelismo idraulico volumetrico con sistema elettronico dotato di PLC ed encoder.
- Base di appoggio a terra per la massima stabilità e planarità in fase di installazione e utilizzo.
- Massima praticità di lavoro grazie allo spazio di manovra completamente libero al di sotto ed attorno al sollevatore.
- Disponibile in configurazioni con pedana piana non accessoriata, per assetto ruote, oppure con prova-giochi.
- Perna con bocche in bronzo autolubrificanti.
- Modelli a pavimento ed a incasso.
- Olio per circuito idraulico in dotazione.
- Tasselli di ancoraggio al suolo in dotazione

## TECHNICAL SPECIFICATIONS

- Electro-hydraulic functioning with safety valves to control the descent speed, the overload and any accidental breakage of the feeding hoses.
- Mechanical rack device on both footboards to ensure maximum safety.
- Hydraulic volumetric parallelism with electronic system, equipped with PLC and encoder.
- Support base on the ground for the best stability and flatness during installation and use.
- Wide and completely free operational room under the lift.
- Possibility to configure the footboard during construction phase thanks to its modular system; in its plain version, for total alignment or equipped with play-detector.
- Pins with self-lubricating bronze bushes.
- Surface mounted and flush models.
- Delivered with oil for the hydraulic circuit.
- Delivered with anchor bolts.

# PONTS ELEVATEURS ELECTROHYDRAULIQUES X-LINE ELEKTROHYDRAULISCHE HEBEBÜHNEN X-LINE

## RELEVÉ TECHNIQUE

- Système électrohydraulique avec soupape de sécurité, contrôle système de descente, surcharge et ruptures accidentelles des tuyaux d'alimentation.
- Dispositif mécanique à insertion automatique sur les deux chemins de roulement pour une sécurité maximum.
- Parallélisme hydraulique volumétrique par système électronique avec automate et encoder.
- Base d'appui au sol pour une stabilité et une horizontalité optimales au montage et à l'utilisation.
- Passage libre sous le pont pour un espace de travail libéré de tout obstacle.
- Système modulaire sur les rampes, configurable en phase de construction du pont pour une version lisse, géométrie ou avec plaques à jeux.
- Axes avec bagues en bronze autolubrifiantes.
- Versions posées au sol et encastrés.
- Huile pour circuit hydraulique fournie.
- Chevilles d'ancrage au sol fournies.

## TECHNISCHE ANGABEN

- Elektrohydraulische Funktion mit Sicherheitsventilen zur Kontrolle der Absenkgeschwindigkeit, der Überlastung und zur Überwachung der Druckleitungen.
- Automatische mechanische Verriegelungsvorrichtung an beiden Fahrschienen um die maximale Sicherheit zu gewährleisten.
- Elektronisches Überwachungssystem ausgestattet mit PLC und Encoder der volumetrischen hydraulischen Gleichlaufregelung.
- Bodenplatte, um maximale Stabilität und Ebenheit während des Einbaus und Benutzung zu gewährleisten.
- Viel Freiraum und Platz zum Arbeiten unter und neben der Hebebühne.
- Wahlweise ab Werk lieferbar mit flachen Fahrschienen (ohne Zubehör), mit Ausstattung zur Achsvermessung oder mit Gelenkspieltester.
- Selbstschmierende Bolzen in Bronze-Buchsen.
- Überflur- und Unterflur Modelle verfügbar.
- Wird komplett mit Öl für die hydraulische Anlage geliefert.
- Wird komplett mit Bodenankerbolzen geliefert.





**XLINE**

**5500 KG**



ART. 863 **OPTIONAL** Pag. 094

## MODELLI A PEDANE PIANE

Models with flat platforms  
 Modeles avec chemins de roulement nus  
 Modelle mit flachen fahrschienen

860 • 860/I • 864 • 864/I

## MODELLI PER ASSETTO RUOTE

Wheel alignment models  
 Modeles pour geometrie roues  
 Modelle geeignet zur achsvermessung

861 • 861/I • 862 • 862/I

## MODELLI PER ASSETTO CON PROVAGIOCHI

Alignment models with play detector  
 Modeles pour geometrie avec plaques a jeux  
 Achsmessmodelle mit gelenkspieltestern

863 • 863/I

## MODELLI CON PROVAGIOCHI

Models with play detector  
 Modeles avec plaques a jeux  
 Modelle mit gelenkspieltestern

865 • 865/I • 866 • 866/I

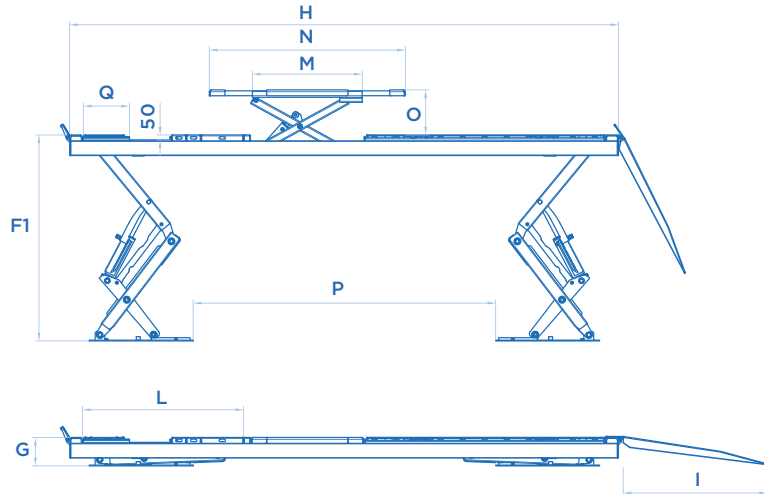

CE Made in Italy 

Versione a pavimento • Floored model • Modèle au sol • Überflur-Modell

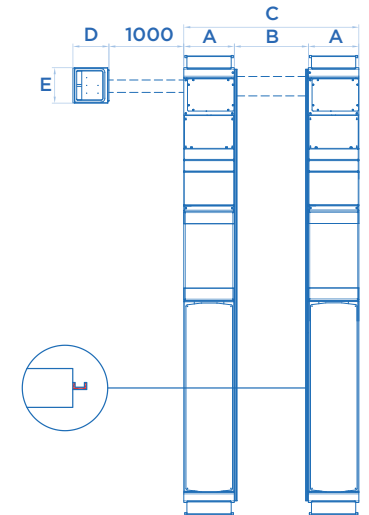
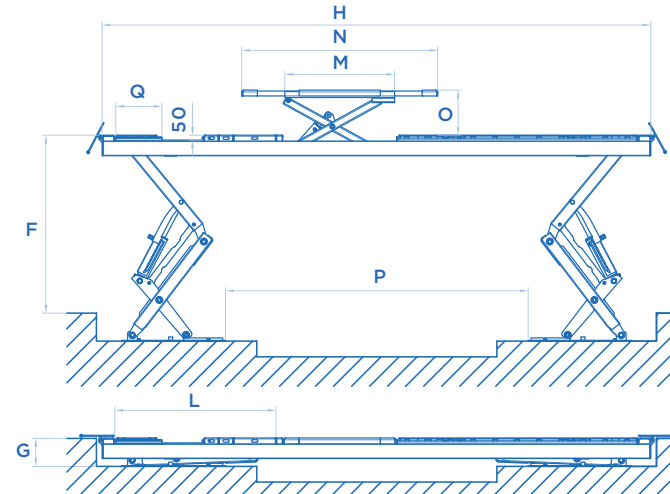

Versione a scomparsa • Disappearing model • Modèle encastrable • Unterflur-Modell



ART.			Motore trifase Three-phase motor Moteur triphasé Netzspannung	A <sub>mm</sub>	B <sub>mm</sub>	C <sub>mm</sub>	D <sub>mm</sub>	E <sub>mm</sub>	F <sub>mm</sub>	F <sub>1mm</sub>	G <sub>mm</sub>	H <sub>mm</sub>	I <sub>mm</sub>	L <sub>mm</sub>	M <sub>mm</sub>	N <sub>mm</sub>	O <sub>mm</sub>	P <sub>mm</sub>	Q <sub>mm</sub>	
860				650	900	2200	450	600	1800	1850	260	5600	1400					3000		2500
860/I				650	900	2200	450	600	1800	1850	260	5600						3000		2350
861				650	900	2200	450	600	1800	1850	300	5600	1600	1640				3000		2850
861/I				650	900	2200	450	600	1800	1850	300	5600		1640				3000		2700
862	4000Kg			650	900	2200	450	600	1800	1850	300	5600	1600	1640	1150	2100	440	3000		3190
862/I	4000Kg	4 kW	400V • 50HZ	650	900	2200	450	600	1800	1850	300	5600		1640	1150	2100	440	3000		3040
863	4000Kg			650	900	2200	450	600	1800	1850	300	5600	1600	1640	1150	2100	440	3000	470	3300
863/I	4000Kg			650	900	2200	450	600	1800	1850	300	5600		1640	1150	2100	440	3000	470	3150
864	4000Kg			650	900	2200	450	600	1800	1850	300	5600	1600		1150	2100	440	3000		2940
864/I	4000Kg			650	900	2200	450	600	1800	1850	300	5600			1150	2100	440	3000		2790
865	4000Kg			650	900	2200	450	600	1800	1850	300	5600	1600		1150	2100	440	3000	470	3130
865/I	4000Kg			650	900	2200	450	600	1800	1850	300	5600			1150	2100	440	3000	470	2980
866				650	900	2200	450	600	1800	1850	300	5600	1600					3000	470	2700
866/I				650	900	2200	450	600	1800	1850	300	5600						3000	470	2550

Sollevatori per linee di revisione B=800 mm



Potenza motore • Motor power • Puissance moteur • Motorleistung

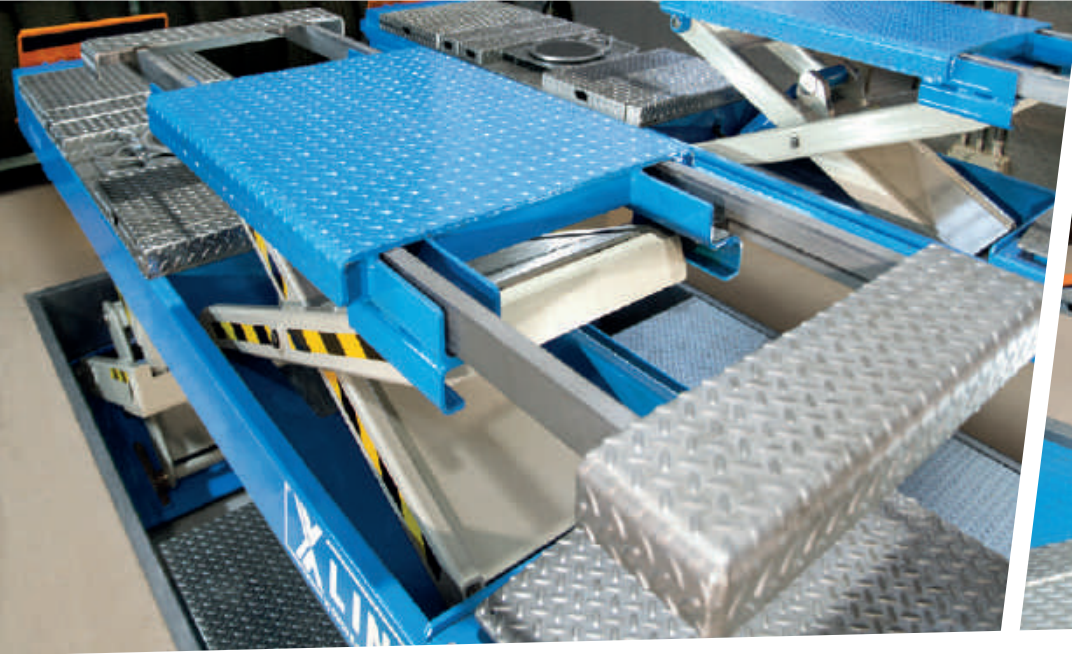

**LIFT TABLE DA 4.000 KG CON DOPPIE PROLUNGHE ANTERIORI E POSTERIORI PER SOLLEVARE DALLA SMART AL VEICOLO COMMERCIALE**

Lift table capacity 4.000 kg with front and rear extensions to lift from the Smart up to vans

Élévateur auxiliaire capacité 4000 kg avec rallonges antérieures et postérieures pour le levage de véhicules de la Smart jusqu'au fourgon

4 ton Zusatzhubplattform mit Doppelverlängerungen (vorne und hinten), um vom Smart bis zum Lieferwagen alles heben zu können.

**TUTTI I MODELLI SONO DOTATI DI GUIDE PER LO SCORRIMENTO DI TRVERSE DI SOLLEVAMENTO**

All models are equipped with guideways for jacking beams

Tous les modèles sont équipés de guides pour traverses de levage de série

Alle Modelle sind mit Schienen für Achsfreiheber ausgestattet.





**QUATTRO BASI DI APPOGGIO A TERRA DI DIMENSIONI CONTENUTE ASSICURANO MAGGIOR STABILITÀ DELLA STRUTTURA E FACILITÀ DI INSTALLAZIONE**

Four ground support bases of limited dimensions to assure better stability and ease of installation

Quatre supports à terre de dimensions réduites assurent une grande stabilité à la structure et facilitent l'installation

4 Bodenplatten, für maximale Konstruktionsstabilität und für einen einfachen Einbau.

**IL DESIGN BREVETTATO UNISCE LA PRATICITÀ DI LAVORO DI UN SOLLEVATORE A 4 COLONNE CON L'INGOMBRO RIDOTTO DI UN MODELLO A FORBICE. TUTTA L'AREA SOTTO AL SOLLEVATORE È LIBERA DA INGOMBRI E ACCESSIBILE DA OGNI DIREZIONE**

The patented design combines the ease of use of a 4 - post lift with the reduced encumbrance of a scissor lift. The area under the lift is totally clear and accessible from every direction

Concept brevetée qui allie praticité du 4 colonnes et encombrement réduit du pont ciseaux. L'espace sous le pont est totalement libre et accessible dans toutes les directions

Das patentierte Design kombiniert die Einfachheit des Arbeitens mit einer 4-Säulen-Hebebühne mit reduziertem Raumbedarf einer Scheren-Hebebühne. Die gesamte Fläche unter der Hebebühne ist komplett frei und von allen Seiten begehbar.

**PIASTRE OSCILLANTI POSTERIORI BLOCCABILI TRAMITE COMANDO PNEUMATICO POSTO SULLA CENTRALE DI COMANDO (MODELLI PER ASSETTO RUOTE)**

Rear oscillating plates can be blocked by air control on the control unit (wheel alignment models)

Plaques de ripage arrière pouvant être bloquées par commande pneumatique sur le pupitre (modèles pour géométrie)

Pneumatische Verriegelung der hinteren Schiebeplatten auf dem Steuerpult (Modelle geeignet zur Achsvermessung)

**INCAVO ANTERIORE PER ALLOGGIAMENTO DEI PIATTI ROTANTI MODULARE E DI GRANDI DIMENSIONI (MODELLI PER ASSETTO RUOTE)**

Large and modular front slots to host rotating plates (wheel alignment models)

Logements avant pour plateaux tournants modulaires et de grandes dimensions (modèles pour géométrie)

Große und modulare vordere Aussparung für Drehteller (Modelle geeignet zur Achsvermessung)

**ALLINEAMENTO TRA LE DUE PEDANE ASSICURATO DA 4 SENSORI DI POSIZIONE AD ALTISSIMA RISOLUZIONE**

Footboard alignment granted by four high resolution position sensors

Alignement entre les rampes par 4 capteurs de position à très haute résolution

Synchronisierung der 2 Fahrschienen mit 4 Ortungssensoren in sehr hoher Auflösung.

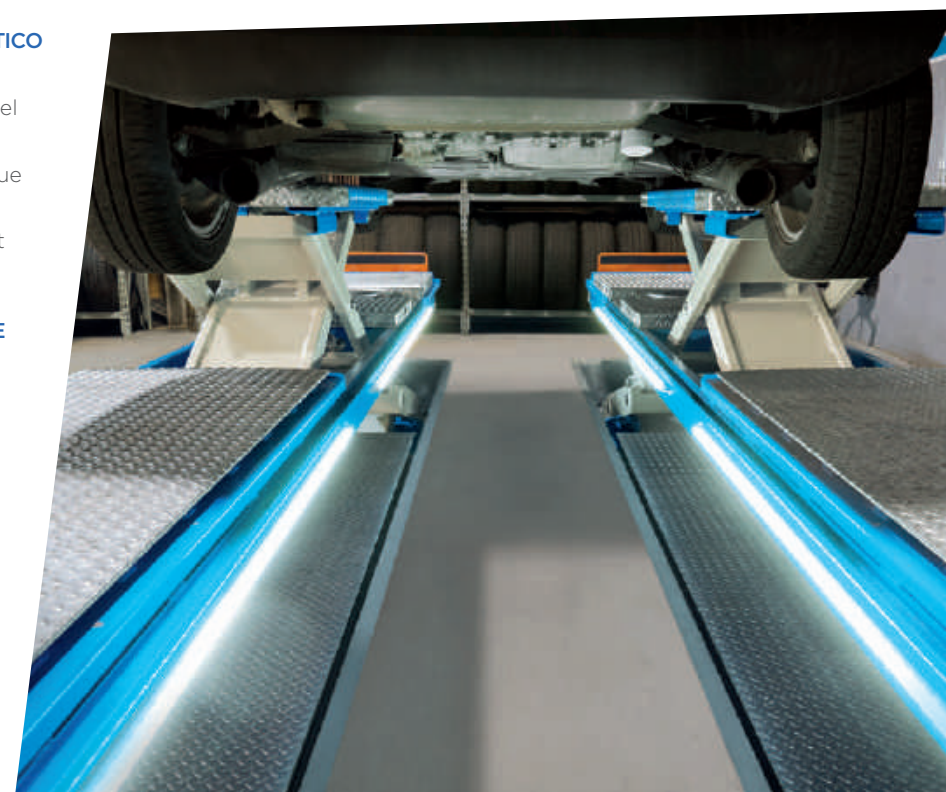

## ACCESSORI EXTRA DOTAZIONE

EXTRA EQUIPMENT • ACCESSOIRES EN OPTION • EXTRA ZUBEHÖR

**KIT**

**X4**

**ART.**

<b>715</b>	80
<b>715/A</b>	120
<b>715/B</b>	200
<b>715/C</b>	60
<b>715/D</b>	40
<b>715/E</b>	30



mm

**TAMPONI**  
 Tampons  
 Pads  
 Gummiauflagen



**ART. 845/A**  
**IMPIANTO**  
**DI ILLUMINAZIONE A LED**

Led lighting system  
 Kit d'éclairage led  
 LED Beleuchtungsanlage



**ART. 848**  
**SET DI TRAVERSE**

Pair of auxiliary traverses  
 Paire de traverses  
 Zusätzliche Quertraversen



1000 Kg X 2



**TELAI PER INCASSO**

Embedding frames  
 Caissons pour modèles encastrables  
 Metallrahmen für Grube

**ART. 847/E**  
 ✓ ART. 860/I

**ART. 847/F**  
 ✓ ART. 861/I • 862/I • 863/I • 864/I • 865/I • 866/I



**PROLUNGHE DI COLLEGAMENTO**  
**TRA IL SOLLEVATORE E LA**  
**CENTRALINA DI COMANDO (1 m)**

Connection extensions between the hoist and the control box  
 Rallonges de jonction entre l'élévateur et le pupitre de commande  
 Verlängerungsschläuche (zwischen Hebebühne und Steuerpult)

**ART. 852/C** ✓ ART. 860 • 860/I • 861 • 861/I  
**ART. 852/D** ✓ ART. 863 • 863/I • 865 • 865/I  
**ART. 852/E** ✓ ART. 862 • 862/I • 864 • 864/I • 866 • 866/I

**ART. 857**  
**KIT PEDANINE COPRIBUCA**  
**AUTOMATICHE**

Automatic footboards pit covering kit  
 Kit plate-formes automatiques couvre-fosse  
 Automatisch Farschinentensatz für Grubenabdeckung

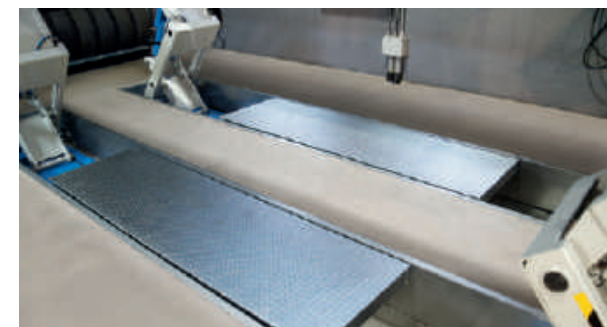
**ART. 856**  
**PULSANTIERA DI COMANDO**  
**PROVAGIOCHI WIRELESS**

Wireless remote control for play detectors  
 Platine de commandes pour plaque à jeux sans fil  
 Wireless-fernsteuerung für gelenkspieltester





**KIT**

**ART. PLUS**  
**MORSA DI BLOCCAGGIO RUOTA**  
**PER MOTOVEICOLI E PEDANINE**  
**SUPPLEMENTARI**

**ART.**

Modelli per linee di revisione

**PLUS** ✓

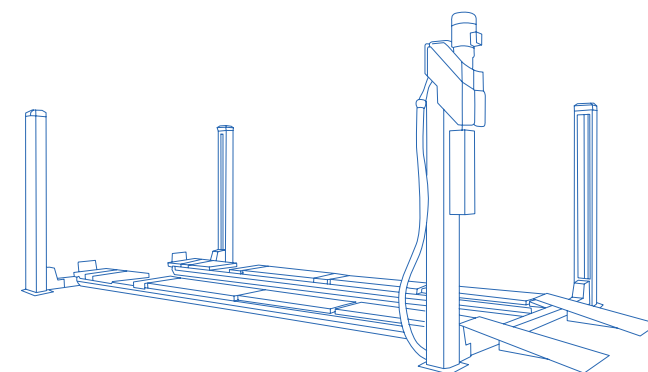

**PONTI SOLLEVATORI  
ELETTRIDRAULICI A 4 COLONNE**

ELECTROHYDRAULIC 4-POST LIFTS  
PONTIS ELEVATEURS A 4 COLONNES ELECTROHYDRAULIQUES  
ELEKTROHYDRAULISCHE 4-SÄULEN HEBEBÜHNEN

Made in Italy 





## PONTI SOLLEVATORI ELETTROIDRAULICI A 4 COLONNE ELECTROHYDRAULIC 4-POST LIFTS

### TRACCIATO TECNICO COSTRUTTIVO

- Sollevatori a funzionamento elettroidraulico a 4 colonne.
- Le loro strutture adeguatamente dimensionate, lo spazio utile interno e le dimensioni delle pedane consentono di sollevare anche veicoli di grandi dimensioni.
- Dispositivi di sicurezza bloccano il ponte in caso di rottura o di allentamento delle funi portanti.
- Pulegge in alluminio dotate di cuscinetti a sfera.
- **Livello di sicurezza a tre stadi: ancoraggi meccanici, breaking system sulla tensione funi, sicurezza elettrica supplementare.**
- Valvola di blocco in caso di avaria alla condotta idraulica e valvola di sicurezza per evitare di sollevare pesi superiori alla portata nominale.
- Impianto elettrico a 24 V.
- Tasselli di ancoraggio al suolo in dotazione.

### TECHNICAL AND STRUCTURAL LAY-OUT

- 4-post autolifts, electrohydraulic functioning.
- With specifically designed structures, the internal working space and the dimensions of the platforms make it possible to lift from small to large vehicles.
- Safety devices lock the autolift in case of slack and/or cable failure.
- Alumium pulley with ball bearing.
- **3-phases safety level: mechanical anchors on the rack, cable anti-breaking system and additional electric safety.**
- Safety valves both stop over capacity lifting and hydraulic failure.
- 24 V safety system.
- Equipped with anchor small blocks.



# PONTS ELEVATEURS A 4 COLONNES ELECTROHYDRAULIQUES

## ELEKTROHYDRAULISCHE 4-SÄULEN HEBEBÜHNEN

### RELEVÉ TECHNIQUE

- Elévateurs 4 colonnes à fonctionnement électro-hydraulique.
- Leurs structures parfaitement étudiées permettent, grâce à l'espace utile interne et aux dimensions des chemins de roulement, de lever des véhicules de petites et grandes tailles.
- Des dispositifs de sécurité bloquent le pont en cas de rupture ou de distension des câbles porteurs.
- Poulies en aluminium montées sur roulements à billes.
- **3 niveaux de sécurité: stationnement par ancrage mécanique, système de prévention rupture des câbles, sécurité électriques supplémentaire.**
- Soupape de blocage en cas d'avarie sur le conduit hydraulique et soupape limitative de charge pour empêcher le levage de poids supérieurs à la portée indiquée.
- Circuit électrique 24 V.
- Chevilles d'ancrage au sol fournies.

### TECHNISCHE UND KONSTRUKTIVE ANGABEN

- Elektrohydraulische 4-Säulen-Hebebühnen, einfach und sicher zu bedienen.
- Die durchdachte Konstruktion, die Abmessungen sowie die Verschiebbarkeit der Auffahrtschienen ermöglichen das Heben kleiner und großer Fahrzeuge.
- Sicherheitsvorrichtungen blockieren die Bühne bei Seilbruch oder einem Lockern der Seile.
- Aluminiumriemenscheiben mit Kugellager.
- **3-Stufig Sicherheitsniveau bestehend aus mechanische Zahnstange, System gegen den Bruch auf der Seilspannkraft und zusätzliche elektrische Sicherheit.**
- Beim Absenken entriegeln die Stützriegel automatisch.
- Rückschlagventil im Falle eines Versagens der Hydraulik sowie ein Sicherheitsventil, um eine Überlastung der Bühne- über die angegebene Tragkraft hinaus- zu verhindern.
- Steuerspannung 24 V.
- Ausgestattet mit schmaler Grundplatte.





# CLASSIC LINE

MODELLI A  
PEDANE PIANE  
MODELS WITH FLAT  
PLATFORMS  
MODELES AVEC CHEMINS  
DE ROULEMENT NUS  
MODELLE MIT FLACHEN  
FAHRSCHIENEN

3500  
4000  
4500 | **KG**



ART. 401

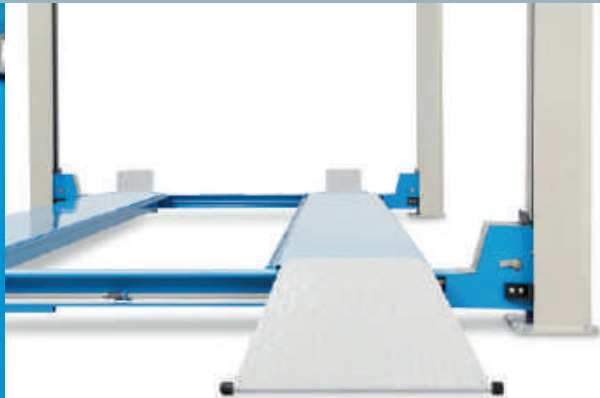
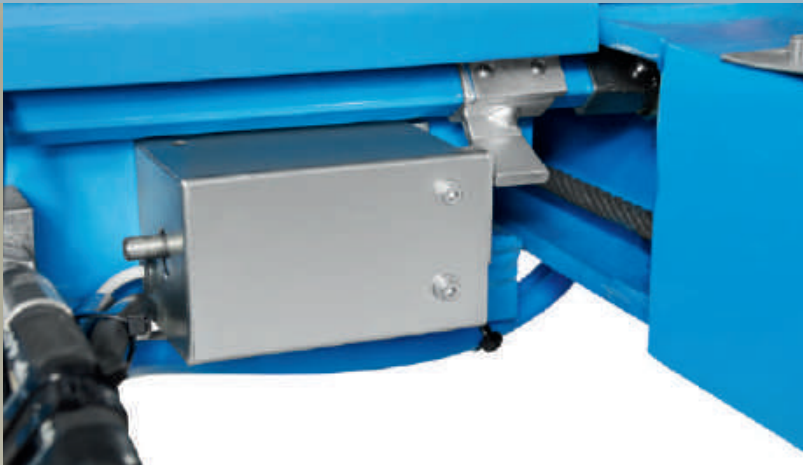
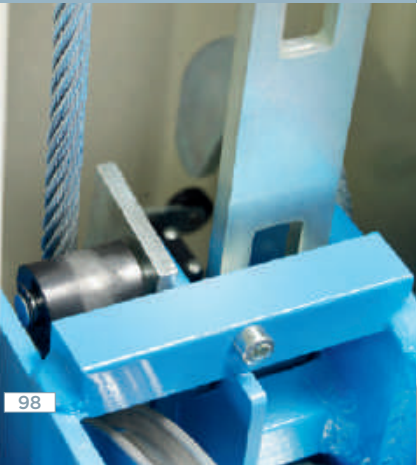

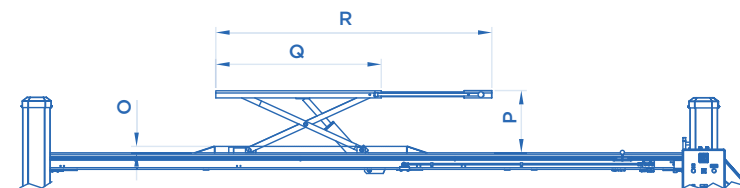
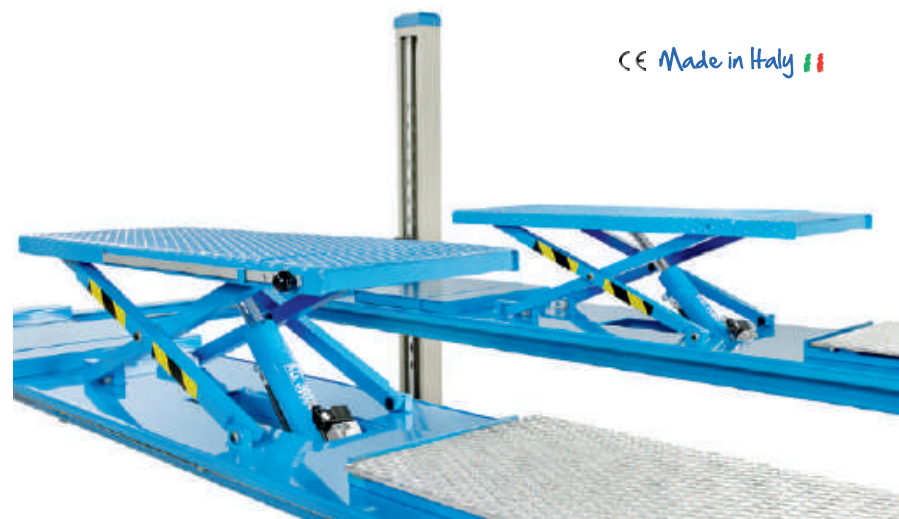
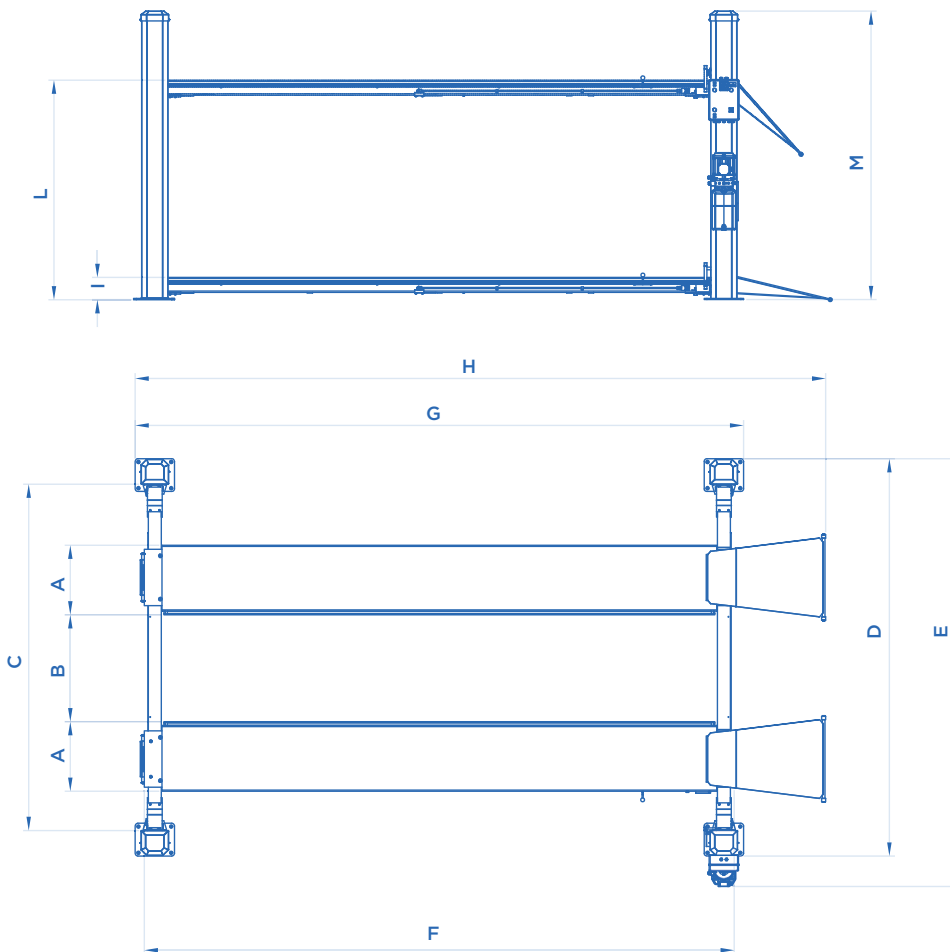

ART.	 LIFT TABLE	 O mm	 P mm	 Q mm	 R mm
401/I	3000 Kg	50	450	1400	2000

 Potenza motore • Motor power  
Puissance moteur • Motorleistung

**OPTIONAL** Pag. 106

ART.			Motore trifase Three-phase motor Moteur triphasé Netzspannung	 A mm	 B mm	 C mm	 D mm	 E mm	 F mm	 G mm	 H mm	 I mm	 L mm	 M mm	 KG		
<b>399</b>	3500 Kg	2,2 Kw	400V • 50HZ		MIN	MAX											
<b>400</b>																	
<b>400/L</b>																	
<b>401</b>	4000 Kg	3,3 Kw															
<b>401/I</b>																	
<b>401/L</b>																	
<b>401/LS</b>	4500 Kg																

**OMCN**  
S.p.A.



**MODELLI  
PER ASSETTO RUOTE  
WHEEL ALIGNMENT  
MODELS  
MODELES POUR  
GEOMETRIE ROUES  
MODELE GEEIGNET  
ZUR ACHSVERMESSUNG**

**3500  
4000 KG**

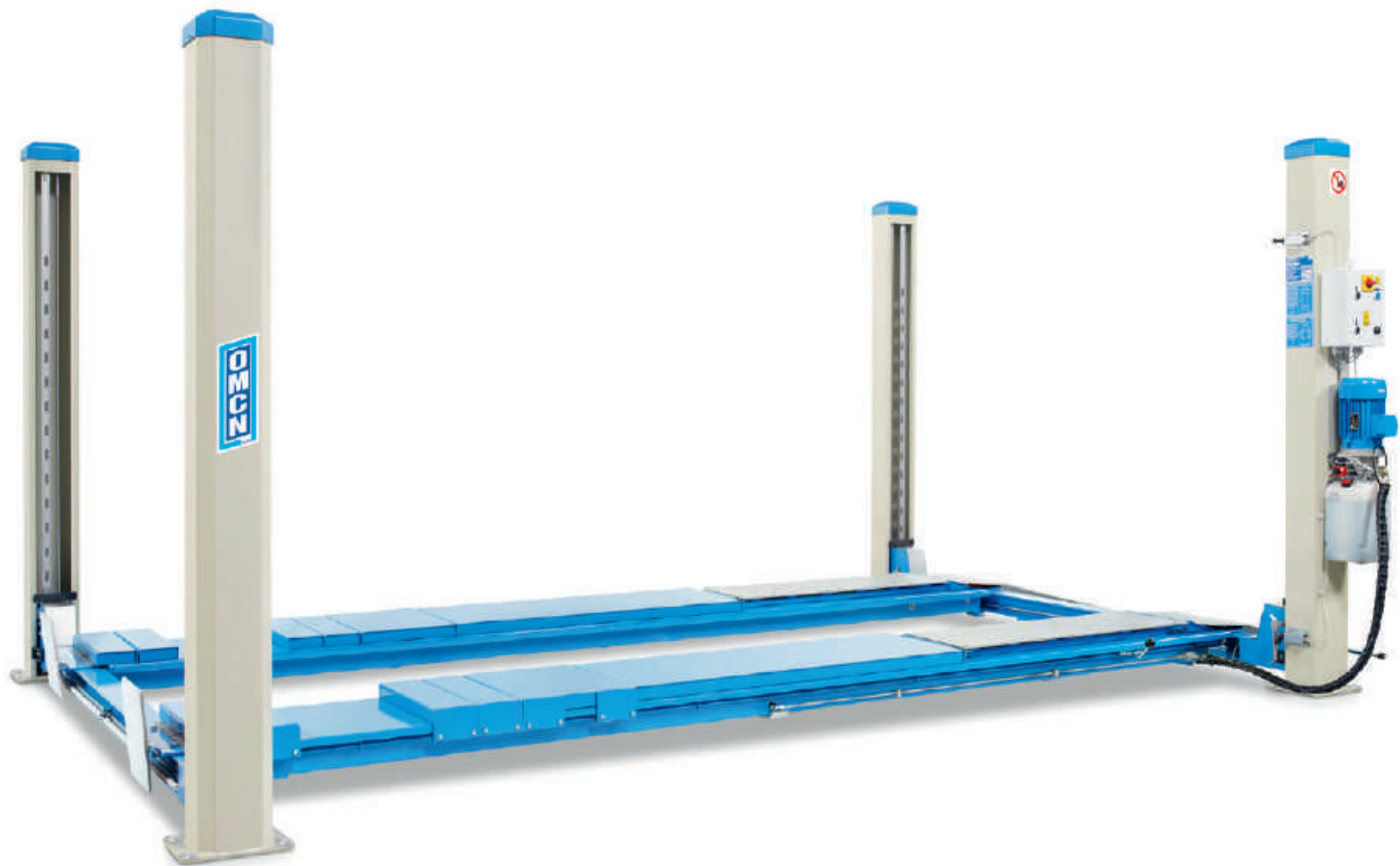

ART. 401/C

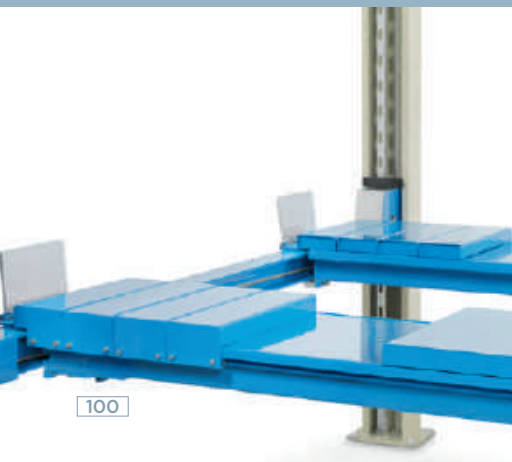

100

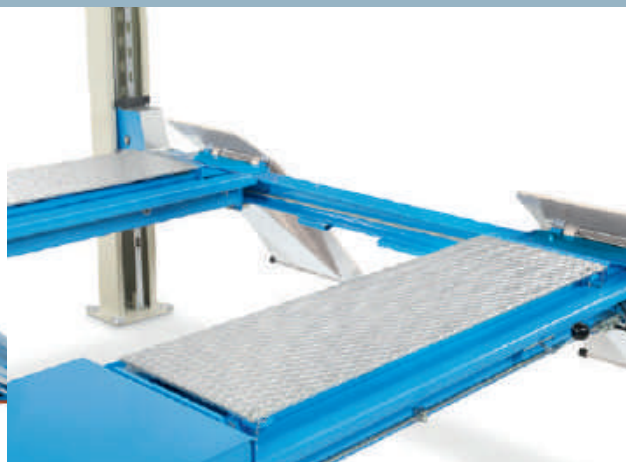

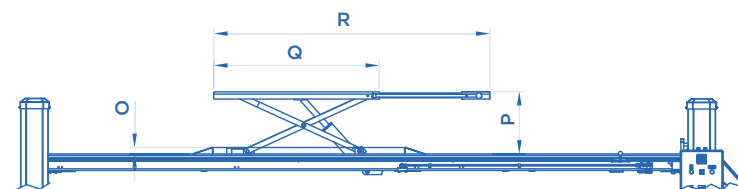
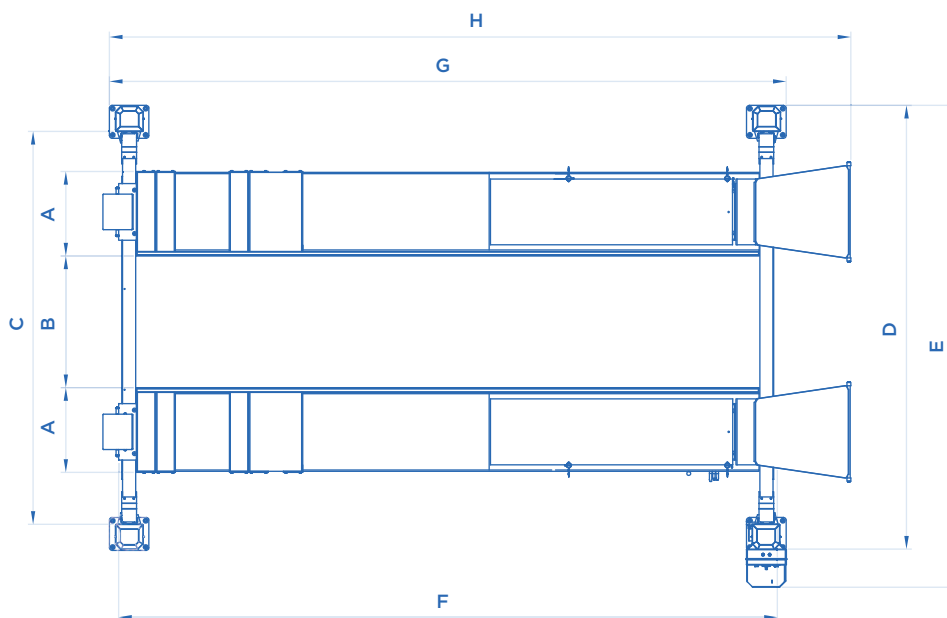
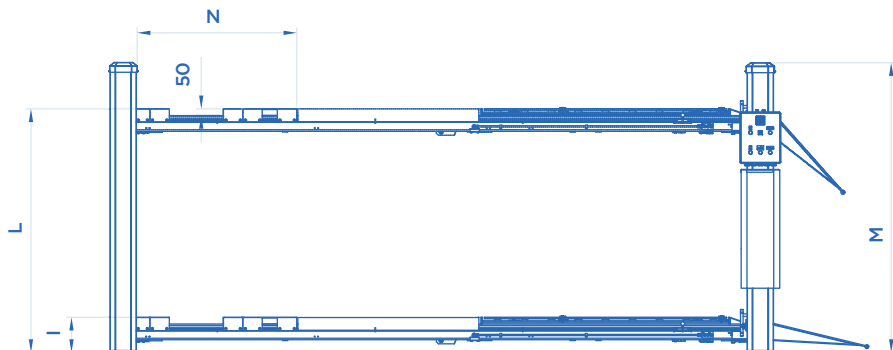













ART.					
401/CSAI	3000 Kg	0	400	1400	2000

 Potenza motore • Motor power  
Puissance moteur • Motorleistung

**OPTIONAL** Pag. 106

ART.			Motore trifase Three-phase motor Moteur triphasé Netzspannung													
400/C 402/L 401/C	3500 Kg	2,2 Kw	400V • 50HZ		MIN	MAX										
				500	820	1100	2650	3030	3300	<b>4500</b>	4640	5250	210	1850	2200	1400
600	720	1000		3000	3380	3650	<b>5000</b>	5140	5750	210	1850	2200	1900	1470		
500	820	1100		2650	3030	3300	<b>4500</b>	4640	5250	210	1850	2200	1400	1420		
500	820	1100		2650	3030	3300	<b>4500</b>	4640	5250	210	1750	2200	870	1890		
600	720	1000		3000	3380	3650	<b>5000</b>	5140	5750	210	1850	2200	1900	1650		
401/CSAI 402/LS	4000 Kg	3,3 Kw														



ART. 403/CSAI

#### TRACCIATO TECNICO COSTRUTTIVO

- **Dispositivo meccanico di stationamento con sblocco pneumatico e risalita automatica.**
- PLC gestionale con sistema di autodiagnosi integrato.
- Versione extra large con luce tra le colonne di 3000 mm.
- Guide per traverse zincate, sviluppate per evitare il ristagno di acqua.
- Quadro di comando di nuova generazione con motore rialzato e carter di copertura per ridurre gli ingombri attorno alle colonne.
- Doppie piastre oscillanti posteriori con movimentazione  $\pm 5^\circ$  (403/C - 403/CSAI).

#### TECHNICAL AND STRUCTURAL LAY-OUT

- **Mechanical stationing device with pneumatic unlock and automatic raising.**
- Microprocessor (PLC) with an auto-diagnosis embedded system.
- Extra-large version, 3000 mm between the columns.
- Galvanized rails for crosspieces conceived to avoid any water stagnation.
- New generation control box with an upper engine and a cart cover aiming to reduce the room occupied around the columns.
- Double oscillating rear plates with  $\pm 5^\circ$  movement (403/C - 403/CSAI).

#### RELEVÉ TECHNIQUE

- **Dispositif mécanique de stationnement à déverrouillage pneumatique et remontée automatique.**
- Automate (API) à autodiagnostic intégré.
- Version extra large, 3 mt entre les colonnes.
- Guides pour traverse galvanisées, spécialement conçues pour éviter que l'eau stagne.
- Boîtier de commandes de nouvelle génération avec moteur relevé et carter de protection pour un encombrement réduit autour de la colonne.
- 2 plaques de ripage arrière à mouvement  $\pm 5^\circ$  (403/C - 403/CSAI).

#### TECHNISCHE UND KONSTRUKTIVE ANGABEN

- **Mechanische Absperrvorrichtung mit pneumatischer Auslösung und automatischer Aufstieg.**
- PLC Mikroprozessor mit einer integrierten Vorrichtung für die automatische Diagnose.
- Extra Breitversion mit einer 3000 mm Öffnung zwischen den Säulen.
- Verzinkte Führungen für Achsfreiheber gegen die Wasserstauung.
- Neue Schalttafel mit einem erhobenen Motor und Motorgehäuse, um die Lagerfläche rundum den Säulen zu reduzieren.
- Hintere Doppelgleitplatten mit einer  $\pm 5^\circ$  Bewegung (403/C - 403/CSAI).

**MODELLI A PEDANE PIANE**  
**MODELS WITH FLAT PLATFORMS**  
**MODELES AVEC CHEMINS DE ROULEMENT NUS**  
**MODELLE MIT FLACHEN FAHRSCHIENEN**

**MODELLI PER ASSETTO RUOTE**  
**WHEEL ALIGNMENT MODELS**  
**MODELES POUR GEOMETRIE ROUES**  
**MODELLE GEEIGNET ZUR ACHSVERMESSUNG**

ART. 403 • 403/LS • 403/LSI

ART. 403/C • 403/CSAI

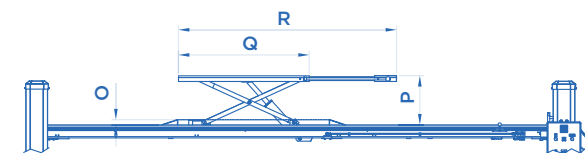
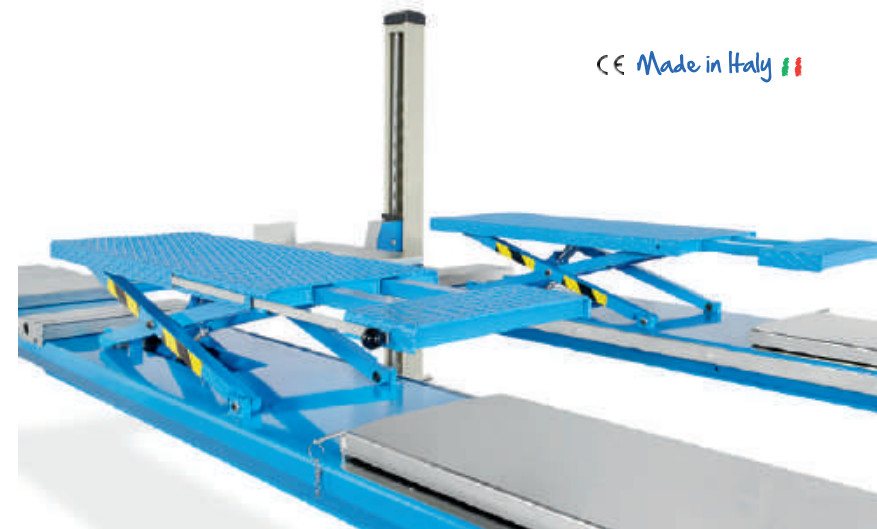
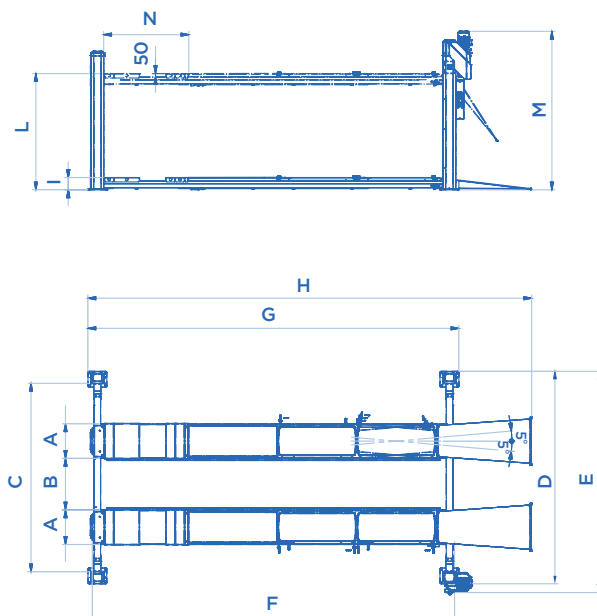
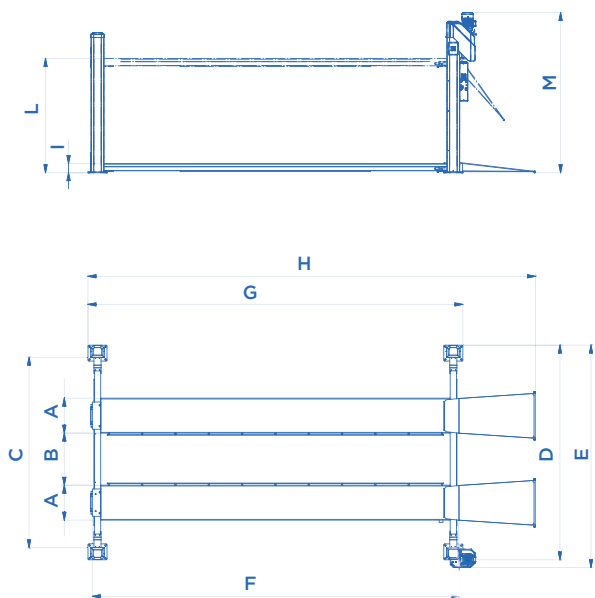

ART.	LIFT TABLE	O mm	P mm	Q mm	R mm
403/LSI	3500 Kg	50	450	1400	2000
403/CSAI		0	400	1400	2000

⚙️ Potenza motore • Motor power  
 Puissance moteur • Motorleistung

**OPTIONAL** Pag. 106

ART.	LIFT TABLE	⚙️	Motore trifase Three-phase motor Moteur triphasé Netzspannung	A mm	B mm	C mm	D mm	E mm	F mm	G mm	H mm	I mm	L mm	M mm	N mm	KG	
403	5000 Kg	⚙️	400V • 50HZ	550	MIN 820	MAX 1100	3000	3380	3520	<b>4770</b>	4900	5670	160	1800	2580	1400	
403/LS				550	820	1100	3000	3380	3520	<b>5770</b>	5900	6670	160	1800	2580	1500	
403/LSI				550	820	1100	3000	3380	3520	<b>5770</b>	5900	6670	160	1800	2580	1750	
403/C				550	820	1100	3000	3380	3520	<b>5770</b>	5900	6670	210	1850	2580	1400	1740
403/CSAI				550	820	1100	3000	3380	3520	<b>5770</b>	5900	6670	210	1850	2580	1400	1980



**PROVAGIOCHI  
PLAY DETECTOR  
PLAQUES A JEUX  
GELENKSPIEL-TESTVORRICHTUNG**



**ART. 441 • 442**  
**PROVAGIOCHI A 4 MOVIMENTI**  
4 movement play detector  
Plaques à jeux 4 mouvements  
4 Bewegungen Gelenkspieltester

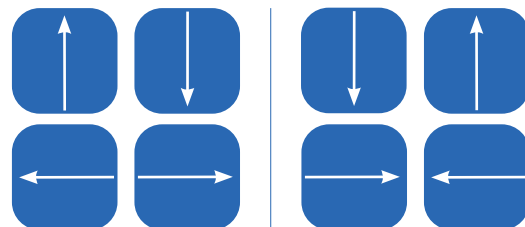

**ART. 441/A • 442/A**  
**PROVAGIOCHI A 8 MOVIMENTI**  
8 movement play detector  
Plaques à jeux 8 mouvements  
8 Bewegungen Gelenkspieltester

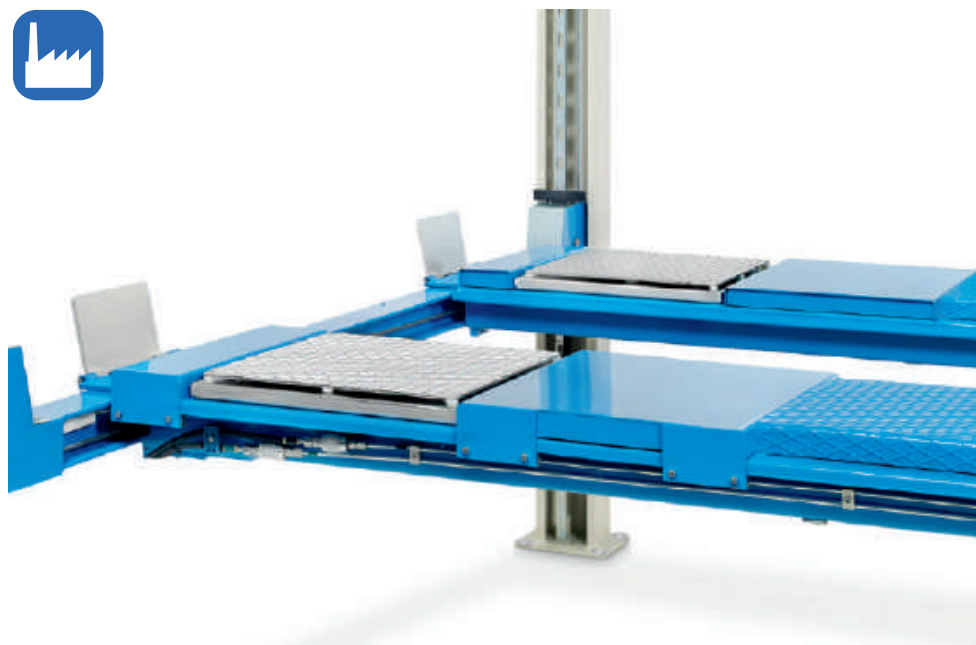

**ART. 441 • 441/A**  
**PROVAGIOCHI ELETTROIDRAULICO INSTALLATO SULLE PEDANE**  
ELECTRO-HYDRAULIC PLAY DETECTOR INSTALLED ON THE FOOTBOARDS  
PLAQUES À JEUX ÉLECTROHYDRAULIQUE MONTÉES SUR LES CHEMINS DE ROULEMENT  
ELEKTROHYDRAULISCHE GELENKSPIEL-TESTVORRICHTUNG, DIE AUF DIE  
FAHRSCHIENEN MONTIERT IST



**ART. 442 • 442/A**  
**PROVAGIOCHI ELETTROIDRAULICO INSTALLATO SU APPOSITE PROLUNGHE**  
ELECTRO-HYDRAULIC PLAY DETECTOR INSTALLED ON DEDICATED EXTENSIONS  
PLAQUE À JEUX ÉLECTROHYDRAULIQUE MONTÉES SUR LES RALLONGES APPROPRIÉES  
ELEKTROHYDRAULISCHE GELENKSPIEL-TESTVORRICHTUNG, DIE AUF BESTIMMTEN  
VERLÄNGERUNGEN MONTIERT IST

**ACCESSORI EXTRA DOTAZIONE**

EXTRA EQUIPMENT • ACCESSOIRES EN OPTION • EXTRA ZUBEHÖR

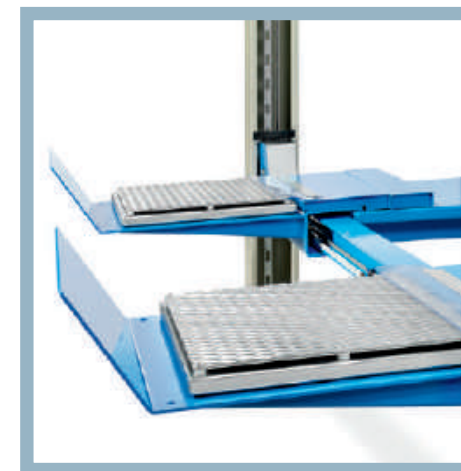
**PULSANTIERA DI COMANDO PROVAGIOCHI WIRELESS**

Wireless remote control for play detectors

Platine de commandes pour plaque à jeux sans fil

Wireless-fernsteuerung für gelenkspieltester

**ART. 856** ✓ ART. 441 • 442**ART. 856/A** ✓ ART. 441/A • 442/A**PULSANTIERA DI COMANDO PROVAGIOCHI WIRELESS**

La pulsantiera è dotata di un innovativo sistema di attivazione piezoelettrica il quale permette di poter sempre e in ogni caso attivare il provagiochi anche a batteria completamente scarica! Lo stesso sistema è poi equipaggiato di lampada a led con accensione a movimento e viene fornito di tappetino ad induzione per la ricarica della batteria, necessaria per il solo funzionamento della lampada a led. Con questo strumento sarà più facile e più sicuro controllare i giochi dei mezzi e muoversi attorno ai veicoli senza lo spiacevole ingombro del cavo elettrico.

**WIRELESS REMOTE CONTROL FOR PLAY DETECTORS**

The remote control works through piezoelectric system, which allows the activation of the play detector in every moment, even when the battery is completely discharged! This item is also equipped with a LED lamp with a movement sensor and an induction mat to charge the battery, which is dedicated to the LED lamp only. Checking vehicle plays has never been so easy and secure, and you can move around the lift without bothering about cables.

**PLATINE DE COMMANDES POUR PLAQUE À JEUX SANS FIL**

La platine fonctionne sur un système innovant d'activation piézoélectrique qui permet d'actionner les plaques à jeux même quand les batteries sont complètement à plat! Dotée de lampe à led avec détecteur de mouvement et d'un tapis à induction pour recharger la batterie, uniquement consacrée à la lampe à led. Un outil qui facilite le contrôle des jeux en toute sécurité, et qui consent de se déplacer en toute liberté autour du véhicule sans s'empêtrer dans les câbles.

**WIRELESS-FERNSTEUERUNG FÜR GELENK-SPIELTESTER**

Die Fernsteuerung ist mit einem innovativen System zur piezoelektrischen Aktivierung ausgestattet, das es ermöglicht, den Gelenkspieltester jederzeit und unter allen Bedingungen zu aktivieren, auch bei völlig entladener Batterie! Das gleiche System verfügt außerdem über eine LED-Lampe mit Bewegungssensor und wird mit einer Induktionsmatte zum Aufladen der Batterie geliefert, die nur für die Funktion der LED-Lampe notwendig ist. Mit diesem Gerät ist es einfacher und sicherer, die Spiele zu kontrollieren und sich um die Fahrzeuge herum zu bewegen, ohne vom Stromkabel behindert zu werden.

## ACCESSORI EXTRA DOTAZIONE

EXTRA EQUIPMENT • ACCESSOIRES EN OPTION • EXTRA ZUBEHÖR

### IMPIANTO DI ILLUMINAZIONE A LED



Led lighting system  
Kit d'éclairage led  
LED Beleuchtungsanlage

#### ART. 453

✓ F = 4200 • 4500 • 4770 • 5000 mm

#### ART. 453/A

✓ F = 5770 mm



KIT

X2

### SERIE PEDANINE SALITA E DISCESA PER LA PARTE ANTERIORE

Extra drive through up and down twin ramps for front side  
Jeu de rampes d'accès pour montée et descente pour la partie antérieure  
2 Auffahrschienen (vorne)

ART.



mm

454

800

454/A

1200



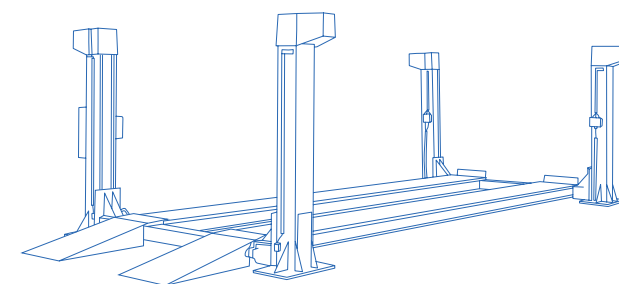

**PONTI SOLLEVATORI ELETTROMECCANICI  
A 4 COLONNE PER VEICOLI INDUSTRIALI**

ELECTROMECHANICAL 4-POST LIFTS FOR HEAVY VEHICLES  
PONTIS ELEVATEURS ELECTROMECHANIQUES 4 COLONNES POUR POIDS LOURDS  
ELEKTROMECHANISCHE 4-SÄULEN HEBEBÜHNEN FÜR SCHWERE FAHRZEUGE

Made in Italy 

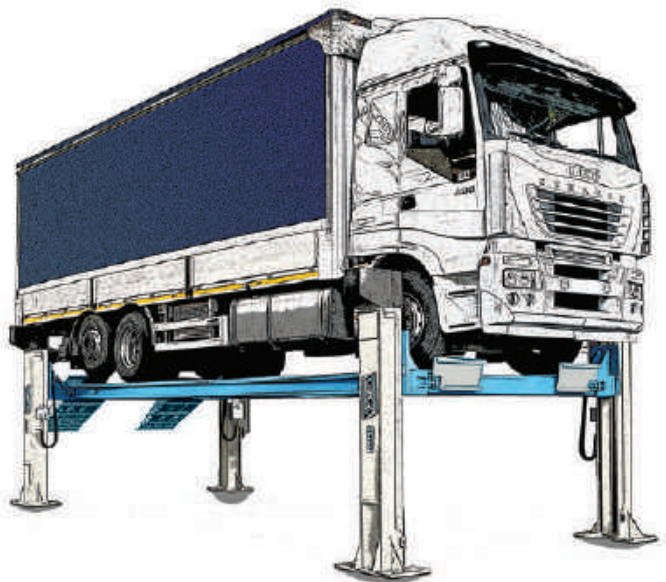

## PONTI SOLLEVATORI ELETTROMECCANICI A 4 COLONNE PER VEICOLI INDUSTRIALI

### ELECTROMECHANICAL 4-POST LIFTS FOR HEAVY VEHICLES

#### TRACCIATO TECNICO COSTRUTTIVO

- Funzionamento elettromeccanico.
- Sollevamento a mezzo di viti trapezoidali rullate, in acciaio ad alta resistenza, a passo fine per rendere autofrenanti i carrelli.
- Chiocciola portante in bronzo abbinata ad una seconda chiocciola di sicurezza di pari altezza e pari qualità di materiale, autoprotetta da sicurezza elettrica.
- Carrelli a scorrimento interno, completamente protetti.
- **Guide di scorrimento in acciaio trafilato pieno ad alta resistenza.**
- 6 ruote di grosso diametro in acciaio ad alta resistenza per ogni carrello, garantiscono una perfetta aderenza e scorrevolezza.
- Lubrificazione delle viti assicurata da un sistema montato direttamente sulla chiocciola portante.
- **Sincronizzazione fra i quattro carrelli controllata da un PLC gestionale, che comanda il riallineamento in presenza di una differenza superiore ai 15 mm.**
- Pedane di grosse dimensioni, di cui una regolabile trasversalmente.
- Motori elettrici sovradimensionati di primaria ditta costruttrice.
- Trasformatore generale a 24 V, componentistica elettrica di primaria scelta, impianto generale autoprotetto per garantire l'assoluta efficienza di tutte le sicurezze. Comando "uomo presente".
- Verniciatura a polvere epossidica di tutte le parti maggiormente esposte.
- Tasselli di ancoraggio al suolo in dotazione.

#### TECHNICAL AND STRUCTURAL LAY-OUT

- Electromechanic functioning.
- Lifting through trapezoidal turning screws, made of high resistance steel with fine pitch so that trolleys may become self-braking.
- Bronze bearing female nut together with a second safety female nut of the same height and of the same top material quality, self-protected by electrical safety.
- Completely protected internal sliding trolleys.
- **Slides in full drawn solid steel at high resistance.**
- 6 wheels with big diameter and in high-resistance steel for each trolley guarantee a perfect adhesion an flowability.
- Lubrification of the screw assured by a device mounted directly on the bearing nut.
- **Synchronization between the four trolleys regulated by an operational PLC which controls the realignment in presence of a difference of more than 15 mm.**
- Footboards of big dimensions, of which one transversally adjustable.
- Electric engines of top-building factory delivering more power.
- 24 V general transformer, top-choice electric components, self-protected general plant in order to guarantee the total efficiency of all the safety measures, "man standing-by" command.
- Epoxy powder painting of all mostly exposed parts.
- Equipped with anchor small blocks.

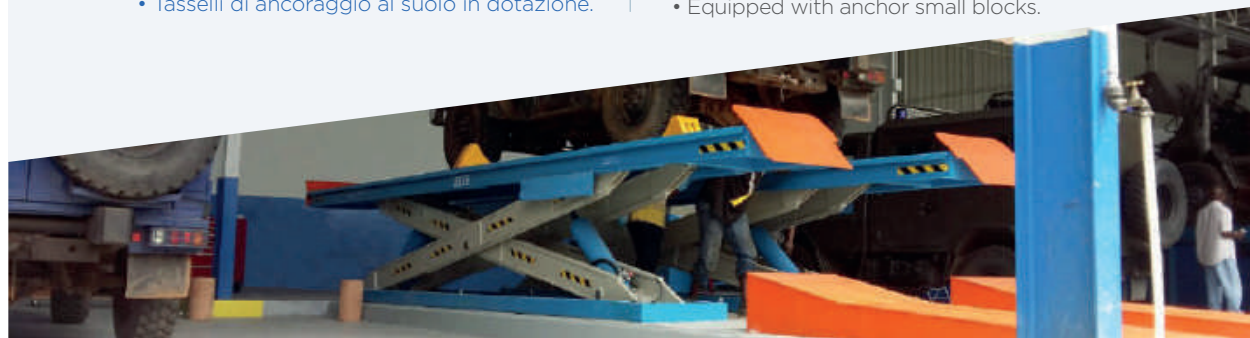

# PONTS ELEVATEURS ELECTROMECHANIQUES 4 COLONNES POUR POIDS LOURDS ELEKTROMECHANISCHE 4-SÄULEN HEBEBÜHNEN FÜR SCHWERE FAHRZEUGE

## RELEVÉ TECHNIQUE

- Fonctionnement électromécanique.
- Levage par vis trapézoïdales comprimées, en acier haute résistance. Pas de vis fin pour des chariots auto freinants.
- Erouc porteur en bronze couplé à un second écrou de sécurité identique au premier, autoprotégé par sécurité électrique.
- Chariots internes coulissants entièrement protégés.
- **Guides coulissants en acier trempé plein haute résistance.**
- Chariots montés sur 6 roues de grand diamètre en acier haute résistance pour une adhérence et un déplacement parfait.
- Lubrification des vis assuré par un système monté directement sur les écrous porteurs.
- **Synchronisme des 4 chariots contrôlé par PLC de gestion qui ordonne la remise à niveau si un décalage de plus de 15 mm est détecté.**
- Chemins de roulement de grande dimension, dont un réglable sur la largeur du pont.
- Moteurs électriques de haute qualité.
- Transformateur général 24 V, composants électriques de premier choix, équipement général auto protégé afin de garantir l'efficacité de toutes les sécurités, commande de type "homme mort".
- Peinture époxy sur les parties les plus exposées.
- Chevilles d'ancrage au sol fournies.

## TECHNISCHE UND KONSTRUKTIVE ANGABEN

- Elektromechanische Funktion.
- Hub erfolgt mittels Trapezgewindespindeln aus Spezialstahl.
- Abbremsen der Hubschlitzen erfolgt durch selbstbremsende Spindelgewinde.
- 2 identische Tragmuttern aus Lagerbronze (Typ B14), einmal als Sicherheitsmutter ausgeführt.
- Elektrische Sicherheitsabschaltung bei Tragmutter Schaden.
- Komplet geschützte, innenliegende Führungen.
- **Gleitbahnen aus gehärtetem, hochfestem Stahl.**
- 6 Räder mit großem Durchmesser und aus hochfestem Stahl gefertigt, garantieren eine gute Haftung sowie hervorragende Laufeigenschaften.
- Die Schmierung der Mutter erfolgt durch eine spezielle, direkt auf der Tragmutter installierte Schmiervorrichtung.
- **Automatische, elektronisch gesteuerte Synchronisation der 4 Hubschlitzen bei einem Höhenunterschied > 15 mm.**
- Große Fahrsschienen (1 x fest installiert, 1 x in der Breite verschiebbar).
- Leistungsstarker Elektromotor eines führenden Herstellers.
- 24 V- Haupttransformator, elektrische Bauteile namhafter Hersteller, Einhaltung sämtlicher Sicherheitsvorschriften 2-Hand-Steuerung.
- Epoxid-Pulverbeschichtung aller stark beanspruchten Teile.
- Ausgestattet mit schmaler Grundplatte.





**7**  
TON

**12**  
TON

**20**  
TON



ART. 407



ART. 405



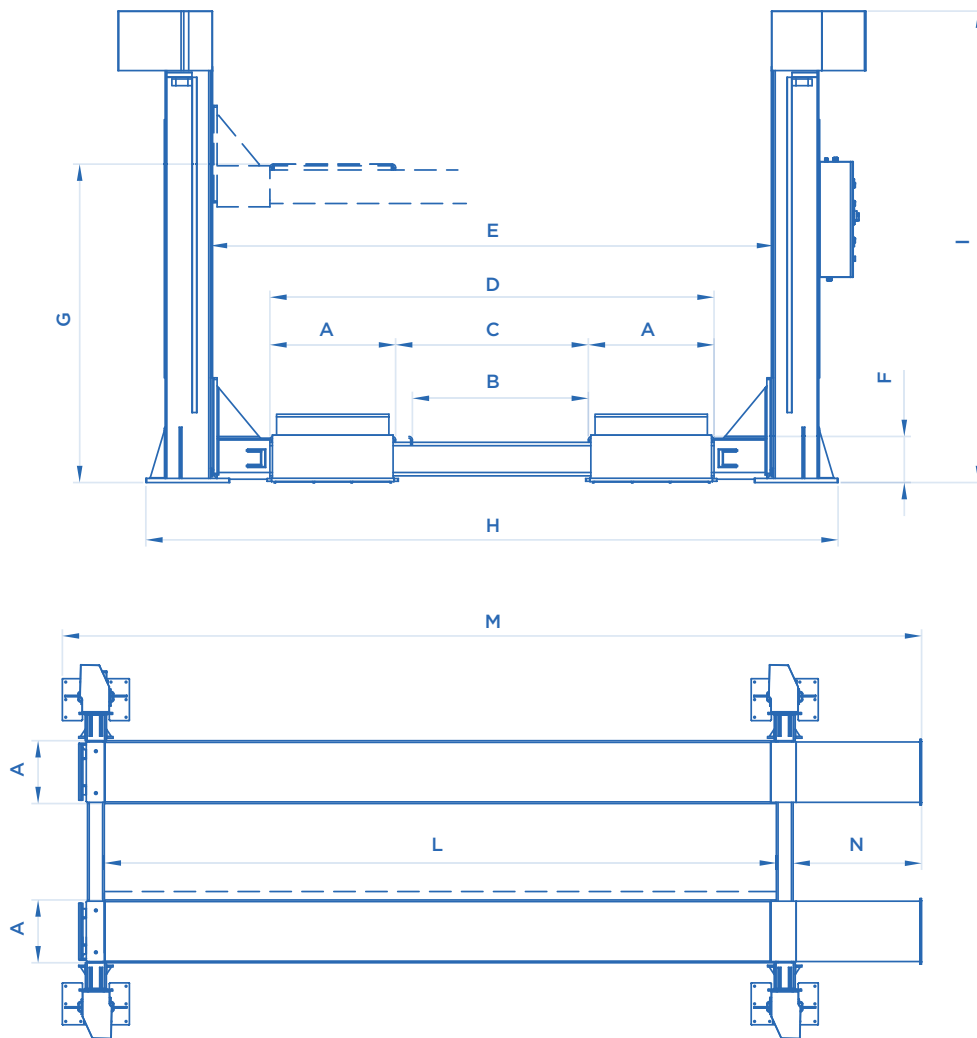

## ACCESSORI EXTRA DOTAZIONE

EXTRA EQUIPMENT • ACCESSOIRES EN OPTION • EXTRA ZUBEHÖR

### IMPIANTO DI ILLUMINAZIONE A LED

Led lighting system  
Kit d'éclairage led  
LED Beleuchtungsanlage



- ART. 453/A ✓ ART. 405
- ART. 453/B ✓ ART. 406 • 407



ART.			Motore trifase Three-phase motor Moteur triphasé Netzspannung	A mm	B mm	C mm	D mm	E mm	F mm	G mm	H mm	I mm	L mm	M mm	N mm	
405	7000 Kg	4x2,6 KW		650	850	1150	2450	3200	175	1920	3760	2575	5570	7000	1000	2500
406	12000 Kg	4x4 KW	400V • 50HZ	700	1100	1200	2600	3300	235	1920	4000	2610	8000	9950	1000	3700
407	20000 Kg	4x2,6 KW		750	1050	1150	2650	3360	275	1900	4150	2800	8000	10250	1500	6100

 Potenza motore • Motor power • Puissance moteur • Motorleistung

 Fornibile solo in fase costruttiva • Embedded accessory. Cannot be ordered separately • A commander avec le pont. Ne peut être fourni séparément • Nur mit der Bühne bestellbar. Nicht nachrüstbar

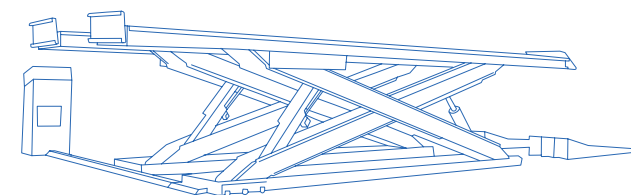

## **PONTI SOLLEVATORI ELETTROIDRAULICI A FORBICE PER VEICOLI INDUSTRIALI**

ELECTROHYDRAULIC SCISSOR LIFTS FOR HEAVY VEHICLES  
PONTS ELEVATEURS ELECTROHYDRAULIQUES A CISEAUX POUR POIDS LOURDS  
ELEKTROHYDRAULISCHE SCHEREN-HEBEBÜHNE FÜR SCHWERE FAHRZEUGE

Made in Italy 



## PONTI SOLLEVATORI ELETTRIDRAULICI A FORBICE PER VEICOLI INDUSTRIALI

### ELECTROHYDRAULIC SCISSOR LIFTS FOR HEAVY VEHICLES

#### TRACCIATO TECNICO COSTRUTTIVO

- Funzionamento elettroidraulico.
- Realizzazione secondo le vigenti normative.
- Comandi "uomo presente". Tensione ausiliaria 24 V.
- Dispositivo acustico e comando a due mani nell'ultima fase di discesa.
- Valvola di sicurezza contro i sovraccarichi.
- Valvola di sicurezza su ogni cilindro contro la lesione o la rottura dei tubi.
- Controllo con valvola compensata della velocità di discesa.
- **Dispositivo elettronico per il controllo ed il costante mantenimento del parallelismo delle due pedane, indipendentemente dalla distribuzione del carico. Il sistema di parallelismo viene controllato da PLC.**
- Fotocellula di sicurezza per la posizione delle due pedane.
- Dispositivo apposito per il controllo e l'effettuazione dello stazionamento delle due pedane.
- Possibilità di posizionamento della centrale di comando secondo le necessità.
- Olio per circuito idraulico in dotazione.
- Tasselli di ancoraggio al suolo in dotazione.

#### TECHNICAL AND STRUCTURAL LAY-OUT

- Electro-hydraulic operating.
- Built in conformity with the european normative laws in force.
- "Man standing-by" controls. Auxiliary tension 24 V.
- Sound device and two hand control during the last descent phase.
- Safety-valve against overloads.
- Safety-valve on each cylinder against damage or breackage of pipes.
- Check through a valve adjusting the descent speed.
- **Electronic device for the check and constant keeping of the parallelism of the two platforms independently from the load distribution. System of parallelism is checked by PLC.**
- Safety photocell for the position of the two platforms.
- Special device for the check and the execution of the standing of the two platforms.
- Possibility to install the control-box according to the necessities.
- Delivered with oil for the hydraulic circuit.
- Equipped with anchor small blocks.



# PONTS ELEVATEURS ELECTROHYDRAULIQUES A CISEAUX POUR POIDS LOURDS

## ELEKTROHYDRAULISCHE SCHEREN-HE- BEBÜHNE FÜR SCHWERE FAHRZEUGE

### RELEVÉ TECHNIQUE

- Fonctionnement électrohydraulique.
- Réalisation selon les lois en vigueur.
- Commande "homme mort". Tension auxiliaire 24 V.
- Dispositif sonore et commande à deux mains dans la dernière phase de descente.
- Vanne de sécurité anti-surcharges.
- Vanne de sécurité sur chaque cylindre pour éviter l'endommagement ou la rupture des tuyaux.
- Vanne de compensation de la vitesse de descente.
- **Dispositif électronique pour le contrôle et le constant maintien du parallélisme des deux chemins de roulements, indépendamment de la distribution de la charge. Le système de parallélisme est contrôlé par PLC.**
- Capteurs de sécurité pour le positionnement des deux chemins de roulements.
- Dispositif de paramétrage du stationnement des chemins de roulement.
- Possibilité de positionner la centrale de commande selon les besoins.
- Livrés avec l'huile pour le circuit hydraulique.
- Chevilles d'ancrage au sol fournies.

### TECHNISCHE UND KONSTRUKTIVE ANGABEN

- Elektrohydraulischer Betrieb.
- Herstellung unter Berücksichtigung der gültigen Europäischen Normen.
- "Stand-by-Steuerung". Steuerspannung 24 V.
- Akustisches Signal und Zweihand-Steuerung während der letzten Absenkphase.
- Sicherheitsventil als Überlastungsschutz.
- Sicherheitsventil auf jedem Zylinder für die Überwachung der Druckleitungen.
- Sicherheitsventil zur Kontrolle der Absenkgeschwindigkeit.
- **Elektronische Vorrichtung zur Überwachung und ständige Gewährleistung der Fahrschienausrichtung, unabhängig von der Lastenverteilung. Elektronische Gleichlaufüberwachung (PLC).**
- Sicherheitsphotozelle zur Überwachung der Fahrschieneinstellung.
- Vorrichtung zur Überwachung und Sicherung der Fahrschienen in die gewünschte Arbeitsstellung.
- Das Steuerpult kann beliebig aufgestellt werden.
- Wird mit Öl für die hydraulische Schaltung geliefert.
- Ausgestattet mit schmaler Grundplatte.





**9 TON**    **13 TON**    **23 TON**    **33 TON**



ART. 902



**QUADRO ELETTRICO DI COMANDO**  
 Electric control board  
 Cadre électrique de commande  
 Elektrische Steuerschalttafel



**UNITÀ IDRAULICA DI COMANDO**  
 Control hydraulic unit  
 Unité hydraulique de commande  
 Hydraulische Überwachungseinheit



Modello a pavimento  
Floored model  
Modèle au sol  
Überflur-Modell



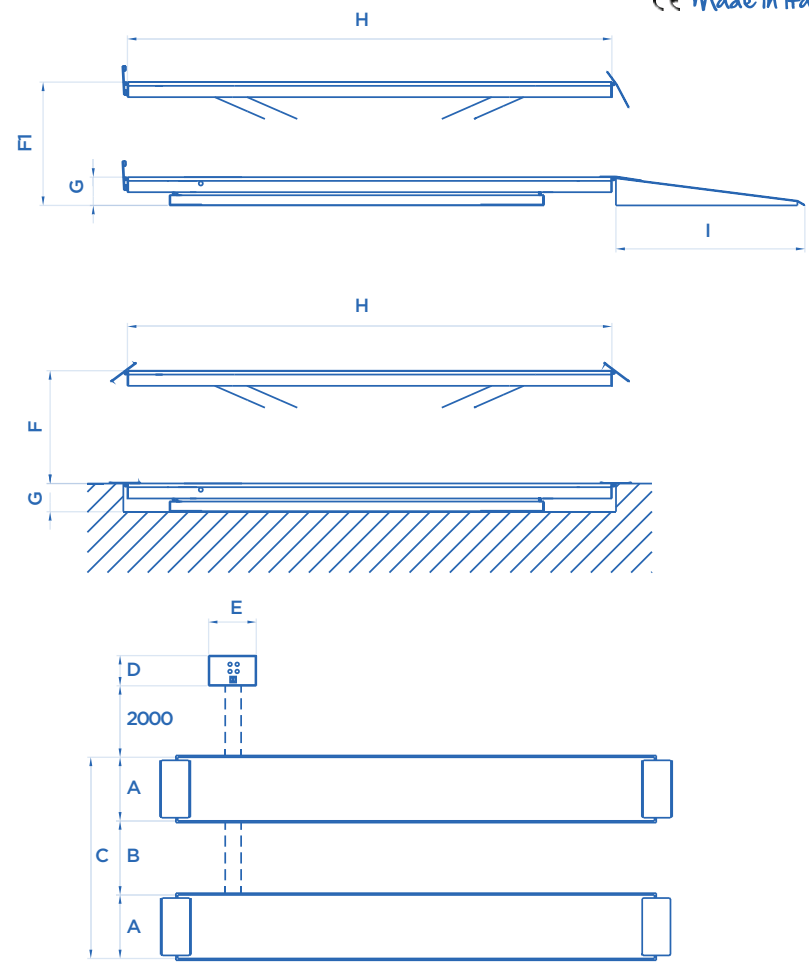







Modello a scomparsa  
Disappearing model  
Modèle encastrable  
Unterflur-Modell



ART. 910/SM

**OPTIONAL** Pag. 122

 Potenza motore • Motor power • Puissance moteur • Motorleistung

ART.			Motore trifase Three-phase motor Moteur triphasé Netzspannung	A 	B 	C 	D 	E 	F 	F1 	G 	H 	I 		
<b>900</b>	9000 Kg	5,5 KW	400V • 50HZ	780	1100	2660	450	600		1900		<b>6000</b>	2700	4850	
<b>910</b>	9000 Kg	5,5 KW		780	1100	2660	450	600	1510				<b>6000</b>		4250
<b>910/SM</b>	9000 Kg	5,5 KW		780	*	*	450	600	1510				<b>4600</b>		4000
<b>901</b>	13000 Kg	7,5 KW		780	1100	2660	450	600		1900			<b>7000</b>	2700	5600
<b>911</b>	13000 Kg	7,5 KW		780	1100	2660	450	600	1510			390	<b>7000</b>		5000
<b>902</b>	23000 Kg	8,8 KW		780	1100	2660	450	600		1900			<b>8000</b>	2700	7950
<b>912</b>	23000 Kg	8,8 KW		780	1100	2660	450	600	1510				<b>8000</b>		7350
<b>903</b>	33000 Kg	15 KW		780	1100	2660	580	800		1900			<b>9000</b>	2700	10600
<b>913</b>	33000 Kg	15 KW		780	1100	2660	580	800	1510				<b>9000</b>		10000

26  
TON

46  
TON

60  
TON



ART. 907

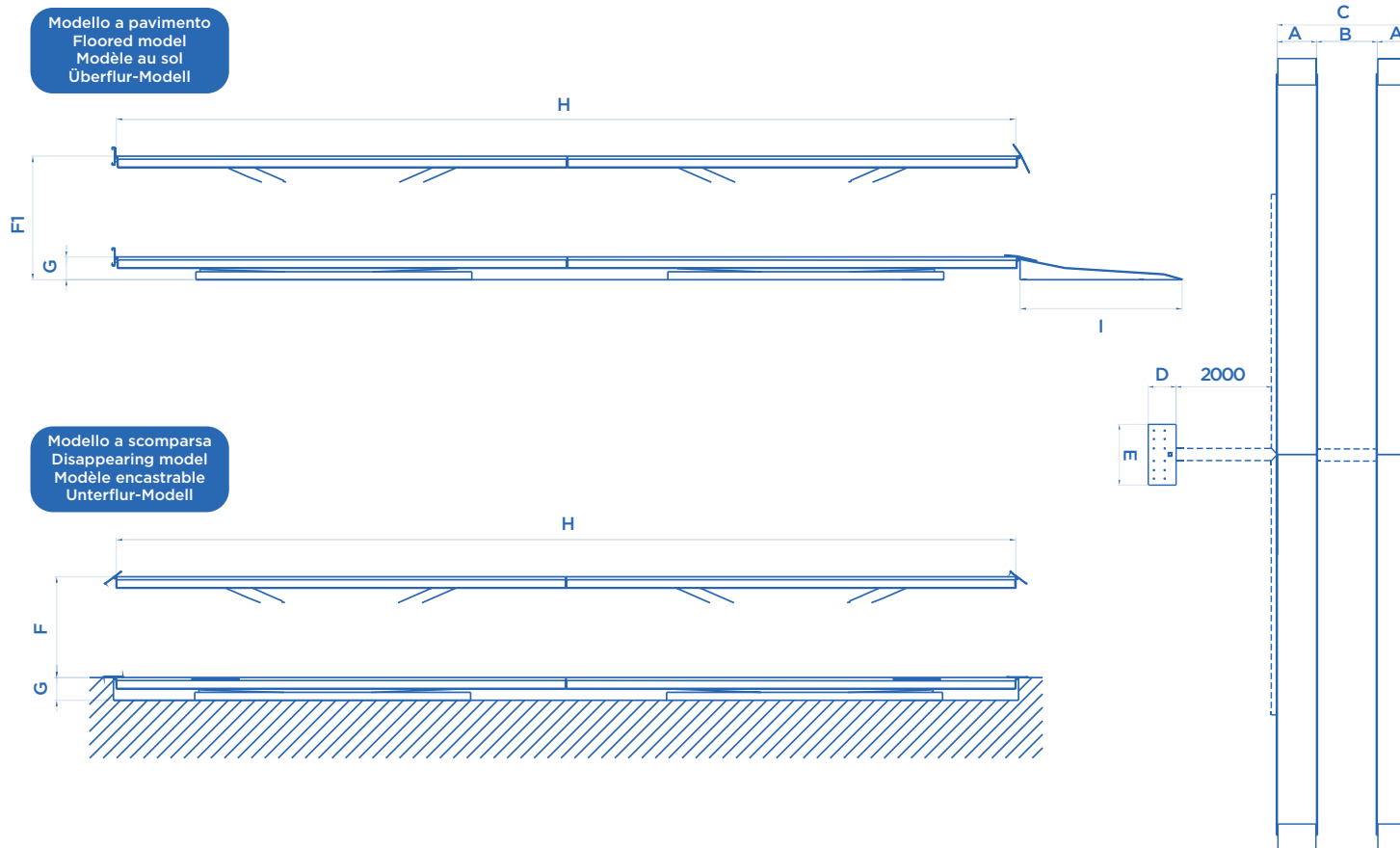

**OPTIONAL** Pag. 122

ART.			Motore trifase Three-phase motor Moteur triphasé Netzspannung	A mm	B mm	C mm	D mm	E mm	F mm	F1 mm	G mm	H mm	I mm	
<b>906</b>	26000 Kg	2x7,5 KW	400V • 50HZ	780	1100	2660	650	1200	1510	1900	390	<b>14000</b>	2700	10600
<b>916</b>	26000 Kg	2x7,5 KW		780	1100	2660	650			<b>14000</b>		10000		
<b>907</b>	46000 Kg	2x8,8 KW		780	1100	2660	650			1900		<b>16000</b>	2700	15300
<b>917</b>	46000 Kg	2x8,8 KW		780	1100	2660	650			1510		<b>16000</b>	14700	
<b>908</b>	60000 Kg	2x15 KW		780	1100	2660	650			1900		<b>16500</b>	2700	20600
<b>918</b>	60000 Kg	2x15 KW		780	1100	2660	650			1510		<b>16500</b>	20000	

 Potenza motore • Motor power • Puissance moteur • Motorleistung





+



## ART. 912+912

Questa soluzione prevede l'installazione fisica di due sollevatori il cui funzionamento, a discrezione dell'operatore, può essere:

**SIMULTANEO:** le quattro pedane dei due ponti si sollevano in modo perfettamente sincronizzato per poter operare su mezzi molto lunghi.

**INDIPENDENTE:** i due sollevatori funzionano in modo indipendente l'uno dall'altro, garantendo la possibilità di operare in contemporanea su due veicoli differenti.

This solution entails the physical installation of two lifts with two different modes of operation, which can be chosen at the operators own discretion:

**SIMULTANEOUS:** all four footboards of both lifts move together in a perfectly synchronous movement, allowing you to operate on long vehicles.

**INDEPENDENT:** both lifts operate independently, allowing you to operate on two different vehicles at the same time.

Cette solution prévoit l'installation physique de deux élévateurs pour deux configurations de travail différentes, au choix de l'opérateur:

**SIMULTANÉE:** les quatre chemins de roulement des deux élévateurs se lèvent de manière parfaitement synchronisée pour pouvoir intervenir sur des véhicules très longs.









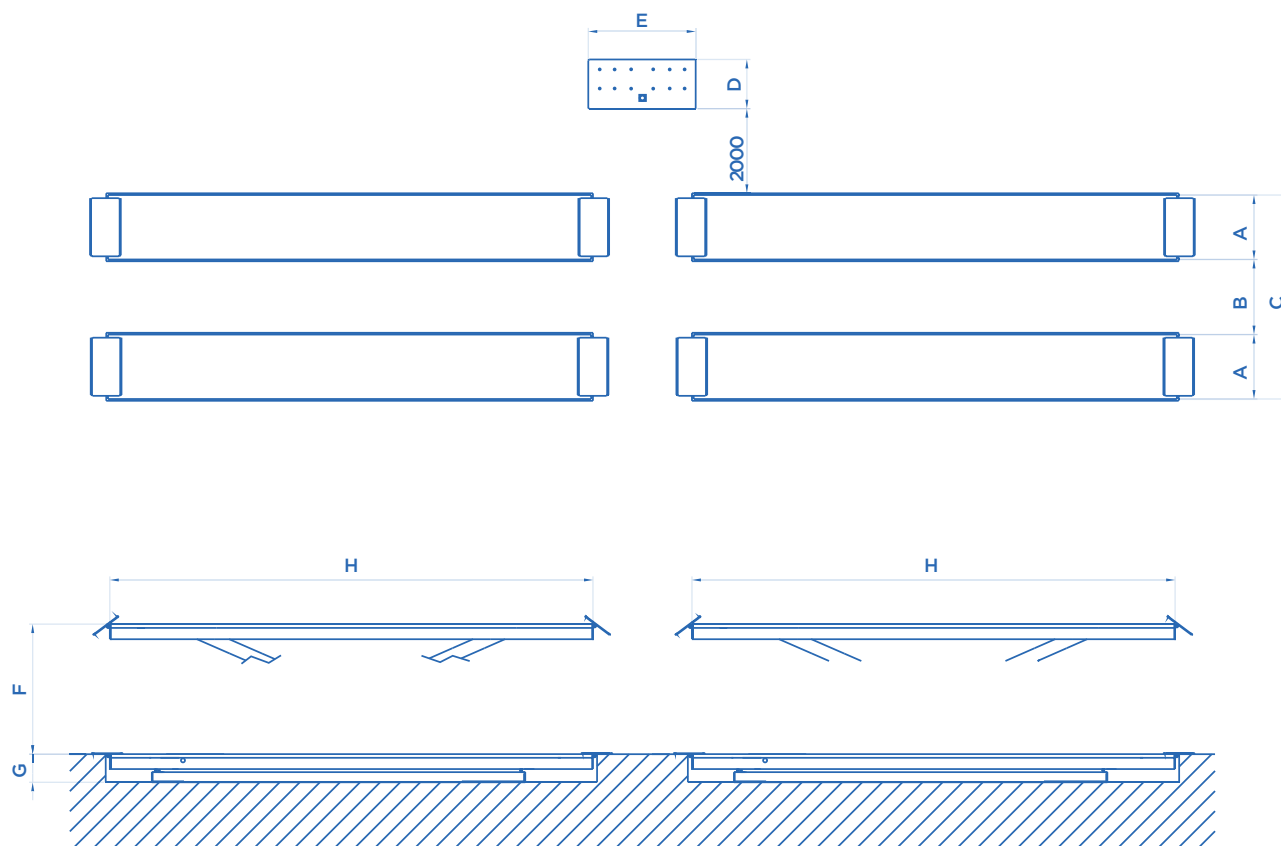

**INDÉPENDANTE:** les deux élévateurs fonctionnent indépendamment l'un de l'autre. Il est possible de travailler sur deux véhicules différents en même temps.

Diese Lösung beinhaltet den physischen Einbau von zwei Hebebühnen, deren Betriebsweise kann nach eigenem Ermessen des Betreibers ausgewählt sein:

**SIMULTAN:** die vier Fahrschienen der zwei Hebebühnen erheben sich vollständig synchronisch, um mit sehr langen Fahrzeugen arbeiten zu können.

**UNABHÄNGIG:** die zwei Hebebühnen funktionieren unabhängig voneinander, um mit zwei verschiedenen Fahrzeugen gleichzeitig arbeiten zu können.



ART.			Motore trifase Three-phase motor Moteur triphasé Netzspannung	A 	B 	C 	D 	E 	F 	G 	H 	
<b>910+910</b>	9000+9000 Kg	2x5,5 KW	400V • 50HZ	780	1100	2660	650	1200	1510	390	<b>6000</b>	8500
<b>911+911</b>	13000+13000 Kg	2x7,5 KW		780	1100	2660	650		1510	390	<b>7000</b>	10000
<b>912+912</b>	23000+23000 Kg	2x8,8 KW		780	1100	2660	650		1510	390	<b>8000</b>	14700
<b>913+913</b>	33000+33000 Kg	2x15 KW		780	1100	2660	650		1510	390	<b>9000</b>	20000

**OPTIONAL** Pag. 122

## ACCESSORI EXTRA DOTAZIONE

EXTRA EQUIPMENT • ACCESSOIRES EN OPTION • EXTRA ZUBEHÖR

**KIT** **X2**

### ART. 920 KIT PER LA SALITA E DISCESA PARTE ANTERIORE

Up and down kit - front side  
Kit pour la montée et descente partie antérieure  
2 Überfahrtschienen (vorn)

L = 2.700 mm.



### IMPIANTO DI ILLUMINAZIONE A LED

Led lighting system  
Kit d'éclairage led  
LED Beleuchtungsanlage



**ART. 923** ✓ H = 4600 • 6000 mm  
**ART. 923/A** ✓ H = 7000 • 8000 • 9000 mm



### ART. 926 INCAVO PREDISPOSTO SULLE PEDANE PER L'ALLOGGIAMENTO DEL PROVA GIOCHI IDRAULICO

Cavity on the footboards for housing of play-testing device  
Cavité prédisposée sur les chemins de roulement pour l'encastrement des plaques à jeux  
Aussparungen im vorderen Teil der Fahrschienen, um eine Gelenkspiel-Testvorrichtung aufzunehmen



### PROLUNGHE DI COLLEGAMENTO TRA IL SOLLEVATORE E LA CENTRALINA DI COMANDO (1 m)

Connection extensions between the hoist and the control box  
Rallonges de jonction entre l'élevateur et le pupitre de commande  
Verlängerungsschläuche (zwischen Hebebühne und Steuerpult)



**ART. 922** ✓ ART. 900 • 901 • 902 • 910 • 911 • 912  
**ART. 922/A** ✓ ART. 903 • 913  
**ART. 922/B** ✓ ART. 906 • 916  
**ART. 922/C** ✓ ART. 907 • 917  
**ART. 922/D** ✓ ART. 908 • 918

### TELAI PER INCASSO

Embedding frames  
Caissons pour modèles encastrables  
Metallrahmen für Grube



**ART. 921** ✓ ART. 910 • 910/SM • 911 • 912  
**ART. 921/A** ✓ ART. 913  
**ART. 921/B** ✓ ART. 916 • 917  
**ART. 921/C** ✓ ART. 918

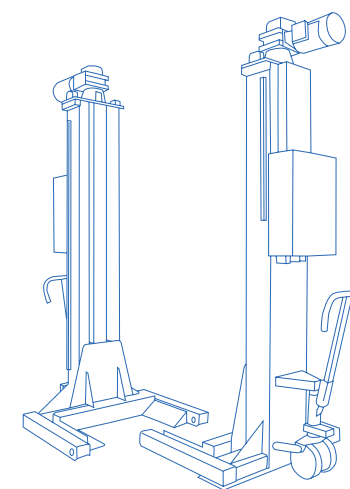

## **SOLLEVATORI A COLONNE MOBILI**

MOBILE COLUMN LIFTS  
ELEVATEURS A COLONNES MOBILES  
FAHRBARER LKW-RADGREIFER

Made in Italy 



SERIE 952 • 953

3000  
4000 **KG**



ART. 952

**OPTIONAL** Pag. 130



ART. 953



## TRACCIATO TECNICO COSTRUTTIVO

- Sollevamento a mezzo di viti trapezoidali rullate, in acciaio ad alta resistenza, a passo fine per rendere autofrenanti i carrelli.
- 4 rulli di scorrimento per ogni singolo carrello abbinati a 4 pattini garantiscono una perfetta aderenza e scorrevolezza.
- Dispositivo meccanico di blocco del movimento in caso di eccessiva usura della chiocciola portante.
- Motore elettrico sovradimensionato dotato di protezione termica.
- Il dispositivo di funzionamento è composto da microprocessore (PLC) per il controllo del sincronismo e il riallineamento automatico e la gestione delle modalità di funzionamento.
- **Pulsante di emergenza con autoritenuta su tutte le colonne.**
- Struttura completamente premontata.
- Pompetta di ingrassaggio in dotazione.

## TECHNICAL AND STRUCTURAL LAY-OUT

- Trapezoidal lifting screws made of highly resistant rolled steel, short pitch designed for self-braking carriages.
- 4 sliding rollers per carriage plus 4 sliding shoes guarantee a perfect adhesion and flowability.
- Mechanical stop device when the load bearing nut gets excessively worn.
- Oversized motor with thermal protection.
- Operating device composed by a microchip (PLC) for the regulation of synchronism and the automatic re-alignment as well as working modalities management.
- **Latching emergency switch on every column.**
- Supplied with greaser.

## RELEVÉ TECHNIQUE

- Levage par vis trapézoïdales comprimées, en acier haute résistance. Pas de vis fin pour des chariots auto-freinant.
- Le chariot court sur 4 galets et 4 patins réglables pour une adhésion et une mobilité parfaites.
- Dispositif mécanique de blocage en cas d'usure excessive de l'écrou porteur.
- Moteur électrique surdimensionné avec protection thermique.
- Synchronisation, réalignement automatique et gestion des modalités de fonctionnement par automate (API).
- **Bouton d'urgence à accrochage.**
- Structure entièrement assemblée en usine.
- Poire de graissage fournie.

## TECHNISCHE UND KONSTRUKTIVE ANGABEN

- Hub mit abrollende Trapez- und Feingewinde Spindeln aus hochfestem Stahl, um die Abbremsung der Hubschlitten zu erreichen.
- 4 Rollen mit 4 Gleitlagern für jeden einzelnen Hubschlitten, um eine perfekte Haftfähigkeit und bestes Gleitvermögen zu sichern.
- Mechanische Sperrvorrichtung der Bewegung im Fall eines exzessives Tragmutterverschleiß.
- Überdimensionierter Elektromotor mit thermischem Schutz.
- Betriebsvorrichtung bestehend aus einem Mikroprozessor (PLC), der sowohl für den Gleichlauf als auch für die automatische Wiederausrichtung der Fahrschienen verantwortlich ist, ebenfalls auch für den Arbeitsverlauf.
- **Notausschalter mit Selbstrückhaltung.**
- Ausgestattet mit Fettschmierungspumpe.

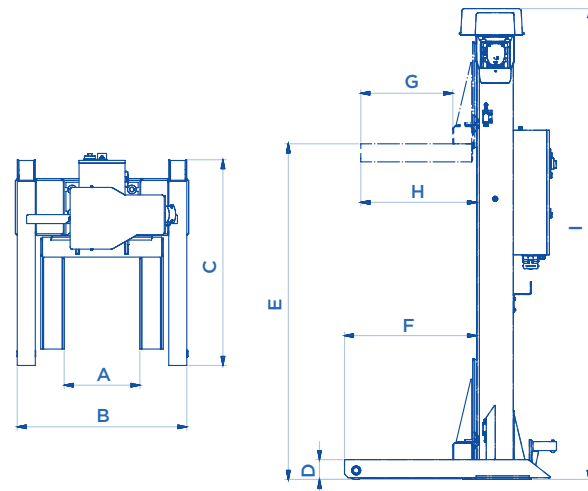

## CONFIGURAZIONI • CONFIGURATIONS • CONFIGURATIONS • EINSATZMÖGLICHKEITEN

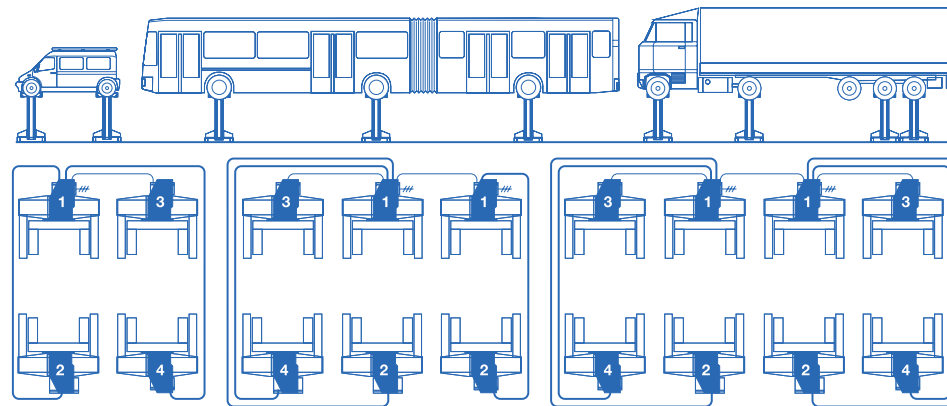

ART. 952 • 953

ART. 953/A

ART. 953/B

ART.			Motore trifase Three-phase motor Moteur triphasé Netzspannung	A mm	B mm	C mm	D mm	E mm	F mm	G mm	H mm	I mm	MAX	MIN	KG
952	3000 Kg	2,6 KW	400V • 50HZ	420	940	1140	110	1860	730	510	640	2620	800	550	420
953	4000 Kg	2,6 KW		580	1100	1050	110	1860	645	400	530	2620	1200	900	450

**SERIE 959 • 963**

**6500  
8500 KG**



**ART. 959**

**OPTIONAL** Pag. 130

## TRACCIATO TECNICO COSTRUTTIVO

- Colonne realizzate con struttura in acciaio saldato, con carrello di sollevamento a scorrimento interno, dotato di quattro ruote di grosso diametro che garantiscono una perfetta aderenza e scorrevolezza e consentono di ridurre al minimo gli interventi di manutenzione.
- Chiocchie di sicurezza e portanti in bronzo.
- Lubrificazione della vite motrice assicurata da un sistema montato direttamente sulla chiocciola portante.
- Martinetto di sollevamento per lo spostamento della colonna dotato di valvola limitatrice di portata e timone di manovra manuale con ruote rivestite in poliuretano e dotate di cuscinetti a sfera.
- Il dispositivo di funzionamento è composto da microprocessore (PLC) per il controllo del sincronismo e il riallineamento automatico e la gestione delle modalità di funzionamento.
- **Comandi con pulsantiera mobile da collegare alla colonna dalla quale si desidera azionare il sollevatore.**
- Pulsante di emergenza sul quadro elettrico di ogni singola colonna.

## TECHNICAL AND STRUCTURAL LAY-OUT

- Columns made of welded steel structure, internal sliding lifting trolley equipped with 4 wheels of big diameter which assure a perfect adhesion and smoothness and reduce to the minimum the maintenance operations.
- Bronze load bearing and safety screws.
- Lubrication of the screws assured by a device mounted directly on the bearing nut.
- Lifting jack to move the column, equipped with a capacity modulating valve and a hand move rudder with wheels lined in polyurethane and equipped with ball bearings
- Operating device composed by a microprocessor (PLC) for the regulation of the synchronism, the automatic re-alignment and also for the working ways running.
- **Controls with a mobile push-button board to be connected to the column from which you want the lift starts working.**
- Emergency button on the switchboard of each single column.

## RELEVÉ TECHNIQUE

- Structure de la colonne en acier soudé, avec chariot de levage à coulissement interne et 4 roues d'un diamètre assez important pour permettre une adhérence et un coulissement parfaits afin de réduire au minimum les interventions pour entretien.
- Ecrous porteurs et de sécurité en bronze.
- Lubrification de la vis assurée par un système monté directement sur l'écrou porteur.
- Vérin de levage pour le déplacement de la colonne, équipé de vanne limitatrice de la portée et de timon de manoeuvre manuel avec roues revêtues en vulkollan équipées de roulements à billes.
- Le dispositif de fonctionnement se compose d'un microprocesseur (PLC) qui assure la synchronisation et le réaligement automatique ainsi que les différents modes de fonctionnement.
- **Commande filaire mobile, à brancher sur la colonne de votre choix pour l'actionnement de l'élévateur.**
- Bouton de sécurité sur chaque boîtier électrique.

## TECHNISCHE UND KONSTRUKTIVE ANGABEN

- Die Radgreifer sind aus geschweißtem Stahl hergestellt, mit einem innenseitigen Führungswagen für die Hebung, der mit 4 Rädern von großem Durchmesser ausgestattet ist. Diese Räder sichern eine perfekte Haftung und Lauf und weisen einen geringen Wartungseinsatz auf.
- Sicherheits- und Trag- Muttern aus Bronze.
- Selbstschmierung der Antriebsspinde durch eine auf der Tragmutter montierte Schmiervorrichtung.
- Hubwagen für die Verschiebung des Radgreifer in die gewünschte Position, ausgestattet mit einem Überlastungsventil, mit handbeweglichen Deichsel und kugelgelagerten Polyurethanräder.
- Überwachungsvorrichtung bestehend aus einem im Schaltkasten installierten Haupt-Mikroprozessor (PLC), der sowohl die Überwachung des Gleichlaufs als auch die sich anschließende Wiederausrichtung der gesamten Radgreifer-Hebeanlage regelt.
- **Bedienung mittels einem mit der Vorab ausgewählten Säule verbundenen Fernbedienung.**
- Jeder Säule wird mit einem Notausschalter an dem Schaltkasten geliefert.

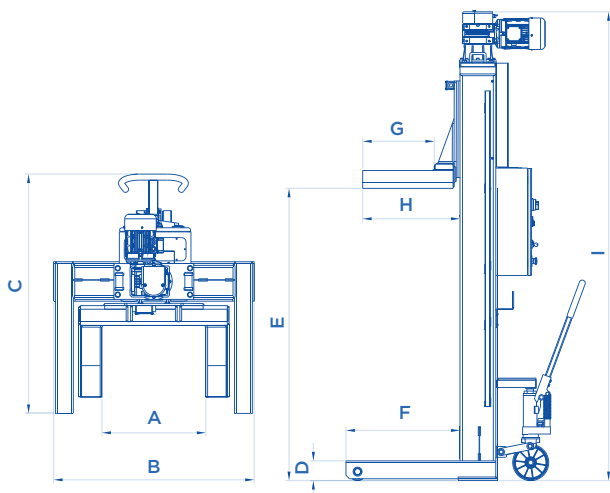

## CONFIGURAZIONI • CONFIGURATIONS • CONFIGURATIONS • EINSATZMÖGLICHKEITEN

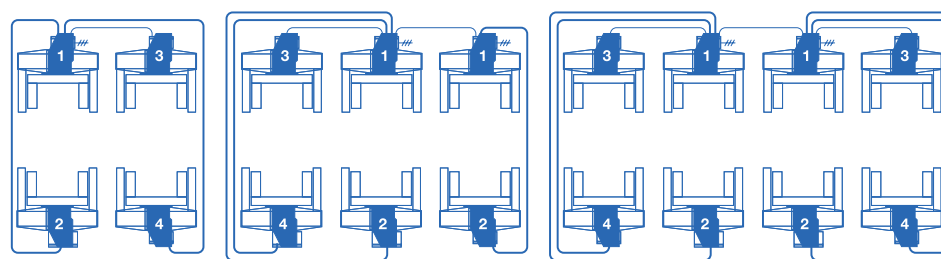
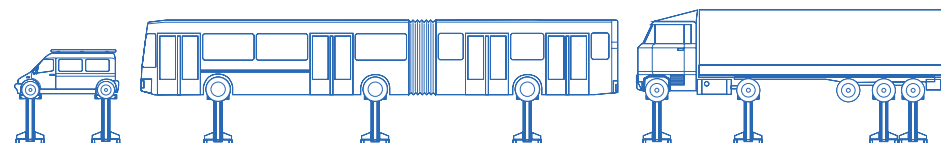

ART. 959 • 963

ART. 959/A • 963/A

ART. 959/B • 963/B

ART.			Motore trifase Three-phase motor Moteur triphasé Netzspannung	A mm	B mm	C mm	D mm	E mm	F mm	G mm	H mm	I mm	Ø MAX	Ø MIN	KG
959	6500 Kg	2,6 KW	400V • 50HZ	580	1100	1370	110	1770	635	400	550	2760	1200	900	475
963	8500 Kg	2,6 KW		580	1100	1370	120	1770	635	400	550	2760	1200	900	540





SERIE 995 • 995W

ELETTROIDRAULICI  
ELECTROHYDRAULIC  
ELECTROHYDRAULIQUES  
ELEKTROHYDRAULISCH

WIRELESS  
SERIE 995W



ART. 995W

OPTIONAL Pag. 130



SERIE 995W



SERIE 995W



SERIE 995W



SERIE 995W

## TRACCIATO TECNICO COSTRUTTIVO

- Sollevamento a mezzo di pistoni idraulici equipaggiati con valvola di sicurezza inserita direttamente nei cilindri contro la rottura accidentale dei tubi di alimentazione.
- Sistema elettroidraulico di controllo che garantisce l'allineamento e il sincronismo dei carrelli indipendentemente dalla ripartizione del carico.
- Velocità di discesa controllata con compensazione idraulica.
- Appoggi meccanici di sicurezza ad inserimento automatico.
- Modalità di discesa lenta per consentire un corretto e preciso posizionamento del veicolo su appositi sostegni o colonnette.
- **Ampio display touchscreen sulla colonna master per selezionare la modalità di funzionamento, visualizzare le altezze delle colonne, impostare la corsa desiderata, visualizzare messaggi, avvisi funzionali e situazioni di allarme** (serie 995W).
- Colonne dotate di due batterie ad alta capacità che garantiscono una grande autonomia, ricaricabili utilizzando una comune presa da 220 V (serie 995W).
- Il sollevatore è dotato di un sistema di comunicazione che utilizza dispositivi Wireless LAN, realizzati e certificati per operare in ambito industriale, in ambienti particolarmente critici. Questo assicura elevati standard di sicurezza, immunità ai disturbi e affidabilità (serie 995W).

## TECHNICAL AND STRUCTURAL LAY-OUT

- Lifting by hydraulic pistons equipped with safety valve, which is placed directly inside the cylinders for the accidental breaking of the feeding pipes.
- Electrohydraulic control system which assures the alignment and the synchronism of the trolleys whatever the distribution of the weight is.
- Control of the descent speed by hydraulic compensation.
- Safety mechanical supports at automatic insertion.
- Descent slow way to allow a correct and precise positioning of the vehicle on the proper supports or stands.
- **Large touchscreen display on the master column to select the functioning way, to visualize the height of the columns, to settle the desired stroke, to visualize messages, functional advices and alarm situations** (serie 995W).
- Columns equipped with two high capacity batteries which assure a great autonomy; they are rechargeable by using a standard plug of 220 V (serie 995W).
- The lift is equipped with a communication system which uses Wireless LAN devices, realized and certified to operate in industrial field, in particularly critical environment. This assures high safety standards, immunity to troubles and reliability (serie 995W).

## RELEVÉ TECHNIQUE

- Levage par vérins hydrauliques à soupape de sécurité embarquée contre toute rupture accidentelle des tuyaux d'alimentation.
- Le système de contrôle électro-hydraulique assure la synchronisation des chariots indépendamment de la répartition de charge.
- Vitesse de descente contrôlée par compensation hydraulique.
- Appuis mécaniques de sécurité à insertion automatique.
- Modalité de descente lente pour une grande précision de positionnement du véhicule sur chandeliers ou chevalets.
- **Ecran à commande tactile de grande dimension sur la colonne primaire. Permet la sélection de la modalité de fonctionnement, la visualisation de la hauteur des colonnes et le paramétrage de la course désirée, ainsi que la visualisation d'alertes fonctionnelles et situations d'urgence** (série 995W).
- Colonnes dotées de deux batteries haute fidélité capable d'assurer une grande autonomie. Rechargeables sur simple prise de courant 220 V (série 995W).
- L'élévateur fonctionne sur un système de communication utilisant la technologie Wireless LAN, projetée et certifiée pour fonctionner en environnement industriel, même critique d'un point de vue sécurité. Ceci vous garantit un haut niveau de sécurité, une grande fiabilité et une imperméabilité aux interférences (série 995W).

## TECHNISCHE UND KONSTRUKTIVE ANGABEN

- Hub durch hydraulische Zylinder, ausgestattet mit Sicherheitsventilen, welche direkt im inneren des Zylinders platziert sind, um das unbeabsichtigte Brechen der Zufuhrleitung zu verhindern.
- Elektrohydraulisches Kontrollsystem, welches den Gleichlauf und das Ausrichten gewährleistet.
- Hydraulische Absenkgeschwindigkeitskontrolle.
- Automatische mechanische Sicherheitsvorkehrungen.
- Langsame Senkbewegung möglich, um das Fahrzeug korrekt und genau auf Stützen oder Böcke zu fahren.
- **Großes "touchscreen" auf der Hauptsäule, um den gewählten Vorgang einzugeben, die Säulenhöhe zu sehen, den Hub zu bestimmen, Abstände, Höhen usw. zu kontrollieren. Funktionsempfehlungen erhalten und für Not-Situationen** (Serie 995W).
- Die Bühne, in der drahtlosen Version, ist ausgestattet mit einem Kommunikationssystem, welches Wireless LAN Elemente benutzt, gebaut und geprüft für arbeiten in industriellen Bereichen und in besonders kritischer Umgebung. Dieses gewährleistet hohe Sicherheits-Standards, Immunität für Störungen und Verlässlichkeit (Serie 995W).

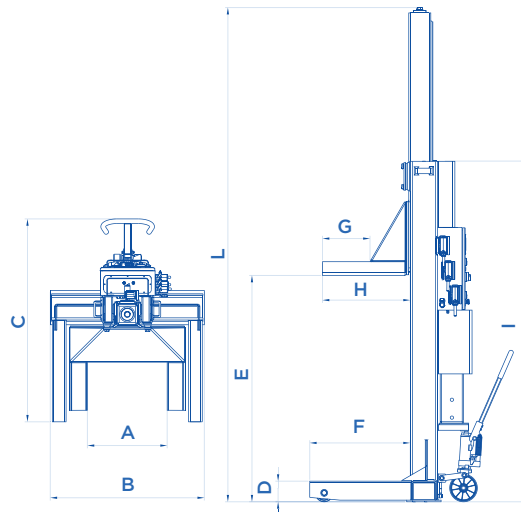

## CONFIGURAZIONI • CONFIGURATIONS • CONFIGURATIONS • EINSATZMÖGLICHKEITEN

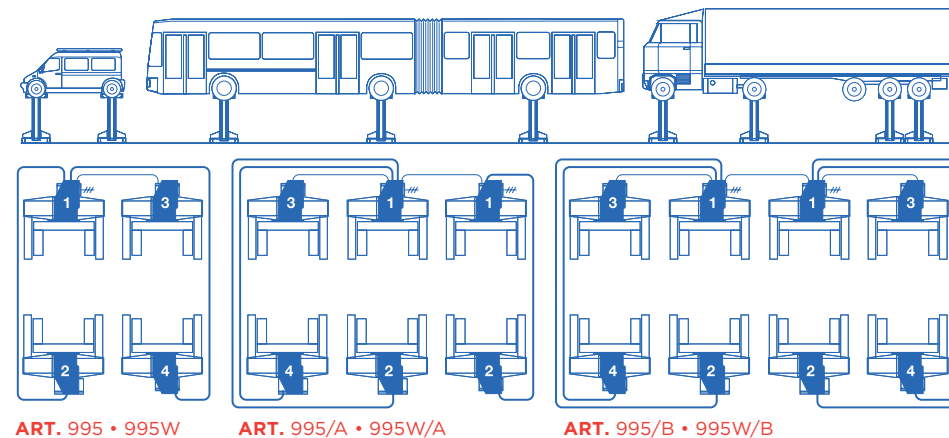

ART.			Motore trifase Three-phase motor Moteur triphasé Netzspannung	Alimentazione caricabatteria Battery charger power Alimentation du chargeur de batterie Ladegerätversorgung	A mm	B mm	C mm	D mm	E mm	F mm	G mm	H mm	I mm	L mm	Ø MAX	Ø MIN	KG
995	8500 Kg	2 KW	400V • 50HZ		580	1100	1325	120	1770	715	350	638	2612	3855	1200	900	640
995W	8500 Kg	3 KW (24Vdc)		220V • 50HZ	580	1100	1325	120	1770	715	350	638	2612	3855	1200	900	720

## ACCESSORI EXTRA DOTAZIONE

EXTRA EQUIPMENT • ACCESSOIRES EN OPTION • EXTRA ZUBEHÖR

### ADATTATORI PER RUOTE DI DIAMETRO INFERIORE A 900 mm

Adapters for wheels having diameter less than 900 mm  
Adaptateurs pour roues d'un diamètre inférieur à 900 mm  
Adapter für räder mit durchmesser unter 900 mm

**ART. 983** → Ø 700 • 500 mm

**ART. 983/A** → Ø 800 • 700 mm

**ART. 983/B** → Ø 900 • 800 mm



7500 Kg

### CARRELLO DOTATO DI FORCHE REGOLABILI

Trolley with adjustable forks  
Chariot avec fourches réglables  
Wagen mit verstellbaren Radgabeln

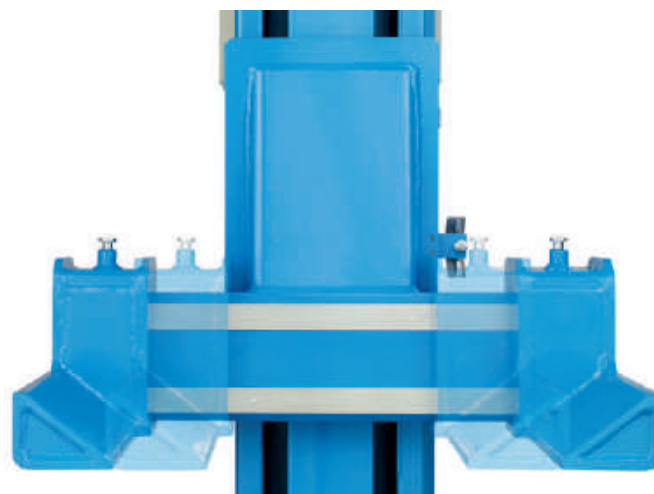
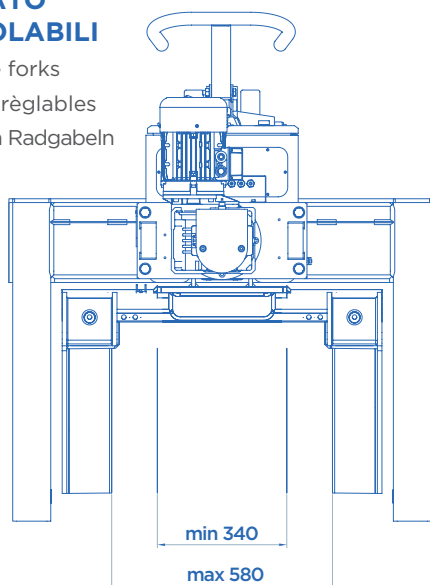

**ART. 983/FM** → Ø 1200 • 500 mm

✓ SERIE 953 • 959 • 963 • 995 • 995W

### KIT PER UTILIZZO ALL'ESTERNO

Extra charge for outdoor use  
Supplément pour installation en extérieur  
Mehrpreis für den äußeren Gebrauch



**ART. 984** ✓ SERIE 959 • 963



## ACCESSORI EXTRA DOTAZIONE

EXTRA EQUIPMENT • ACCESSOIRES EN OPTION • EXTRA ZUBEHÖR

### ART. 985 TRAVERSA LIBERA RUOTE

Free-wheel jacking beam  
Dégage roues  
Achsfreiheber für radfreiheit



20000 Kg

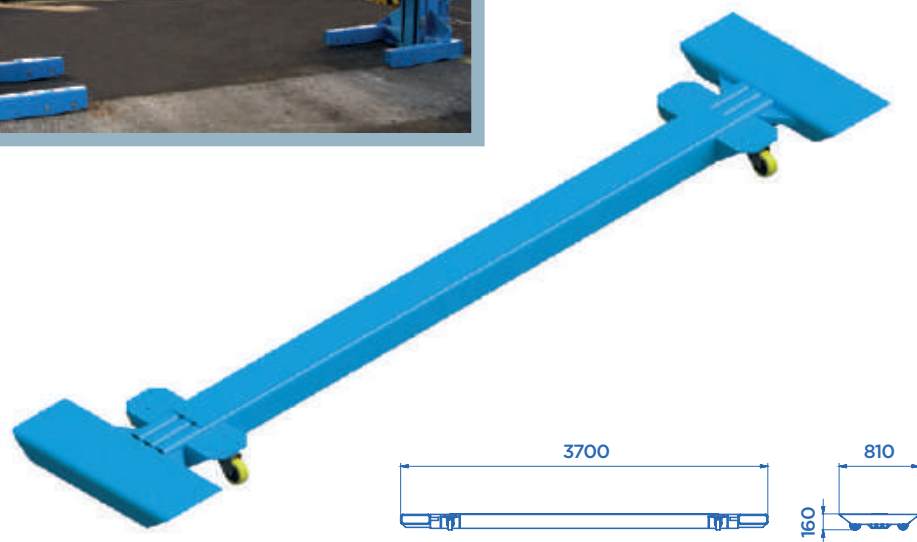

### ART. 985/A TRAVERSA DI SOLLEVAMENTO PER SEMIRIMORCHIO

Jacking beam for semi-trailer  
Traverse de levage pour semi-remorque  
Achsfreiheber für sattelaufleger



7500 Kg

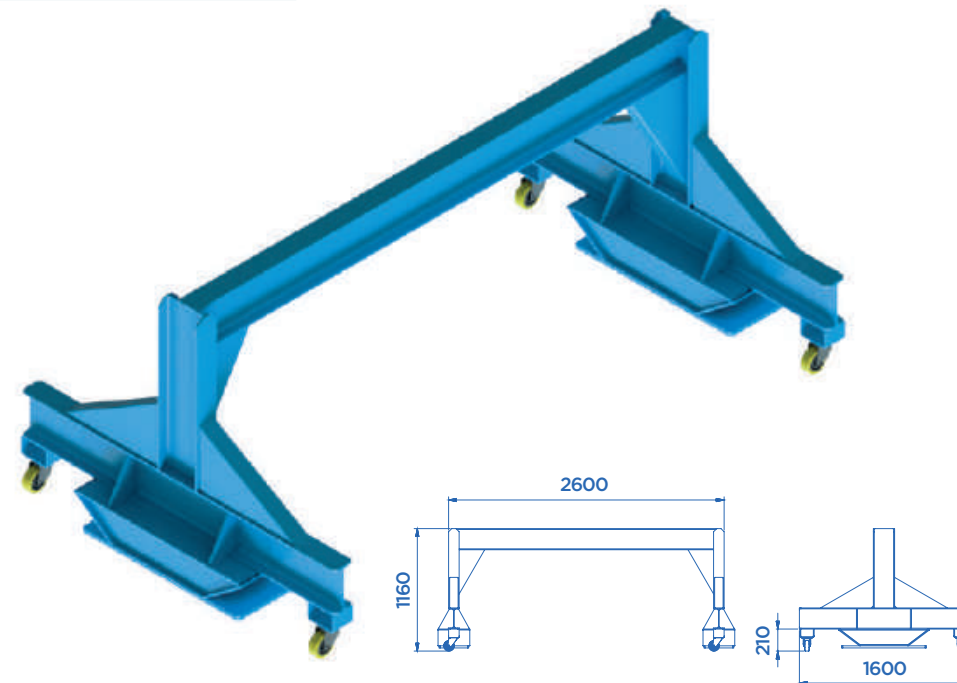

ART. 985 • 985/A ✓ SERIE 959 • 963 • 995 • 995W

## ACCESSORI EXTRA DOTAZIONE

EXTRA EQUIPMENT • ACCESSOIRES EN OPTION • EXTRA ZUBEHÖR

### ART. 982 • 982/B

#### COLONNETTA DI SUPPORTO DOTATA DI RUOTE FISSE PER UNA FACILE MOVIMENTAZIONE

Supporting stand equipped with fixed wheels for an easy movement  
 Chandelle de support équipée de roues fixes pour un déplacement facile  
 Fahrbarer Unterstellbock

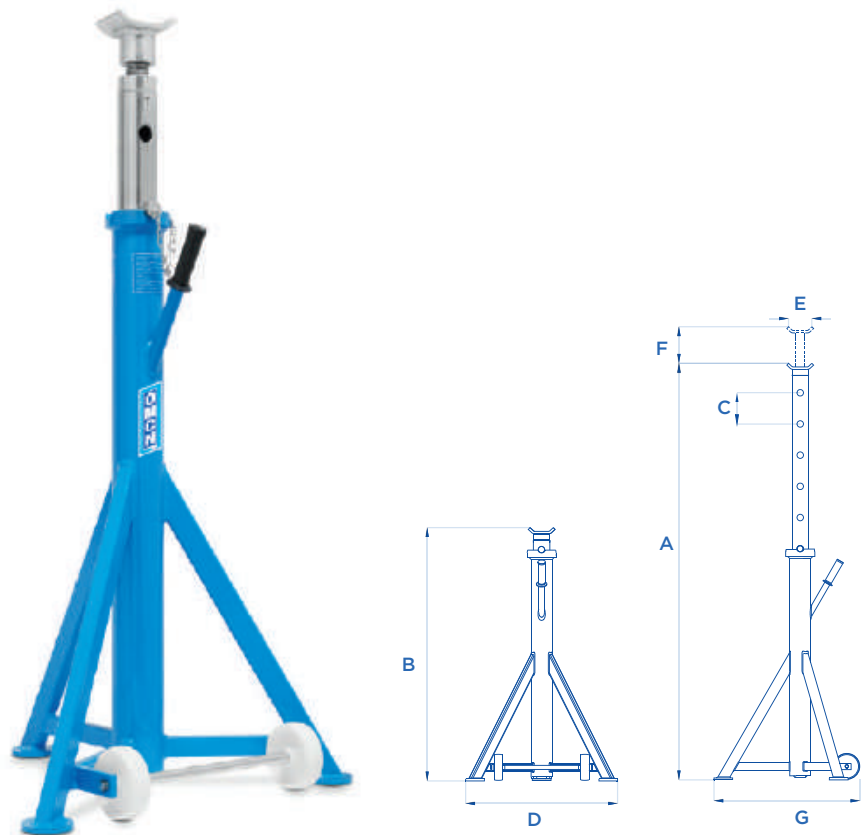



ART.		A mm	B mm	C mm	D mm	E mm	F mm	G mm
<b>982</b>	10000 Kg	2050	1300	150	730	130	70	700
<b>982/B</b>	7200 Kg	2050	1300	150	715	130		700

### ART. 982/A

#### COLONNETTA DI SUPPORTO DOTATA DI RUOTE RIENTRANTI CON L'ALLOGGIAMENTO DEL CARICO

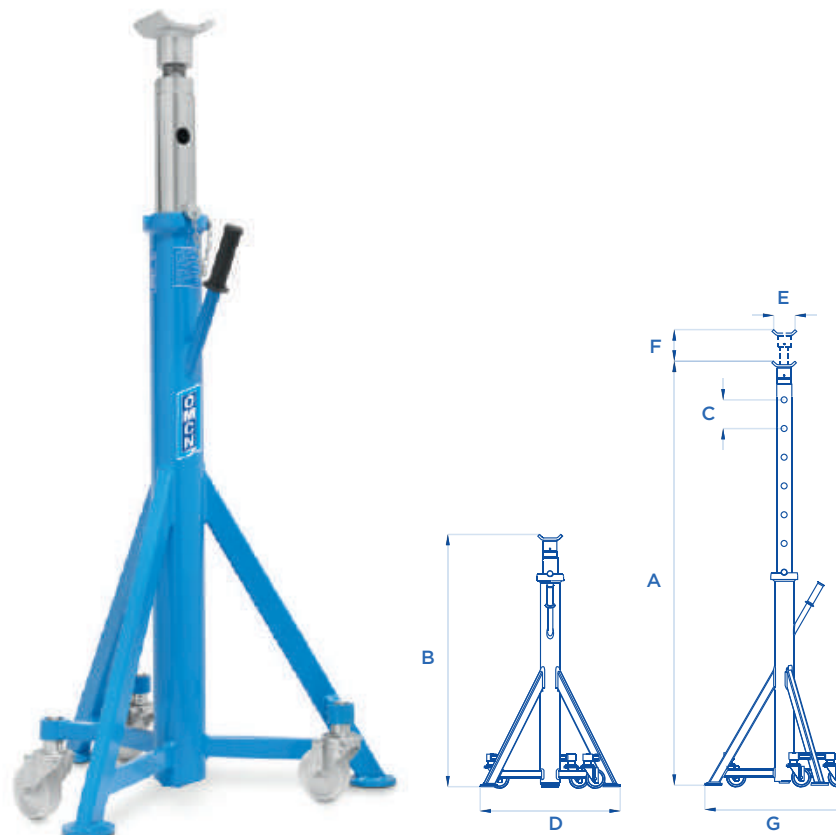
Supporting stand equipped with re-entering wheels for the housing of the loading  
 Chandelle de support équipée de roues rétractables avec logement de la charge  
 Fahrbarer Unterstellbock mit einfedernden Rädern.



ART.		A mm	B mm	C mm	D mm	E mm	F mm	G mm
<b>982/A</b>	10000 Kg	2050	1300	150	730	130	70	660

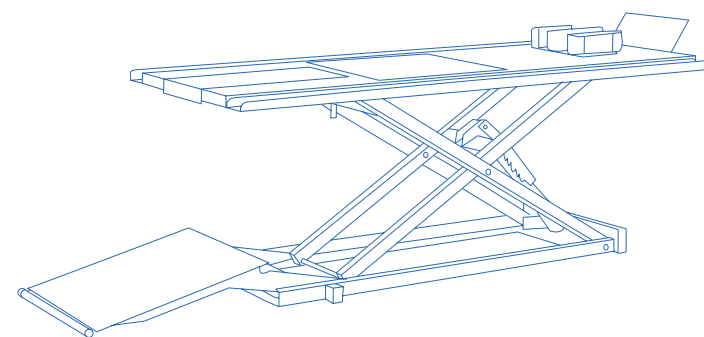

## **SOLLEVATORI PER MOTO**

MOTOR-BIKE LIFTS  
ELEVATEURS POUR MOTOS  
MOTORRAD-HEBEBÜHNEN

Made in Italy 



# SOLLEVATORI PER MOTO

## MOTOR-BIKE LIFTS

## ELEVATEURS POUR MOTOS

## MOTORRAD-HEBEBÜHNEN



### TRACCIATO TECNICO COSTRUTTIVO

- Ferma ruota anteriore a sbalzo per agevolare il posizionamento della moto.
- Morsa manuale in versione ribassata di serie su tutti i modelli.
- Sistema di scorrimento su rulli pieni.
- **Scivolo retrattile per ridurre l'ingombro a terra quando il banco è sollevato.**
- Perni completi di ingrassatori.
- Finestra posteriore estraibile per facilitare l'estrazione della ruota.
- Protezione centrale antiscivolo in alluminio.
- Vaschette porta oggetti di serie (196/P - 196/PI - 196/PL).
- Dotati di cremagliera meccanica dentata di sicurezza.

### RELEVÉ TECHNIQUE

- La butée avant facilite le positionnement de la moto même munie d'un chevalet central.
- Etau manuel extra-plate de série sur tous les modèles.
- Roulement sur galet pleins et non sur patins.
- **Rampe d'accès rétractable: zéro encombrement au sol quand le pont est soulevé.**
- Axes avec graisseurs de série sur tous les modèles.
- Ouverture arrière extractible.
- Plaque de protection centrale en aluminium pour la stabilité des chevalets.
- Bacs zinc de série (196/P - 196/PI - 196/PL).
- Etrier mécanique de sécurité.

### TECHNICAL AND STRUCTURAL LAY-OUT

- Front stop to make it easier to place the motorbike even those with central stand.
- Low profile vice provided with all models.
- Move on full rolls, not sliding blocks.
- **Retractable ramp takes little space on the floor when the lift is up.**
- Pins with greaser embedded on every model.
- Rear opening to facilitate dismounting of the wheel.
- Aluminium protection plate in the middle of the platform to prevent stands from slipping.
- Equipped with galvanized trays (196/P - 196/PI - 196/PL).
- Mechanical safety device.

### TECHNISCHE UND KONSTRUKTIVE ANGABEN

- Verstellvorrichtung für das Vorderrad, um die Positionierung des Motorrads auf ihrem mittleren Kippständer zu erleichtern.
- Manuell ausgeführte versenkbare Klemme, die serienmäßig eingebaut ist.
- Gleitsystem bestehend auf Laufrollen und nicht auf Gleitschuhe.
- **Komplett einziehbaren Rutsche um den Platz, wenn die Werkbank aufgehoben ist, zu sparen.**
- Aufnahmebolzen mit Schmierpressen, die auf jeden, Artikel dieser Weise serienmäßig eingebaut sind.
- Hinter- herausnehmbar Eröffnung.
- Aluminium- rutschfest zentral gelegener Schutz, um die Kippständer abstellen zu lassen.
- Serienmäßige verzinkte Konsole (196/P - 196/PI - 196/PL).
- Mechanische Sicherheitsraststange.

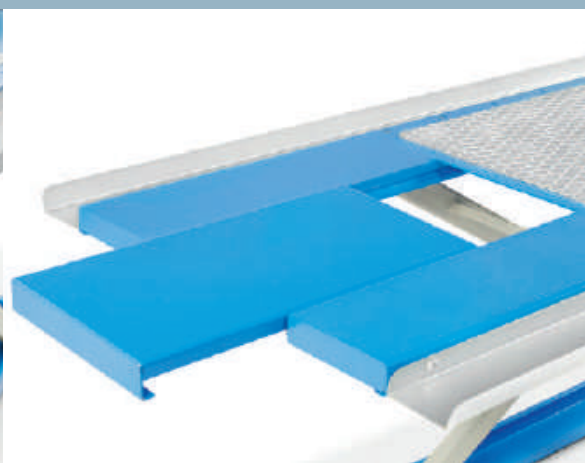



### ART. 196/P CON POMPA IDRAULICA

with hydraulic pump  
avec pompe hydraulique  
mit Hydraulikpumpe

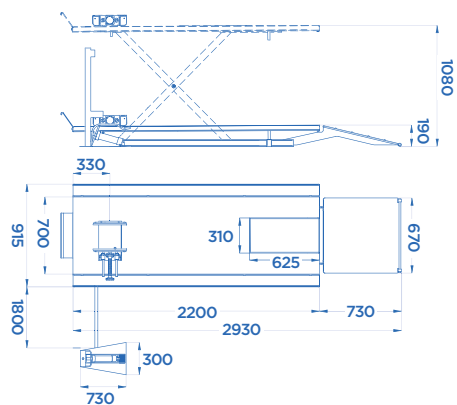

### ART. 196/PL • 196/PL-SP CON POMPA ELETTROIDRAULICA

with electrohydraulic pump  
avec pompe électrohydraulique  
mit elektrohydraulischer Pumpe

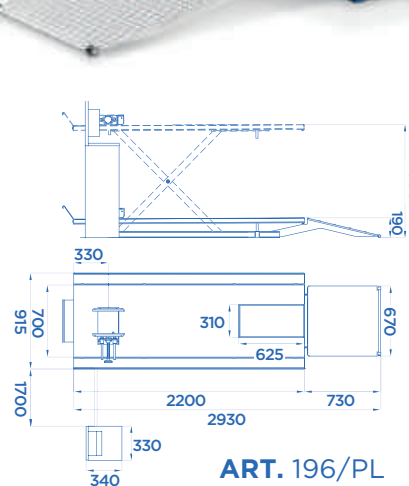

ART. 196/PL

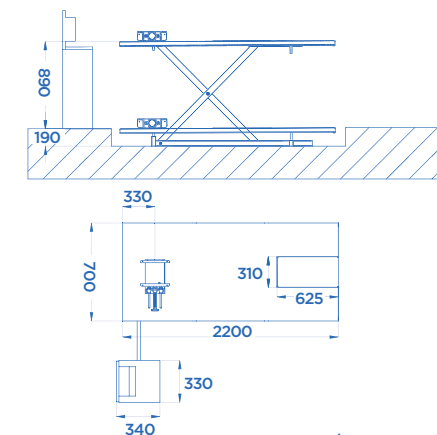



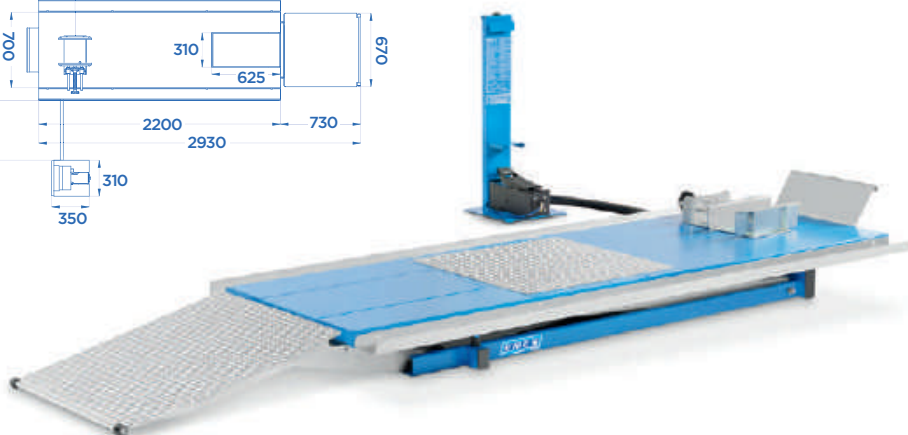
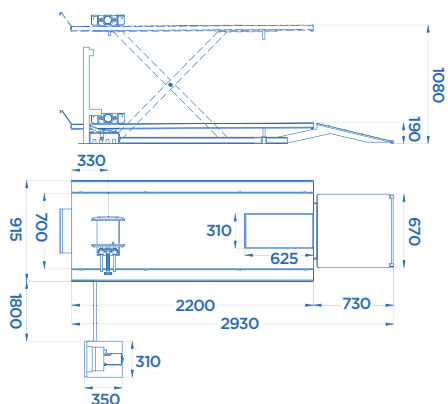

ART. 196/PL-SP

### ART. 196/PI CON POMPA IDROPNEUMATICA

with hydropneumatic pump  
avec pompe hydropneumatique  
mit Hydropneumatikpumpe



**OPTIONAL** Pag. 143

ART.				Motore trifase Three-phase motor Moteur triphasé Netzspannung	
196/P	500 Kg	6 bar			210
196/PI	500 Kg	6 bar			200
196/PL	500 Kg	6 bar	1,5 KW	400V • 50HZ	230
196/PL-SP	500 Kg	6 bar	1,5 KW	400V • 50HZ	220

 Potenza motore • Motor power • Puissance moteur • Motorleistung

 Alimentazione pneumatica • Pneumatic feeding • Pression d'alimentation • Benötigter Luftdruck

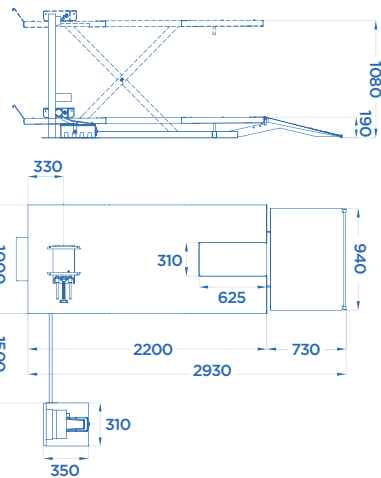

**ART. 196/NS  
CON POMPA IDROPNEUMATICA**

with hydropneumatic pump  
avec pompe hydropneumatique  
mit pneumatischer Pumpe



**ART. 196/MS • 196/MS-SP  
CON POMPA  
ELETTRIDRAULICA**

with electrohydraulic pump  
avec pompe électrohydraulique  
mit elektrohydraulischer Pumpe

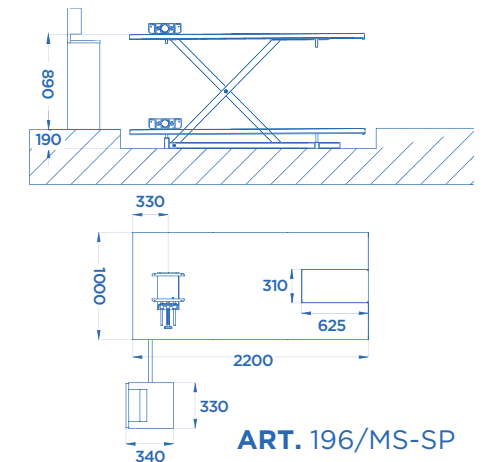
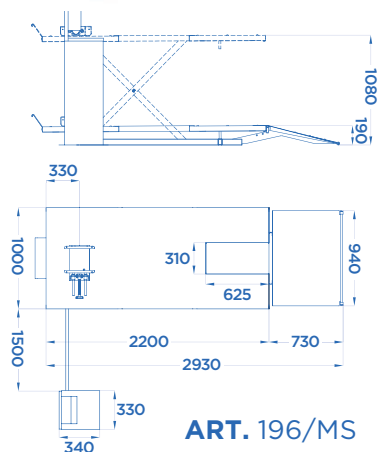

**ART. 196/MS-SP**

**OPTIONAL** Pag. 143

ART.				Motore trifase Three-phase motor Moteur triphasé Netzspannung	
<b>196/MS</b>	500 Kg	6 bar	1,5 KW	400V • 50HZ	315
<b>196/MS-SP</b>	500 Kg	6 bar	1,5 KW	400V • 50HZ	305
<b>196/NS</b>	500 Kg	6 bar			290







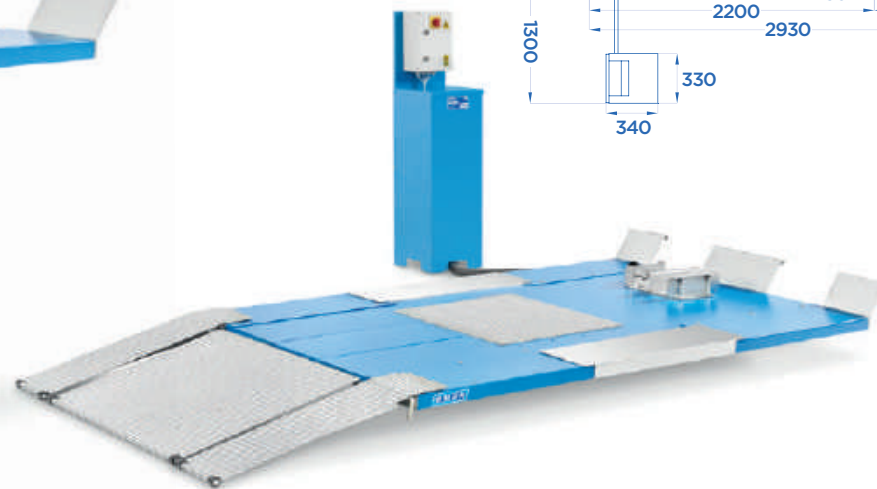
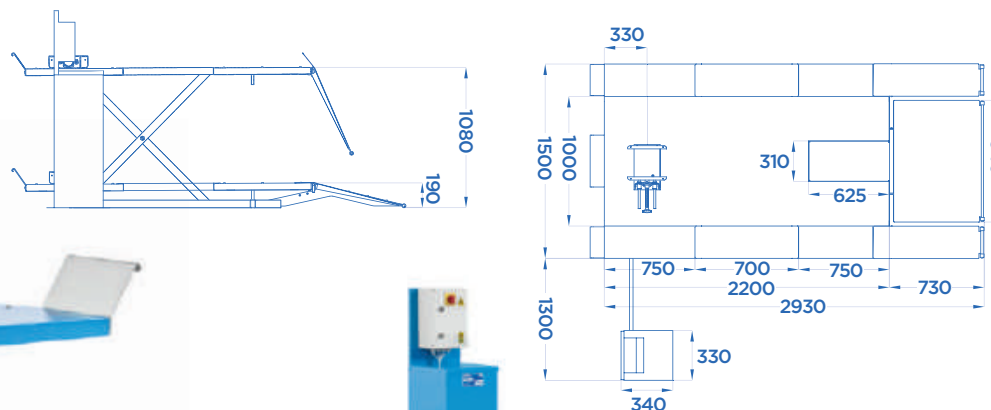

**ART. 196/OS  
 CON POMPA ELETTROIDRAULICA**

with electrohydraulic pump  
 avec pompe électrohydraulique  
 mit elektrohydraulischer Pumpe



**OPTIONAL** Pag. 143

<b>ART.</b>				
<b>196/OS</b>	600 Kg	6 bar	1,5 KW	360
			Motore trifase Three-phase motor Moteur triphasé Netzspannung	
			400V • 50HZ	

 Potenza motore • Motor power • Puissance moteur • Motorleistung  
 Alimentazione pneumatica • Pneumatic feeding • Pression d'alimentation • Benötigter Luftdruck





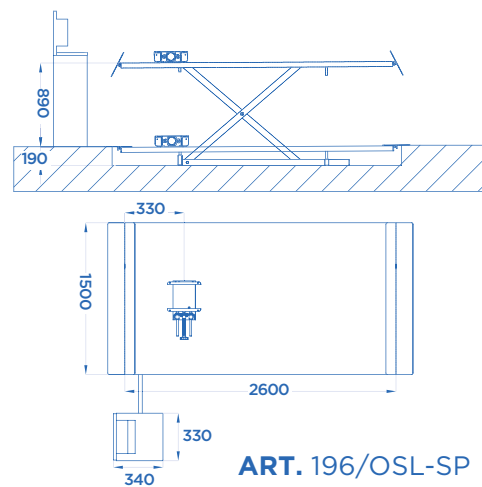
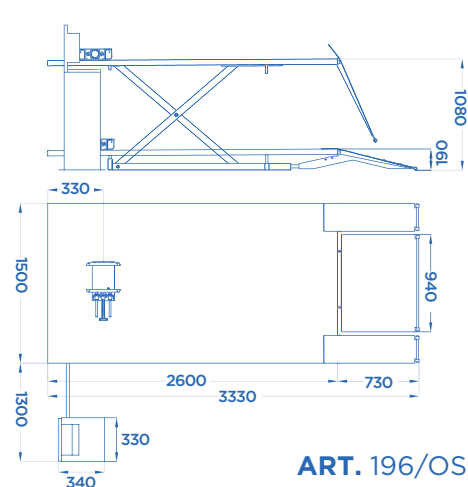

## ART. 196/OSL • 196/OSL-SP CON POMPA ELETTROIDRAULICA

with electrohydraulic pump  
avec pompe électrohydraulique  
mit elektrohydraulischer Pumpe



**OPTIONAL** Pag. 143

ART.				Motore trifase Three-phase motor Moteur triphasé Netzspannung	
<b>196/OSL</b>	600 Kg	6 bar	1,5 KW	400V • 50HZ	410
<b>196/OSL-SP</b>	600 Kg	6 bar			400

 Alimentazione pneumatica • Pneumatic feeding • Pression d'alimentation • Benötigter Luftdruck

 Potenza motore • Motor power • Puissance moteur • Motorleistung



# SOLLEVATORI PER MOTO

## MOTOR-BIKE LIFTS

### ELEVATEURS POUR MOTOS

#### MOTORRAD-HEBEBÜHNEN

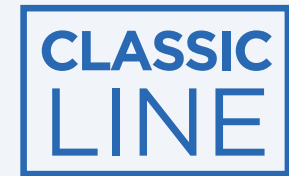

#### TRACCIATO TECNICO COSTRUTTIVO

- Ferma ruota anteriore a sbalzo per agevolare il posizionamento della moto.
- Morsa manuale in versione ribassata di serie su tutti i modelli.
- **La struttura del basamento garantisce massima stabilità e minimo ingombro a terra.**
- Finestra posteriore estraibile per facilitare l'estrazione della ruota (196/A - 196/B).
- Pompa idraulica a pedale ad innesto diretto per ridurre il tempo necessario al sollevamento (196 - 196/A).
- Sistema di sollevamento totalmente pneumatico dotato di cremagliera meccanica ad inserimento automatico (196/B).

#### RELEVÉ TECHNIQUE

- La butée avant facilite le positionnement de la moto même munie d'un chevalet central.
- Etau manuel extra-plate de série sur tous les modèles.
- Ouverture arrière extractible (196/A - 196/B).
- **La structure du soubassement assure une stabilité optimale pour un encombrement au sol réduit au minimum.**
- Pompe hydraulique à pédale à raccord rapide pour un levage encore plus rapide (196 - 196/A).
- Système de levage entièrement pneumatique avec une crémaillère mécanique à raccord automatique (196/B).

#### TECHNICAL AND STRUCTURAL LAY-OUT

- Front stop to make it easier to place the motorbike even those with central stand.
- Low profile vice provided with all models.
- Rear opening to facilitate dismounting of the wheel (196/A - 196/B).
- **The basement structure guarantees the maximum stability for a minimum of space occupied on the ground.**
- Hydraulic foot pump with direct insertion to reduce lifting time (196 - 196/A).
- Completely pneumatic lifting system with a mechanic rack with automatic insertion (196/B).

#### TECHNISCHE UND KONSTRUKTIVE ANGABEN

- Verstellvorrichtung für das Vorderrad, um die Positionierung des Motorrades auf ihrem mittleren Kippständer zu erleichtern.
- Manuell ausgeführte versenkbare Klemme, die serienmäßig eingebaut ist.
- Hinter- herausnehmbar Eröffnung (196/A - 196/B).
- **Grundrahmstruktur, um die maximale Stabilität und die minimale Bauhöhe zu sichern.**
- Hydraulische Fußpumpe mit Direktkupplung, um die Hubzeit zu reduzieren (196 - 196/A).
- Komplett pneumatisches Hubsystem mit mechanischer selbsteinschaltender Zahnstange (196/B).

**ART. 196 • 196/A**  
**CON POMPA IDRAULICA**

with hydraulic pump  
avec pompe hydraulique  
mit Hydraulikpumpe

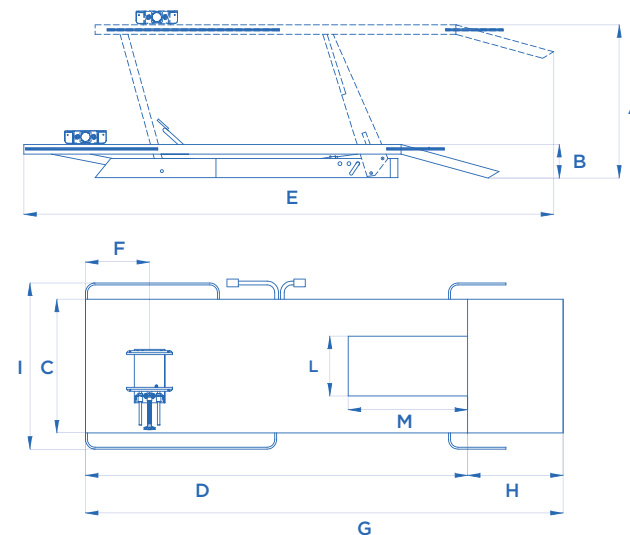

**OPTIONAL** Pag. 143

ART.													
<b>196</b>	500 Kg	770	170	700	2000	2750	330	2500	500	870			165
<b>196/A</b>	500 Kg	770	170	700	2200	2900	330	2700	500	870	300	640	175

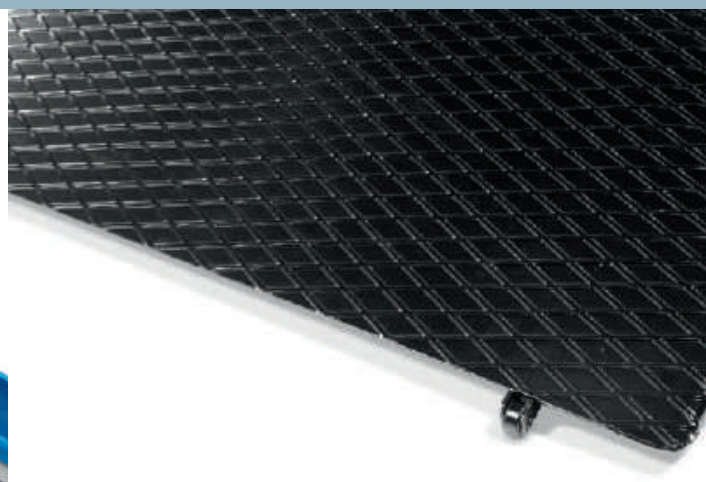







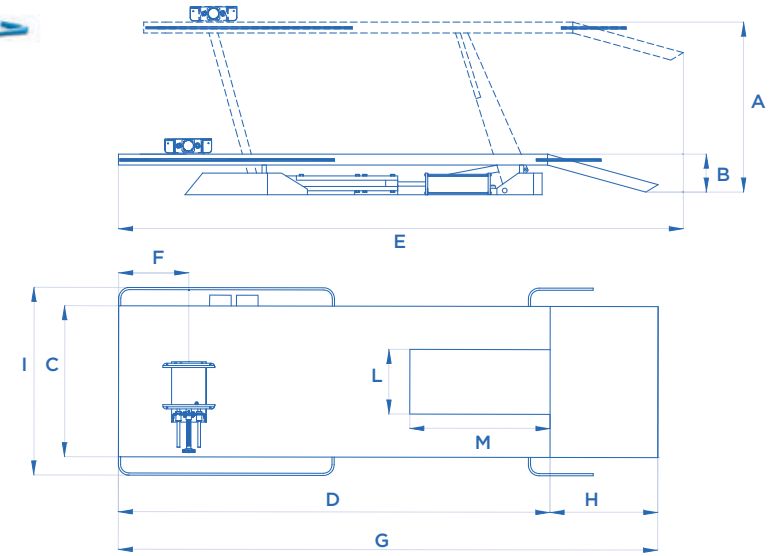







**ART. 196/A**

**ART. 196/B**  
**FUNZIONAMENTO PNEUMATICO**

Pneumatic working implement  
 Fonctionnement pneumatique  
 Pneumatische Funktion



**OPTIONAL** Pag. 143

ART.														
<b>196/B</b>	500 Kg	8 bar	730	190	700	2200	2800	330	2700	500	870	300	640	195

 Alimentazione pneumatica • Pneumatic feeding • Pression d'alimentation • Benötigter Luftdruck

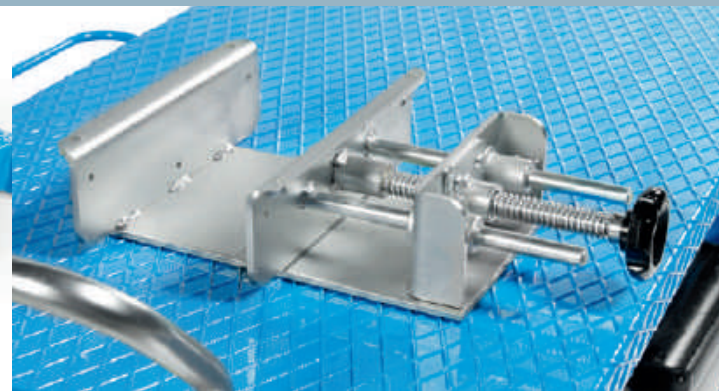

## ACCESSORI EXTRA DOTAZIONE

EXTRA EQUIPMENT • ACCESSOIRES EN OPTION • EXTRA ZUBEHÖR



**ART. 561**  
**CAVALLETTO DI STAZIONAMENTO LIBERA RUOTA**  
**ANTERIORE A BRACCETTI SNODATI**

Stationing stand to free the front wheel with articulated little arms  
 Chevalet de stationnement dégage roue avant avec petits bras articulés  
 Unterstellbock mit Gelenkarmen zum Freiheben des Vorderrades



**ART. 562**  
**CAVALLETTO DI STAZIONAMENTO LIBERA RUOTA**  
**POSTERIORE REGISTRABILE IN ALTEZZA E IN**  
**LARGHEZZA. COMPLETO DI BRACCETTI DI APPOGGIO**  
**E BRACCETTI A FORCELLA**

Free back wheel stationing stand adjustable both in width and in height.  
 Complete with supporting little arms and with fork little arms  
 Chevalet de stationnement dégage roue arrière réglable en hauteur et  
 en largeur. Equipé aussi de petit bras d'appui et de petits bras à fourche  
 Unterstellbock zum Freiheben des Hinterrades in der Breite und in der  
 Höhe verstellbar. Ausgestattet auch mit Tragarmen und Y-Aufnahmen

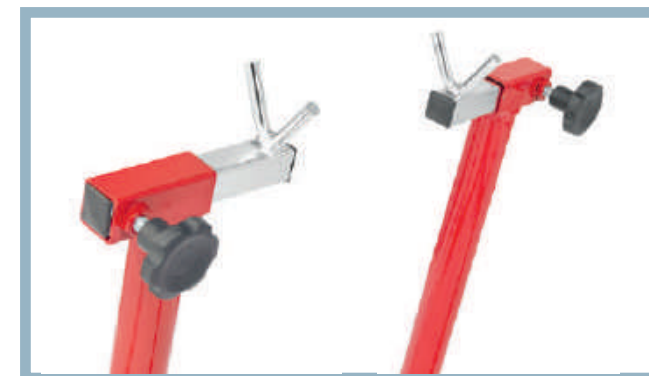

**ART. 562/A**  
**CAVALLETTO DI STAZIONAMENTO LIBERA RUOTA**  
**POSTERIORE REGISTRABILE IN LARGHEZZA. COMPLETO**  
**DI BRACCETTI DI APPOGGIO E BRACCETTI A FORCELLA**

Free back wheel stationing stand adjustable in width.  
 Complete with supporting little arms and with fork little arms  
 Chevalet de stationnement dégage roue arrière réglable en largeur.  
 Equipé de petit bras d'appui et de petits bras à fourche  
 Unterstellbock zum Freiheben des Hinterrades in der Breite verstellbar.  
 Ausgestattet mit Tragarmen und Y-Aufnahmen



## ACCESSORI EXTRA DOTAZIONE

EXTRA EQUIPMENT • ACCESSOIRES EN OPTION • EXTRA ZUBEHÖR

### ART. 566 CAVALLETTO ROTATIVO UNIVERSALE PER LA REVISIONE MOTORI MOTOCICLI COMPLETO DI FLANGIA UNIVERSALE CON ATTACCHI REGOLABILI

Motor-cycle engine overhaul rotative stand complete with universal flange with adjustable attachments

Chevalet rotatif universel pour la révision des moteurs moto. Fourni avec flasque universelle à attaches réglables

Motorrad-Motorreparaturständer mit Universalflansch und einstellbaren Aufnahmen

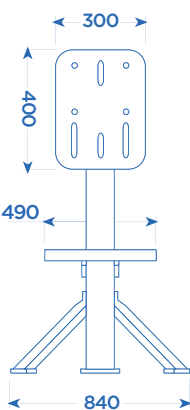
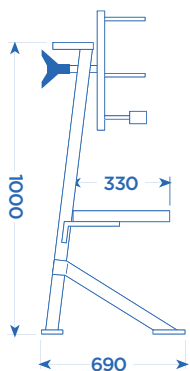

### ART. 560 • 560/A TRAVERSA DI SUPPORTO CON FUNZIONAMENTO A CRICCO, DOTATA DI COPPIA DI BRACCETTI REGOLABILI E REGISTRABILI IN ALTEZZA E DI TAMPONI IN GOMMA

(Al momento dell'ordine precisare il modello di sollevatore sul quale deve essere installato)

Bearing cross-piece with screw-mechanical working, equipped with a couple of adjustable, also in height, little arms and with rubber pads. (When ordering precise the model of the hoist on which you should mount the article)

Traverse de support mécanique à vis, équipée d'une paire de petits bras réglables et ajustables en hauteur. (Indiquer au moment de la commande le modèle de l'élevateur sur lequel vous allez installer l'article)

Hydraulischer Achsfreiheber, ausgestattet mit Gummiauflagen und höhenverstellbaren Tragarmen. (Bei der Bestellung ist es notwendig, das Modell der Hebebühne, wo Sie den Artikel montieren wollen, zu bestimmen)

ART. 560 ✓ TOP LINE

ART. 560/A ✓ CLASSIC LINE

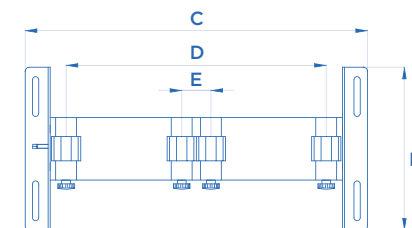
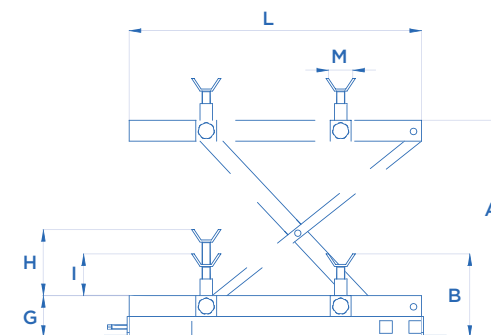

ART.		A mm	B mm	C mm	D mm	E mm	F mm	G mm	H mm	I mm	L mm	M mm
560	250 Kg	350	200	785	410	48	400	102	135	100	555	70
560/A	250 Kg	350	200	785	410	48	400	102	135	100	555	70

## ACCESSORI EXTRA DOTAZIONE

EXTRA EQUIPMENT • ACCESSOIRES EN OPTION • EXTRA ZUBEHÖR

### ART. 563 MORSA PNEUMATICA

Pneumatic vice  
Etau pneumatique  
Pneumatische Felgenklemme

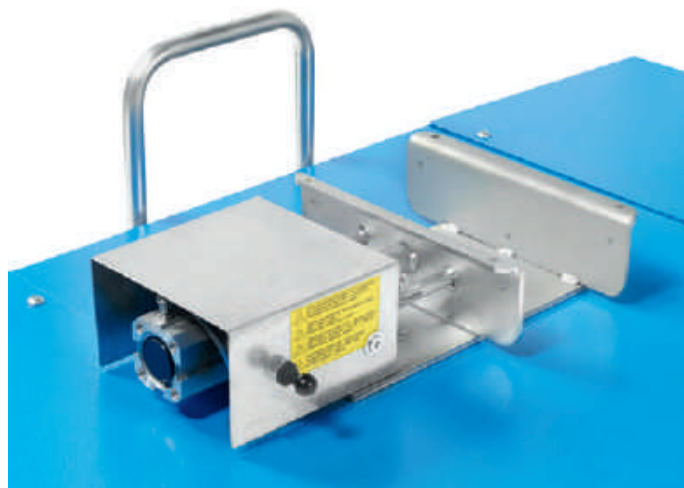

### ART. 563/A MORSA RIBALTABILE BLOCCA RUOTA

Reclining wheel lock vice  
Pince de roue à bascule  
Kippbare Radklemme



### ART. 563/B MORSA A L

L vice  
Etau à L  
L-förmige Klemme

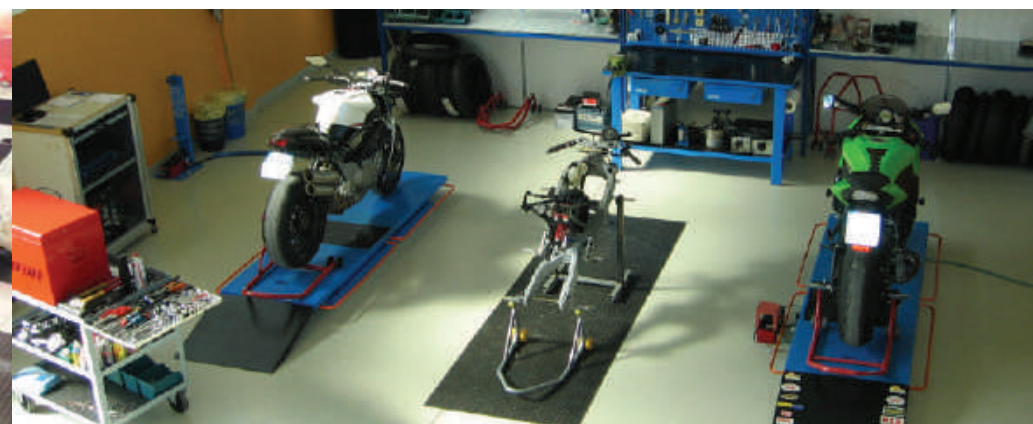
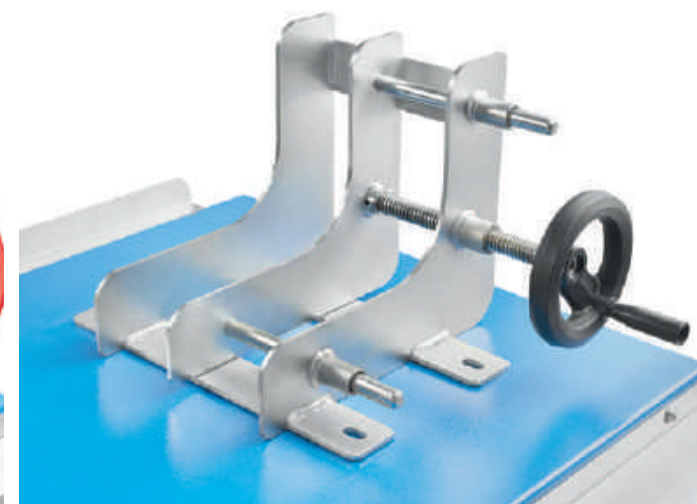

### NOTE

---



---



---



---



---



---



---



---



---



---



---



---



---



---



---



---



---



---



---



---



---



---



---



---

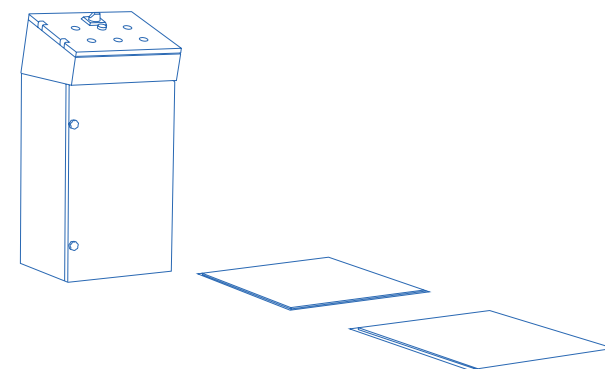

## **PROVAGIOCHI ELETTROIDRAULICI**

ELECTROHYDRAULIC PLAY DETECTORS  
PLAQUES A JEUX ELECTROHYDRAULIQUES  
ELEKTROHYDRAULISCHE GELENKSPIEL-TESTVORRICHTUNG

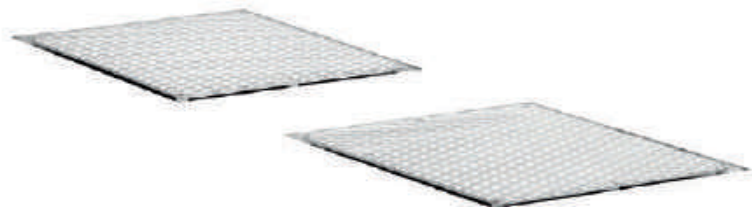

ART. 850/I

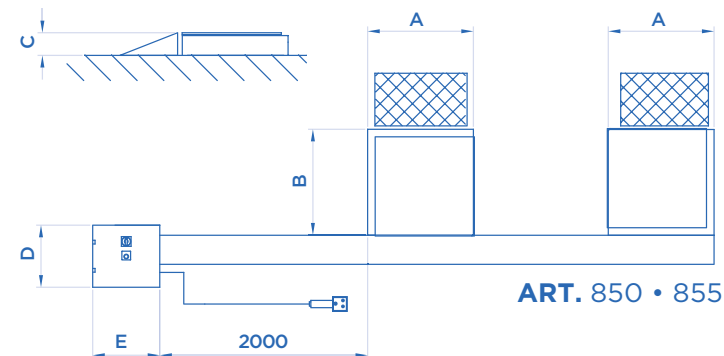

ART. 850 • 855

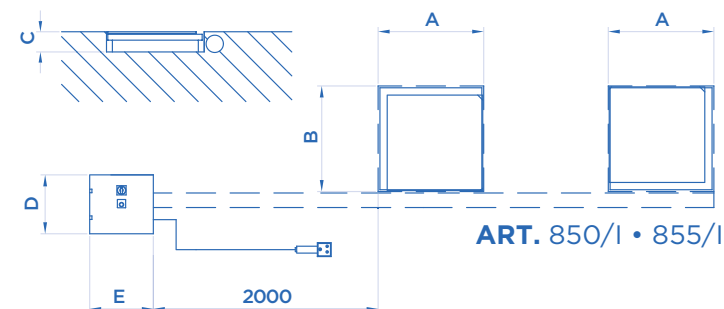

ART. 850/I • 855/I

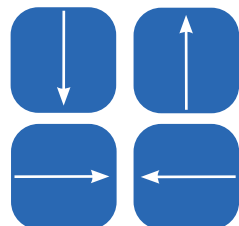
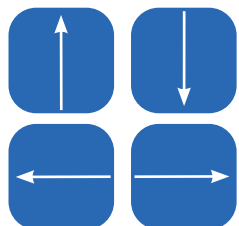

**ART. 855 • 855/I**  
**PROVAGIOCHI A 8 MOVIMENTI**  
 8 movement play detector  
 Plaques à jeux 8 mouvements  
 8 Bewegungen Gelenkspieltester

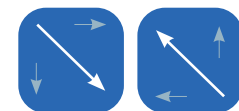
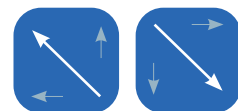

**ART. 850 • 850/I**  
**PROVAGIOCHI A 4 MOVIMENTI**  
 4 movement play detector  
 Plaques à jeux 4 mouvements  
 4 Bewegungen Gelenkspieltester

ART.			Motore trifase Three-phase motor Moteur triphasé Netzspannung	A	B	C	D	E
				mm	mm	mm	mm	mm
850	2500 Kgx2			560	560	120	370	400
850/I	2500 Kgx2	1,5 KW	400V • 50HZ	560	560	120	370	400
855	2500 Kgx2			560	560	130	370	400
855/I	2500 Kgx2			560	560	130	370	400

Potenza motore • Motor power • Puissance moteur • Motorleistung





**HEAVY DUTY**

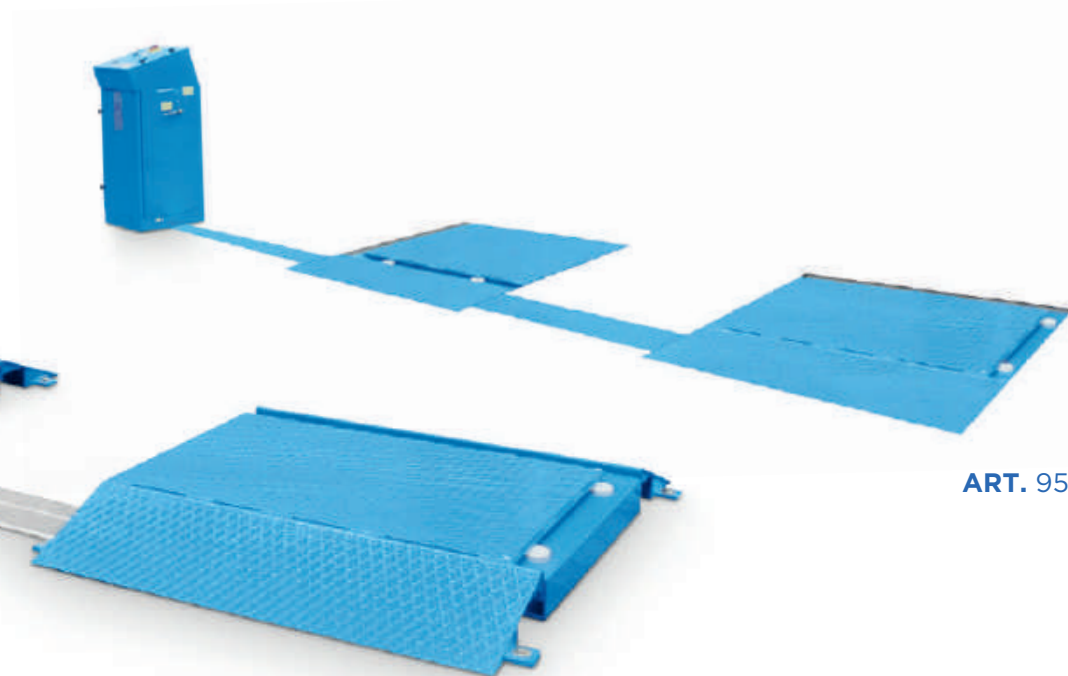
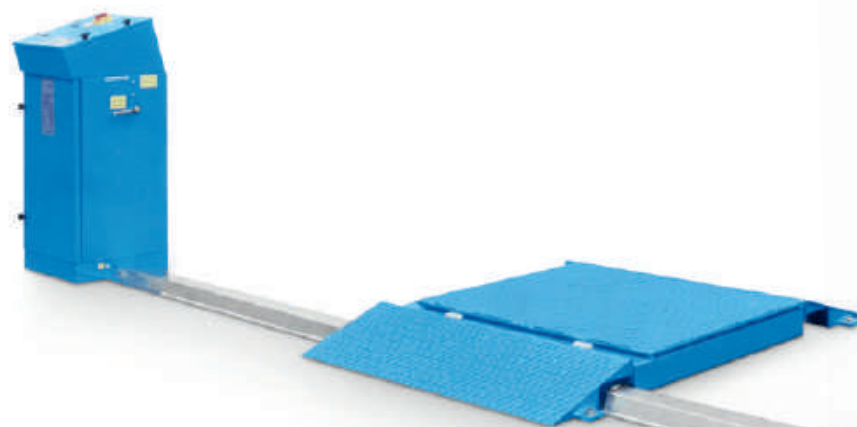
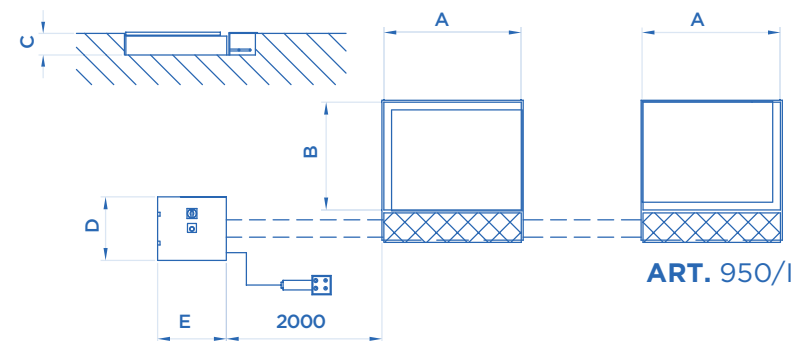
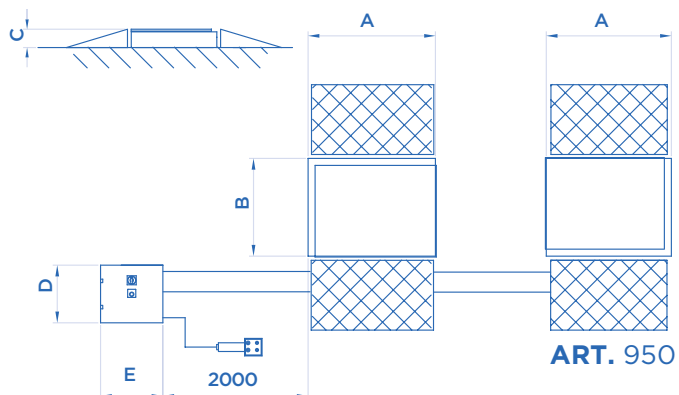

**ART. 950/I**



**PROVAGIOCHI A 4 MOVIMENTI**  
 4 movement play detector  
 Plaques à jeux 4 mouvements  
 4 Bewegungen Gelenkspieltester

**ART. 950**

ART.			Motore trifase Three-phase motor Moteur triphasé Netzspannung	A mm	B mm	C mm	D mm	E mm
<b>950</b>	6750 Kgx2	2,6 KW		950	750	110	370	400
<b>950/I</b>	6750 Kgx2	2,6 KW	400V • 50HZ	950	750	110	370	400

## ACCESSORI EXTRA DOTAZIONE

EXTRA EQUIPMENT • ACCESSOIRES EN OPTION • EXTRA ZUBEHÖR

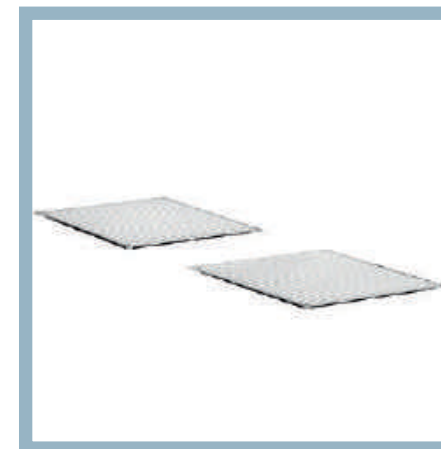

### PULSANTIERA DI COMANDO PROVAGIOCHI WIRELESS

Wireless remote control for play detectors

Platine de commandes pour plaque à jeux sans fil

Wireless-fernsteuerung für gelenkspieltester

**ART. 856**



ART. 850 • 850/I • 950 • 950/I

**ART. 856/A**



ART. 855 • 855/I



### PULSANTIERA DI COMANDO PROVAGIOCHI WIRELESS

La pulsantiera è dotata di un innovativo sistema di attivazione piezoelettrica il quale permette di poter sempre e in ogni caso attivare il provagiochi anche a batteria completamente scarica! Lo stesso sistema è poi equipaggiato di lampada a led con accensione a movimento e viene fornito di tappetino ad induzione per la ricarica della batteria, necessaria per il solo funzionamento della lampada a led. Con questo strumento sarà più facile e più sicuro controllare i giochi dei mezzi e muoversi attorno ai veicoli senza lo spiacevole ingombro del cavo elettrico.

### WIRELESS REMOTE CONTROL FOR PLAY DETECTORS

The remote control works through piezoelectric system, which allows the activation of the play detector in every moment, even when the battery is completely discharged! This item is also equipped with a LED lamp with a movement sensor and an induction mat to charge the battery, which is dedicated to the LED lamp only. Checking vehicle plays has never been so easy and secure, and you can move around the lift without bothering about cables.

### PLATINE DE COMMANDES POUR PLAQUE À JEUX SANS FIL

La platine fonctionne sur un système innovant d'activation piézoélectrique qui permet d'actionner les plaques à jeux même quand les batteries sont complètement à plat! Dotée de lampe à led avec détecteur de mouvement et d'un tapis à induction pour recharger la batterie, uniquement consacrée à la lampe à led. Un outil qui facilite le contrôle des jeux en toute sécurité, et qui consent de se déplacer en toute liberté autour du véhicule sans s'empêtrer dans les câbles.

### WIRELESS-FERNSTEUERUNG FÜR GELENK-SPIELTESTER

Die Fernsteuerung ist mit einem innovativen System zur piezoelektrischen Aktivierung ausgestattet, das es ermöglicht, den Gelenkspieltester jederzeit und unter allen Bedingungen zu aktivieren, auch bei völlig entladener Batterie! Das gleiche System verfügt außerdem über eine LED-Lampe mit Bewegungssensor und wird mit einer Induktionsmatte zum Aufladen der Batterie geliefert, die nur für die Funktion der LED-Lampe notwendig ist. Mit diesem Gerät ist es einfacher und sicherer, die Spiele zu kontrollieren und sich um die Fahrzeuge herum zu bewegen, ohne vom Stromkabel behindert zu werden.



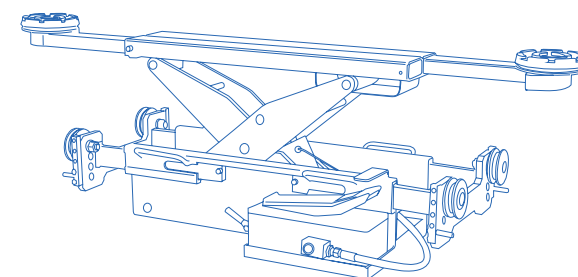

## **TRAVERSE DI SOLLEVAMENTO**

JACKING BEAMS  
TRAVERSES DE LEVAGE  
SCHERENHEBER

Made in Italy 



**TOP  
LINE**

✓ **SERIE 400**  
✓ **SERIE 800**



**ART. 459**

**ART. 459 • 459/A**

**TRACCIATO TECNICO COSTRUTTIVO**

- Traversa di sollevamento per auto e veicoli commerciali.
- Altezza chiusa molto ridotta per sollevare agevolmente vetture dalla carrozzeria ribassata.
- Staffa meccanica di stazionamento a garanzia di massima sicurezza.
- Valvola di massima pressione per impedire carichi superiori alla portata nominale.
- **Set di supporti in gomma e coppia di distanziali forniti di serie.**
- Rulli di guida in acciaio dotati di cuscinetti a sfera.
- Comando di discesa "uomo presente".
- **Art. 459:** Traversa con pompa idropneumatica.
- **Art. 459/A:** Traversa con pompa a mano.

**TECHNICAL AND STRUCTURAL LAY-OUT**

- Lifting crosspiece for cars and vans.
- Low profile when closed to lift low profile vehicles.
- Mechanical parking bracket to guarantee the maximum safety.
- Maximum pressure valve to avoid loads exceeding the nominal capacity.
- **Delivered with a set of rubber supports and a pair of spacers.**
- Steel-made driving rolls with ball-bearings.
- "Man-standing-by" lowering control.
- **Art. 459:** Crosspiece with a hydro-pneumatic pump.
- **Art. 459/A:** Crosspiece with a hand-pump.

**ACCESSORI EXTRA DOTAZIONE**

EXTRA EQUIPMENT • ACCESSOIRES EN OPTION • EXTRA ZUBEHÖR

**ART. A459  
ADATTATORI**

Adaptors  
Adaptateurs  
Adapter

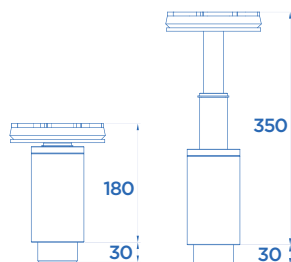

**KIT X2**



## RELEVÉ TECHNIQUE

- Traverse de levage pour voitures et utilitaires.
- Hauteur réduite en position fermée pour la prise sous coque des voitures surbaissées.
- Crémaillère de stationnement pour une sécurité optimale.
- Soupape de pression maximale pour éviter tout danger de surcharge (charge supérieure à la capacité déclarée).
- **Kit de rallonges et supports en caoutchouc fourni.**
- Rouleaux de guide en acier sur roulements à billes.
- Commande de descente "homme mort".
- **Art. 459:** Traverse avec pompe hydropneumatique.
- **Art. 459/A:** Traverse avec pompe manuelle.

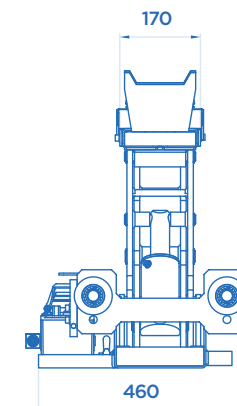
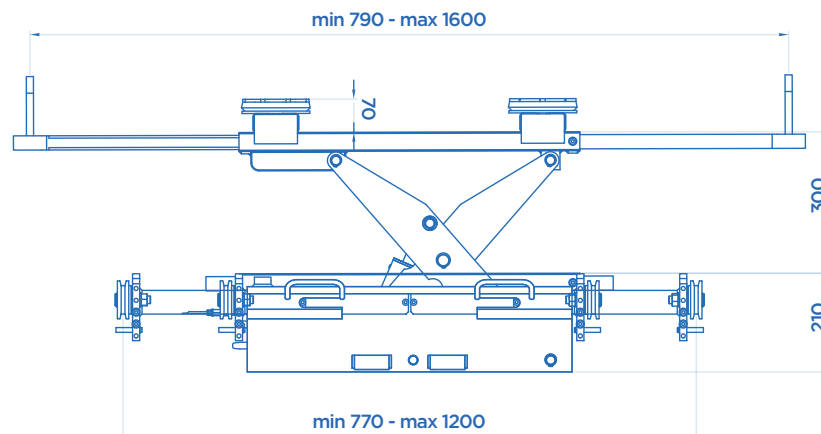

## TECHNISCHE UND KONSTRUKTIVE ANGABEN

- Achsfreiheber für das Heben von Autos und Nutzfahrzeuge.
- Ermäßigte Höhe, wenn geschlossen, um Fahrzeuge mit tiefergelegter Karosserie einfach anzuheben.
- Mechanische Zahnstange, um die maximale Sicherheit zu sichern.
- Max. Drückventil, um das Heben von Laduns über die Nominallastkapazität zu verbieten.
- **Mit einem Kit von Gummiauflagen und einem Paar von Distanzstücke.**
- Aus Stahl gemachte Führungsrollen mit Kugellagern.
- „Totmann-Absenksteuerung“.
- **Art. 459:** Achsfreiheber mit einer hydropneumatische Pumpe.
- **Art. 459/A:** Achsfreiheber mit einer Handpumpe.



ART. 459/A



ART.		
459	2500 kg	8 bar
459/A	2500 kg	

 Alimentazione pneumatica • Pneumatic feeding  
• Pression d'alimentation • Benötigter Luftdruck

**ART. 203**



 **SERIE 400**

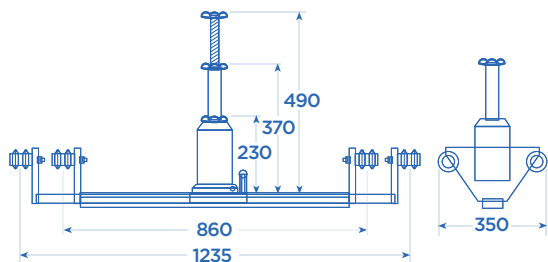
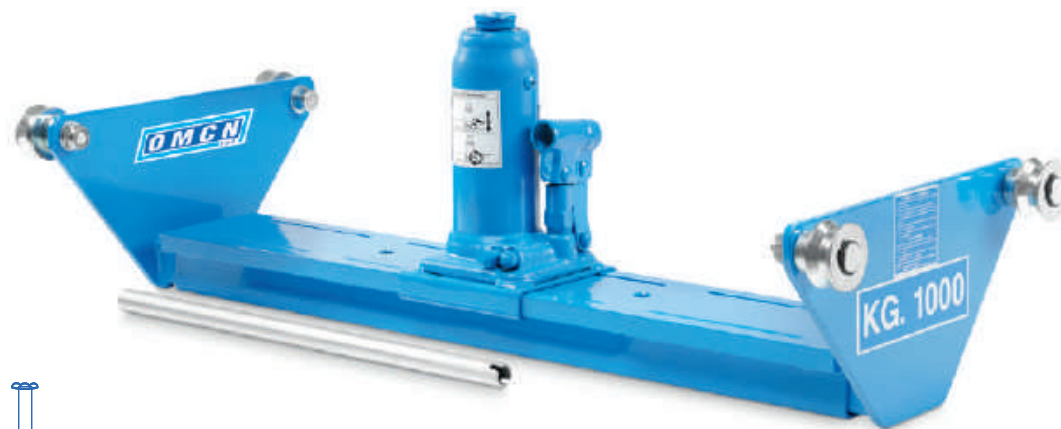

**ART.**   
**203** | 1000 kg

**ART. 450**



 **SERIE 400**

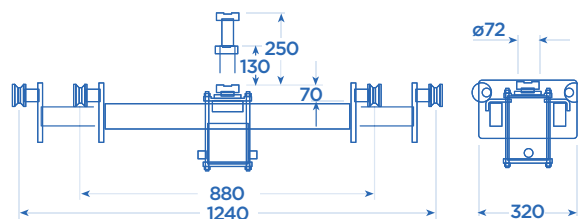

**ART.**    
**450** | 1000 kg | 10 bar

 Alimentazione pneumatica • Pneumatic feeding • Pression d'alimentation • Benötigter Luftdruck

## ART. 450/A



✓ **SERIE 400**

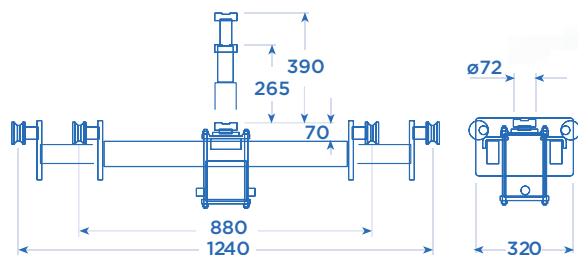

Alimentazione pneumatica • Pneumatic feeding • Pression d'alimentation • Benötigter Luftdruck



## ART. 460



ART.



**460** | 2500 kg | 8 bar

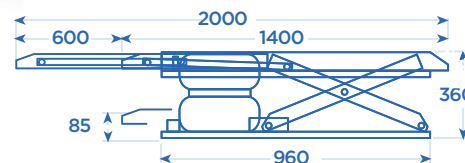
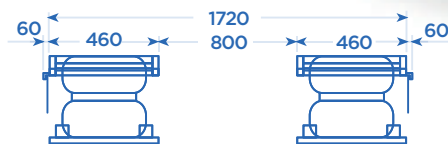

Alimentazione pneumatica • Pneumatic feeding • Pression d'alimentation • Benötigter Luftdruck

## ART. 460

### TRACCIATO TECNICO COSTRUTTIVO

- Sollevatore interamente pneumatico.
- Struttura portante a forbice robusta e compatta, con prolunga estensibile porta tamponi.
- Sollevatore a basso profilo per la massima facilità di accesso.
- Valvola di sicurezza contro i sovraccarichi.
- Velocità di discesa controllata.
- Dotato di dispositivo meccanico di sicurezza.

### TECHNICAL AND STRUCTURAL LAY-OUT

- Completely pneumatic lift.
- Sturdy and compact scissor carrying structure, with holder-pads extension.
- Low profile lift for a very easy going up.
- Overload safety valve.
- Checked descent speed.
- Equipped with a safety mechanical device.

### RELEVÉ TECHNIQUE

- Elévateur complètement pneumatique.
- Structure portante à ciseaux robuste et compacte, avec rallonge extensible porte-tampons.
- Elévateur surbaissé pour faciliter la montée des véhicules.
- Soupape de sûreté contre les surcharges.
- Vitesse de descente contrôlée.
- Equipé avec un dispositif mécanique de sûreté.

### TECHNISCHE UND KONSTRUKTIVE ANGABEN

- Scherenheber mit pneumatischem Antrieb.
- Stabiles Scherentraggestell mit verstellbaren Tragarmverlängerungen.
- Scherenheber mit niedrigem Gestellprofil zur Einsatzerleichterung.
- Überdruckventil für den Überlastungsschutz.
- Sicherheitsventil für die Überwachung der Absenkgeschwindigkeit.
- Mechanische Sicherheitsvorrichtung gemäß der Europäischen Norm.

**HEAVY  
DUTY**

✓ ART. 405 • 406 • 407  
✓ SERIE 900



ART. 458/B

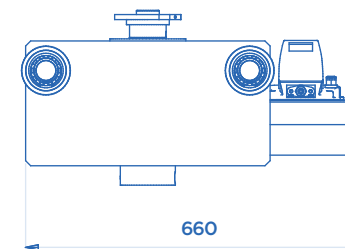
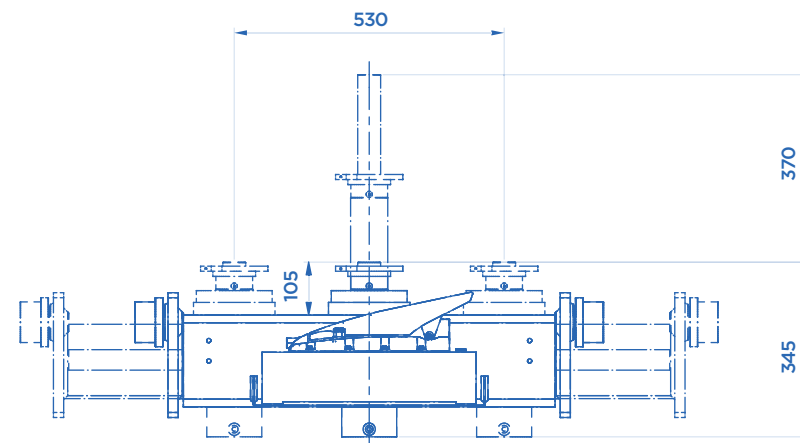

ART. 458/B | 5000 kg | 8 bar

Alimentazione pneumatica • Pneumatic feeding • Pression d'alimentation • Benötigter Luftdruck

#### TRACCIATO TECNICO COSTRUTTIVO

- Dotata di un singolo cilindro traslabile lateralmente.
- Azionamento tramite pompa idropneumatica
- **Grande corsa di sollevamento (370 mm).**
- Valvola di massima pressione per impedire carichi superiori alla portata nominale.
- Rulli di guida in acciaio dotati di cuscinetti a sfera.
- Comando di discesa "uomo presente".

#### TECHNICAL AND STRUCTURAL LAY-OUT

- One laterally movable cylinder.
- Hydro-pneumatic pump.
- **Long lifting stroke (370 mm).**
- Maximum pressure valve to avoid loads exceeding the nominal capacity.
- Steel-made driving rolls with ball-bearings.
- "Man-standing-by" lowering controls.

#### RELEVÉ TECHNIQUE

- Vérin unique mobile (déplacement latéral).
- Fonctionnement à pompe hydropneumatique.
- **Longue course de levage (370 mm).**
- Soupape de sécurité pour éviter tout danger de surcharge (charge supérieure à la capacité déclarée).
- Rouleaux de guide en acier sur roulements à billes.
- Commande de descente "homme mort".

#### TECHNISCHE UND KONSTRUKTIVE ANGABEN

- Mit einem seitensbewegbaren Zylinder.
- Steuerung ausführbar dank einer hydropneumatischen Pumpe.
- **Lang Kolbenhub (370 mm).**
- Max. Drückventil um das Heben von Ladung über die Nominallastkapazität zu verbieten.
- Aus Stahl gemachte Führungsrollen mit Kugellagern.
- „Totmann-Absenksteuerung“.

**HEAVY  
DUTY**

**ART. 458/A** ✓ **SERIE 900**  
**ART. 458/C** ✓ **ART. 406 • 407**

ART.		
<b>458/A</b>	13500 kg	8 bar
<b>458/C</b>	10000 kg	8 bar

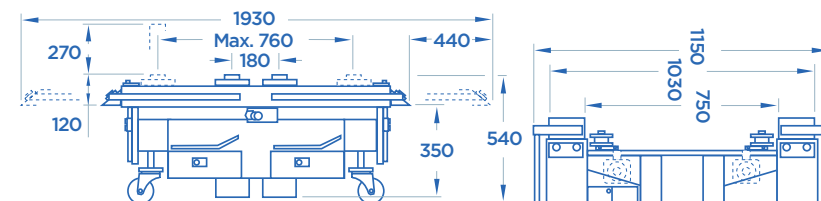

**ART. 458/A**



**ART. 458/A**

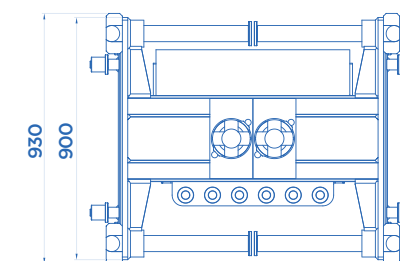
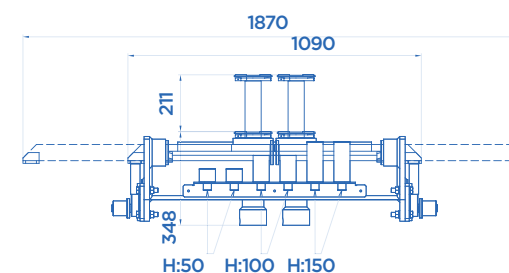

**ART. 458/C**

 Alimentazione pneumatica • Pneumatic feeding • Pression d'alimentation • Benötigter Luftdruck

#### TRACCIATO TECNICO COSTRUTTIVO

- Dotate di due cilindri traslabili lateralmente.
- Azionamento tramite due pompe idropneumatiche.
- Possibilità di controllare i due cilindri in modo indipendente uno dall'altro.
- Grande corsa di sollevamento.
- **Set di supporti a U forniti di serie** (Art. 458/A).
- **Dotata di 4 ruote pivotanti per una facile movimentazione senza accessori aggiuntivi** (Art. 458/A).
- **Set di prolunghe di varie altezze fornite di serie** (Art. 458/C).
- Valvola di massima pressione per impedire carichi superiori alla portata nominale.
- Comando di discesa "uomo presente"

#### TECHNICAL AND STRUCTURAL LAY-OUT

- Two laterally movable cylinders.
- Two hydro-pneumatic pumps.
- Both cylinders can move separately.
- Long lifting stroke.
- **Delivered with a set of U-supports** (Art. 458/A).
- **Equipped with four pivot wheels for an easy move without any additional accessories** (Art. 458/A).
- **Delivered with a set of extensions of different heights** (Art. 458/C).
- Maximum pressure valve to avoid loads exceeding the nominal capacity.
- Man-standing-by lowering control.

#### RELEVÉ TECHNIQUE

- Deux vérins mobiles (déplacement latéral).
- Fonctionnement via deux pompes hydro-pneumatiques.
- Vérins indépendants l'un de l'autre.
- Longue course de levage.
- **Paire de supports à fourche fournie** (Art. 458/A).
- **4 roues pivotantes de série pour faciliter les déplacements** (Art. 458/A).
- **Kit de rallonges de différentes hauteurs fourni** (Art. 458/C).
- Soupape de sécurité pour éviter tout danger de surcharge (charge supérieure à la capacité déclarée).
- Commande de descente "homme mort".

#### TECHNISCHE UND KONSTRUKTIVE ANGABEN

- Mit zwei seitenbewegbaren Zylindern.
- Steuerung ausführbar dank zwei hydropneumatischen Pumpen.
- Unabhängig-kontrollierbare Zylinder.
- Lang Kolbenhub.
- **Mit einem Kit von U-Auflagen** (Art. 458/A).
- **Mit vier lenkbaren Rädern für eine einfache Bewegung ohne weiteres Zubehör** (Art. 458/A).
- **Mit einem Kit von Verlängerungen mit verschiedenen Höhen** (Art. 458/C).
- Max. Drückventil um das Heben von Ladung über die Nominallastkapazität zu verbieten.
- „Totmann-Absenksteuerung“.



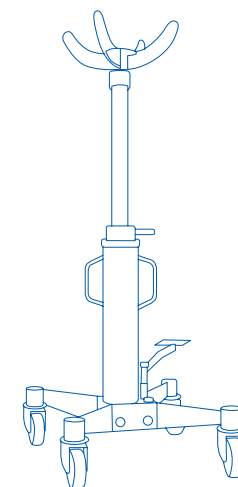

**SOLLEVATORI IDRAULICI  
DA FOSSA E SOTTOPONTE**

HYDRAULIC TRANSMISSION JACKS  
VERINS DE FOSSE HYDRAULIQUES  
HYDRAULISCHE GETRIEBEBEHER

Made in Italy 





ART. SIF1/A/73



ART. SIF2/73



ART. SIF4/73



#### TRACCIATO TECNICO COSTRUTTIVO

- Stelo in acciaio speciale rettificato e cromato.
- Ruote di grandi dimensioni montate su cuscinetti per la massima manovrabilità.
- Valvola di protezione contro i sovraccarichi.
- Comando di discesa a velocità controllata "uomo presente".
- Pompa a due velocità per garantire un avvicinamento rapido (SIF4 - SIF5 - SIF6).
- Ruote rientranti con l'alloggiamento di un peso pari a 750 Kg (SIF5 - SIF6).

#### TECHNICAL AND STRUCTURAL LAY-OUT

- Shafts are made of special chrome-plated ground steel.
- Wheels of big dimensions mounted on bearings to guarantee the maximum manoeuvrability.
- Safety valve to avoid any possible overload.
- "Man standing-by" descent control device with a controlled speed.
- 2-speed pump, including a fast approaching speed (SIF4 - SIF5 - SIF6).
- Wheels re-enter in their housing under a 750 Kg load (SIF5 - SIF6).

#### RELEVÉ TECHNIQUE

- Vérin en acier spécial, rectifié et chromé.
- Roues de grandes dimensions montées sur roulements pour faciliter les déplacements.
- Soupape de sécurité anti-surcharge.
- Commande de descente à vitesse contrôlée de type "homme-mort".
- Pompe à double vitesse pour une approche rapide (SIF4 - SIF5 - SIF6).
- A partir de 750 kg de charge, les roues se rétractent dans leur logement (SIF5 - SIF6).

#### TECHNISCHE UND KONSTRUKTIVE ANGABEN

- Kolben aus verchromtem und schleifendem Spezialstahl.
- Räder mit großem Durchmesser, die auf der Rollen montiert sind, um die maximale Wendigkeit zu sichern.
- Überlastventil gegen jeder Überlastung.
- Totmann -Abstiegskontrolle mit einer kontrollierten Geschwindigkeit.
- Zwei- Geschwindigkeitspumpe, um eine geschwinde Annäherung zu sichern (SIF4 - SIF5 - SIF6).
- Mit einfedernden Rädern mit einem Last von 750 Kg (SIF5 - SIF6).





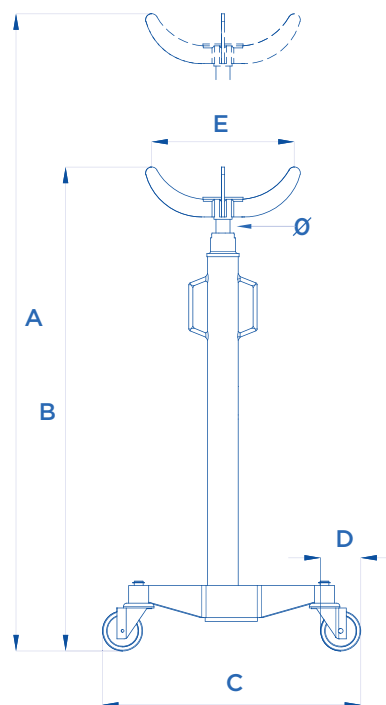





ART. SIF6/73



OPTIONAL Pag. 164

ART.		A  mm	B  mm	C  mm	D  mm	E  mm	Ø  mm	 KG
<b>SIF1/73</b>	250 Kg	2090	1240	635x635	80	270	22	22
<b>SIF1/A/73</b>	400 Kg	2090	1300	635x635	80	270	24	27
<b>SIF2/A/73</b>	600 Kg	1960	1180	520x520	80	320	30	37
<b>SIF2/73</b>	1000 Kg	1990	1190	530x530	100	325	35	40
<b>SIF3/73</b>	1500 Kg	2020	1220	540x540	100	340	45	60
<b>SIF4/73</b>	2500 Kg	2220	1350	550x550	100	355	50	85
<b>SIF5/73</b>	6000 Kg	2215	1315	720x720	100	360	60	112
<b>SIF6/73</b>	10.000 Kg	2215	1315	720x720	100	360	60	116

**OPTIONAL** Pag. 164

ART.		 A mm	 B mm	 C mm	 D mm	 E mm	 Ø mm	 KG
<b>SIF7/73</b>	800 Kg	1880	920	530x530	100	320	30	48
<b>SIF8/73</b>	1500 Kg	1960	960	550x550	100	325	35	58
<b>SIF10/73</b>	4000 Kg	1900	930	550x550	100	340	45	95

**ART. SIF10/73**

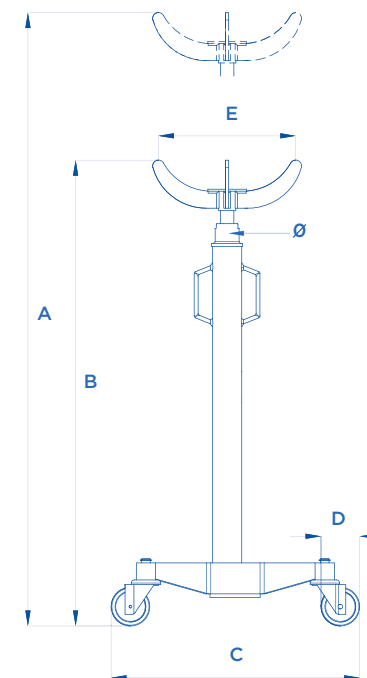
**ART. SIF7/73**

**TRACCIATO TECNICO COSTRUTTIVO**

- Cilindro telescopico a due stadi.
- Steli in acciaio speciale rettificato e cromato.
- Ruote di grandi dimensioni montate su cuscinetti per la massima manovrabilità.
- Valvola di protezione contro i sovraccarichi.
- Comando di discesa a velocità controllata "uomo presente".
- Pompa a due velocità per garantire un avvicinamento rapido (SIF8 - SIF10).

**TECHNICAL AND STRUCTURAL LAY-OUT**

- Two-stage telescopic cylinder.
- Shafts are made of special chrome-plated ground steel.
- Wheels of big dimensions mounted on bearings to guarantee the maximum manoeuvrability.
- Safety valve to avoid any possible overload.
- "Man standing-by" descent control device with a controlled speed.
- 2-speed pump, including a fast approaching speed (SIF8 - SIF10).

**RELEVÉ TECHNIQUE**

- Vérin télescopique à deux files.
- Vérin en acier spécial, rectifié et chromé.
- Roues de grandes dimensions montées sur roulements pour faciliter les déplacements.
- Soupape de sécurité anti-surcharge.
- Commande de descente à vitesse contrôlée de type "homme-mort".
- Pompe à double vitesse pour une approche rapide (SIF8 - SIF10).

**TECHNISCHE UND KONSTRUKTIVE ANGABEN**

- 2-Stufig zusammenschiebbar Zylinder.
- Kolben aus verchromtem und schleifendem Spezialstahl.
- Räder mit großem Durchmesser, die auf der Rollen montiert sind, um die maximale Wendigkeit zu sichern.
- Überlastventil gegen jeder Überlastung.
- Totmann -Abstiegskontrolle mit einer kontrollierten Geschwindigkeit.
- Zwei- Geschwindigkeitspumpe, um eine geschwinde Annäherung zu sichern (SIF8 - SIF10)



ART. SIF6/73 IP

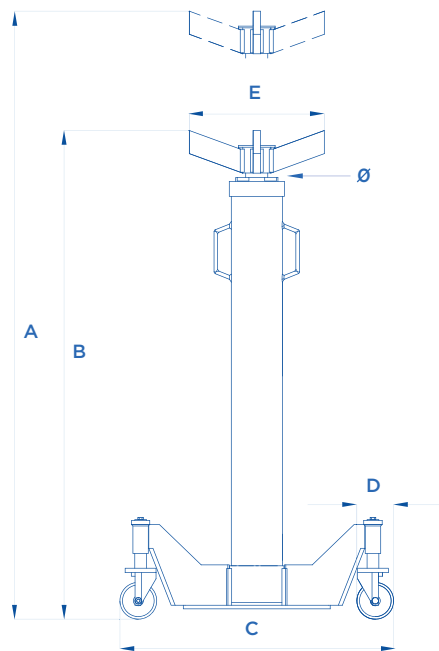

OPTIONAL Pag. 164



CE Made in Italy

ART.			A mm	B mm	C mm	D mm	E mm	Ø mm	KG
<b>SIF5/73 IP</b>	6000 Kg	8-10 bar	2215	1315	720x720	100	360	60	125
<b>SIF6/73 IP</b>	10000 Kg	8-10 bar	2215	1315	720x720	100	360	60	130

Alimentazione pneumatica • Pneumatic feeding • Pression d'alimentation • Benötigter Luftdruck

### TRACCIATO TECNICO COSTRUTTIVO

- Sollevatore a funzionamento oleopneumatico.
- Avvicinamento ultra rapido grazie alla pompa a due velocità.
- Stelo in acciaio speciale rettificato e cromato.
- Ruote di grandi dimensioni montate su cuscinetti per la massima manovrabilità.
- Valvola di protezione contro i sovraccarichi.
- Comando di discesa a velocità controllata "uomo presente".
- Ruote rientranti con l'alloggiamento di un peso pari a 750 Kg.

### TECHNICAL AND STRUCTURAL LAY-OUT

- Air-hydraulic jack.
- Super fast approaching speed thanks to a two-speed pump.
- Shaft made of special chrome-plated ground steel.
- Wheels of big dimensions mounted on bearings to guarantee the maximum manoeuvrability.
- Safety valve to avoid any possible overload.
- "Man standing-by" descent control device with a controlled speed.
- Wheels re-enter in their housing under a 750 Kg load.

### RELEVÉ TECHNIQUE

- Vérin de fosse à fonctionnement oléopneumatique.
- Vitesse d'approche ultra-rapide grâce à une pompe à 2-vitesses.
- Vérin en acier spécial, rectifié et chromé.
- Roues de grandes dimensions montées sur roulements pour faciliter les déplacements.
- Soupape de sécurité anti-surcharge.
- Commande de descente à vitesse contrôlée
- A partir de 750 kg de charge, les roues se rétractent dans leur logement.

### TECHNISCHE UND KONSTRUKTIVE ANGABEN

- Hydropneumatische Hebebühne.
- Mit einer sehr geschwinden Annäherung dank einer 2-Geschwindigkeitspumpe.
- Kolben aus verchromtem schleifendem Spezialstahl.
- Räder mit großem Durchmesser, die auf der Rollen montiert sind, um die maximale Wendigkeit zu sichern.
- Überlastventil gegen jeder Überlastung.
- Totmann -Abstiegskontrolle mit einer kontrollierten Geschwindigkeit.
- Mit einfedernden Rädern mit einem Last von 750 Kg.

## ACCESSORI EXTRA DOTAZIONE

EXTRA EQUIPMENT • ACCESSOIRES EN OPTION • EXTRA ZUBEHÖR

### CULLE UNIVERSALI

Universal cradles  
Berceaux universels  
Universalplatten

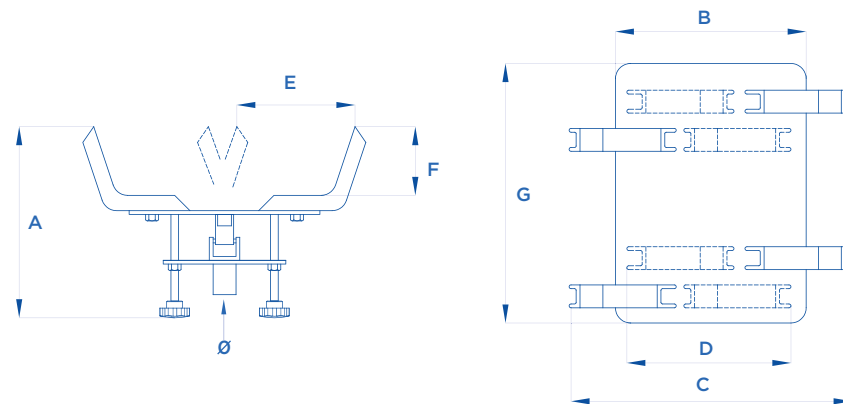

ART.		A mm	B mm	C mm	D mm	E mm	F mm	G mm	∅ mm	KG
15/73	250 kg	360	250	525	420	80	100	340	30	15

ART. 15/73

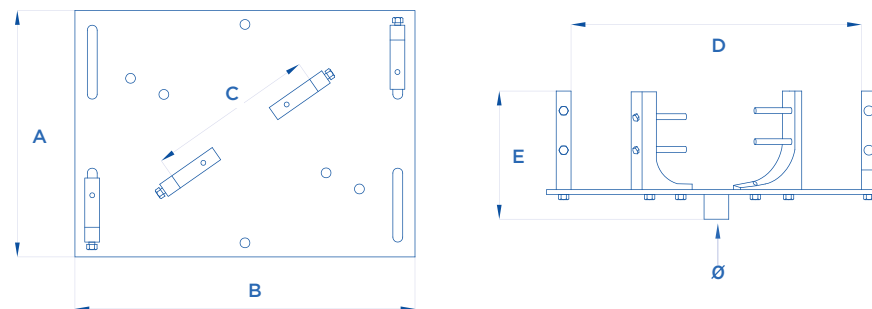

ART.		A mm	B mm	C mm	D mm	E mm	∅ mm	KG
234	600 kg	500	690	450	610	330	60	30

ART. 234

## ART. SIF/XR

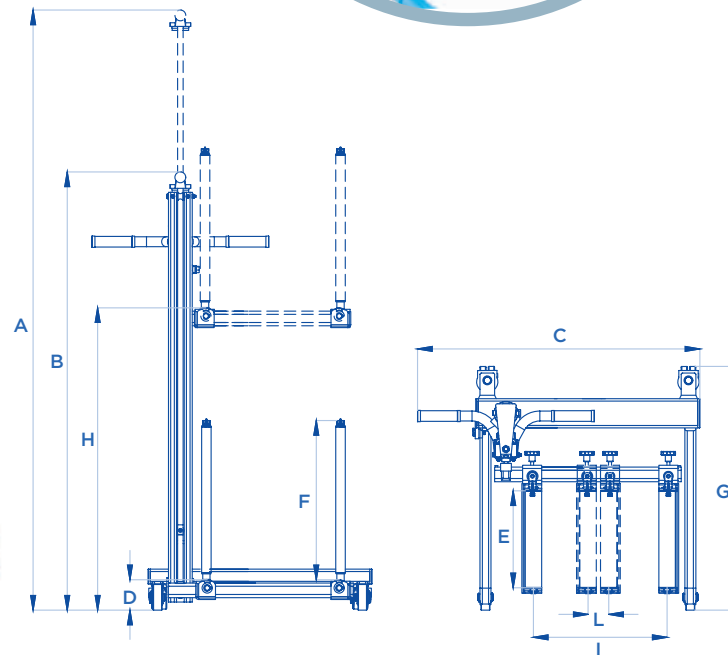

ART.



A mm

B mm

C mm

D mm

E mm

F mm

G mm

H mm

I mm

L mm



SIF/XR

100 kg

2080

1230

770

100

295

425

730

940

355

45

50

## ART. SIF/XR • SIF/XR IP

Sollevatori creati per smontare e rimontare in tutta sicurezza ruote di autovetture, veicoli commerciali e SUV posti su ponti sollevatori a due colonne o doppia forbice.

L'azionamento è a pedale per l'Art. SIF/XR e pneumatico per l'Art. SIF/XR IP.

I rulli in materiale speciale sono regolabili in larghezza ed eccentrici per permettere il rapido posizionamento dei bulloni.

Right article to disassemble and install wheels of cars, commercial vehicles and SUV placed on 2 post autolifts or twin-scissor hoists. Foot control for Art. SIF/XR and pneumatic control for Art. SIF/XR IP. Rollers in special material are recordable in width and outlying, to allow quick wheelnuts positioning.

Idéal pour le démontage et remontage des roues de voitures, véhicules commerciaux et tous-terrains placés sur pont élévateur à 2 colonnes ou double ciseaux. Commande à pédale pour Art. SIF/XR et commande pneumatique pour Art. SIF/XR IP. Les rouleaux dans un matériel spécial sont excentrés et réglables en largeur pour permettre de positionner rapidement les boulons des roues.

Geräte für die sichere Montage und Demontage von Reifen von PKW, Lieferwagen und SUV platziert auf 2 Säulen-Bühnen oder Doppel-Scheren-Hebebühnen.

Fußbedienung für Art. SIF/XR und pneumatischen Antrieb für Art. SIF/XR IP. Außermittige und- breitverstellbare Rollen aus besonderem Material, um den schnellen Einbau der Mütterschrauben zu ermöglichen.

ART. SIF/XR IP

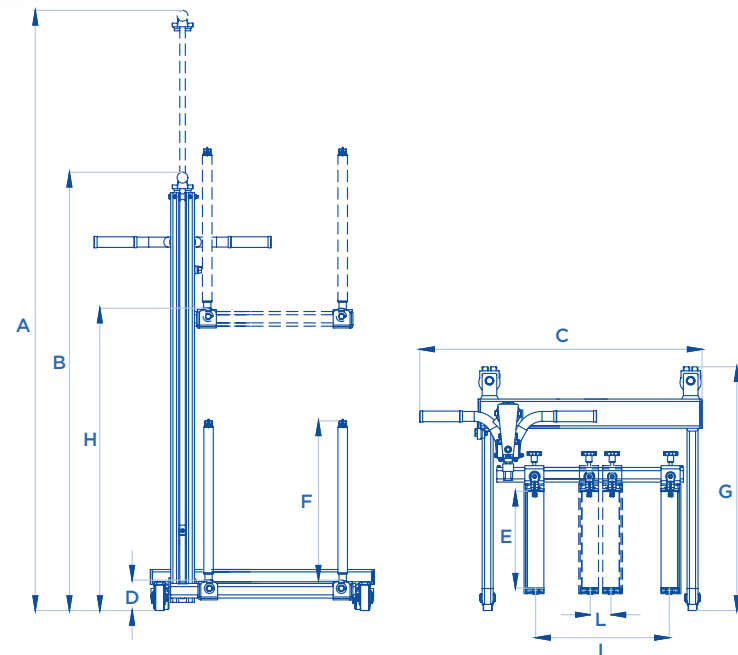

 ART.	 100 kg	 8 - 10 bar	 A mm	 B mm	 C mm	 D mm	 E mm	 F mm	 G mm	 H mm	 I mm	 L mm	 KG
SIF/XR IP	100 kg	8 - 10 bar	2100	1250	750	100	295	425	760	940	355	45	60

 Alimentazione pneumatica • Pneumatic feeding • Pression d'alimentation • Benötigter Luftdruck

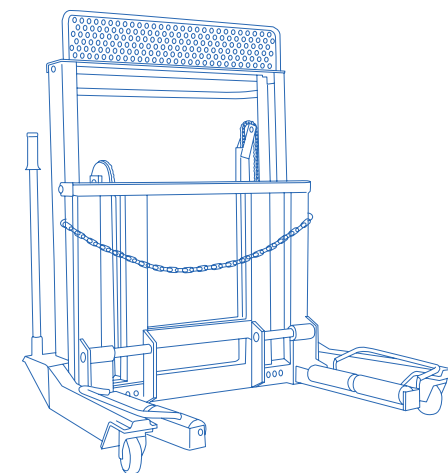

**ATTREZZATURE  
PER VEICOLI INDUSTRIALI**

HEAVY VEHICLES EQUIPMENT  
EQUIPEMENTS POUR POIDS LOURDS  
GERÄTE FÜR LKW-REPARATUREN

Made in Italy 



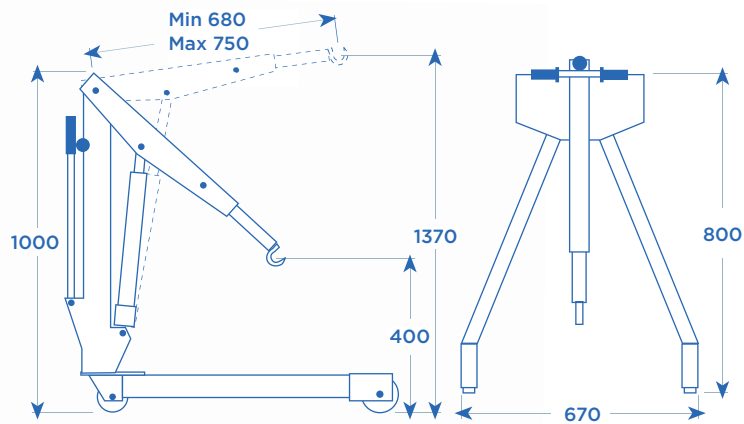

### ART. 141

Gru idraulica per stacco e riattacco balestre.

Corredata di attacco a due catene per un rapido aggancio delle balestre.

Hydraulic crane to detach and reattach leaf springs. It is fitted with hook and two chains to clasp the leaf spring quickly.

Grue hydraulique pour détacher et rattacher les ressorts de suspension. Elle est équipée de crochet à deux chaînes pour un accrochage rapide du ressort de suspension.

Hydraulikkran zum Aus- und Einbau von Blattfedern. Die Aufhängung ist mit 2 Ketten ausgestattet, wodurch ein rasches Aufhängen der Federn möglich ist. Bedienung mit Handpumpe.



ART. 141

ART.

141



250 kg



150 kg



### ART. 143

Sollevatore idraulico per smontaggio e montaggio dei motori. Dotato di appoggi meccanici di sicurezza, valvola di protezione contro i sovraccarichi e due ruote girevoli per la massima manovrabilità.

Hydraulic trolley to mount and dismount engines. Equipped with mechanical safety supports, safety valve in case of overloads and two turning wheels to guarantee the best manoeuvrability.

Elévateur hydraulique à monter et démonter les moteurs. Appuis mécaniques de sécurité, soupape de sécurité anti-surcharge et deux roues pivotantes pour faciliter les déplacements.

Wagenheber für den Aus- und Einbau von LKW-Motoren. Mit mechanischer Sicherheitsabstützungen, Überlastventil gegen jeder Überlastung und mit zwei lenkbaren Rädern, um die maximale Wendigkeit zu sichern.



143



1500 Kg



1700



500



250



700

ART. 143



ART.					
		mm	mm	mm	mm
<b>243</b>	1000 Kg	1080	650	260	960
<b>243/A</b>	1500 kg	1080	650	260	960



## ART. 243/A

### TRACCIATO TECNICO COSTRUTTIVO

- Sollevatore idraulico per smontaggio e montaggio dei cambi e dei differenziali.
- Dotato di piattaforma orientabile e regolabile tramite braccio a vite.
- Robusta struttura in acciaio saldato.
- Comando di discesa "uomo presente".
- Dotato di valvola di protezione contro i sovraccarichi.
- Le quattro ruote girevoli garantiscono un posizionamento preciso.
- Ruote in poliuretano (Art. 243).
- Ruote in acciaio (Art. 243/A).

### TECHNICAL AND STRUCTURAL LAY-OUT

- Hydraulic jack to mount and dismount gearboxes and differential gears.
- Adjustable platform through a screw.
- Compact structure made of welded steel.
- "Man standing-by" descent control device.
- Safety valve to avoid any possible overload.
- Four turning wheels to guarantee a precise positioning.
- Wheels made of polyurethane (Art. 243).
- Wheels made of steel (Art. 243/A).

### RELEVÉ TECHNIQUE

- Elévateur hydraulique à monter et démonter les boîtes de vitesse et les différentiels.
- Plateforme orientable réglable par bras à vis.
- Structure compacte en acier soudé.
- Commande de descente de type "homme-mort".
- Soupape de sécurité anti-surcharge.
- Quatre roues pivotantes pour un positionnement très précis.
- Roues en polyuréthane (Art. 243).
- Roues en acier (Art. 243/A).

### TECHNISCHE UND KONSTRUKTIVE ANGABEN

- Hydraulisch Rangierheber für die Aus- und Einbau von LKW-Differenzialgetrieben.
- Mit einer schwenkbaren Plattform, die dank einer Schraubenwinde verstellbar ist.
- Kompakte Struktur aus geschweißtem Stahl.
- Totmann- Abstiegskontrolle.
- Überlastventil gegen jeder Überlastung.
- Mit vier lenkbaren Rädern, die eine genaue Lagerung sichern.
- Polyurethanrädern (Art. 243).
- Stahlrädern (Art. 243/A).

## ART. 388/B

Attrezzo universale per smontaggio, rimontaggio e movimentazione ruote dei veicoli pesanti. Particolarmente indicato per una centratura rapida e pratica dei bulloni in fase di montaggio. Indispensabile per camionisti in caso di foratura.

Universal tool for the disassembling, reassembling and moving of heavy vehicles' wheels. Particularly suited for a fast and practical centring of the bolts during the assemblage phase. Indispensable for lorry-drivers in case of puncture.

Outil universel à démonter, remonter et déplacer les roues de poids lourds. Particulièrement indiqué pour le centrage rapide et pratique des boulons en phase de montage. Indispensable aux camionneurs en cas de crevaison d'un pneu.

Gerät zur Montage und Demontage sowie den Transport von LKW-Reifen. Speziell geeignet für ein schnelles Zentrieren der Radbolzen bei der Montage. Unentbehrliches Gerät im Falle eines Reifenschadens.

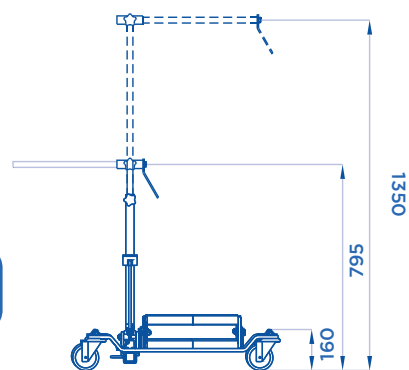
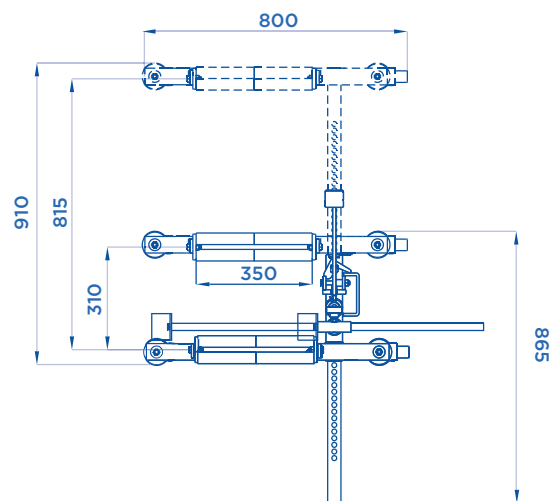

ART.

388/B



200 Kg



## ART. 227

Apparecchio a funzionamento idraulico per operare su pesanti automezzi per lo smontaggio e montaggio di ruote semplici e gemellari, con comando sia a mano che a pedale. Completo di 4 ruote girevoli e doppi rulli a cuscinetti sui bracci di sollevamento. Bracci regolabili in senso trasversale.

Hydraulic functioning apparatus which operates on heavy vehicles to disassemble simple and twin wheels. It has a hand and foot-lever control. It is equipped with 4 turning wheels and double rolls with bearings on hoisting arms. The arms are adjustable in transversal directions.

Elévateur hydraulique à monter et démonter les roues simples ou jumelées des poids lourds, avec commande manuelle et à pédale. Equipé de 4 roues pivotantes et de double rouleaux sur les bras de levage. Bras réglables dans le sens transversal.

Hydraulik-Gerät für die Arbeit an schweren Fahrzeugen. Geeignet zur Demontage und Montage einzelner Reifen sowie Zwillingsreifen. Sowohl Hand-als auch Pedalbedienung. Ausgestattet mit lenkbaren Rädern und Tragarmen mit doppelten, kugelgelagerten Rollen. Durch einfaches Verstellen der Tragarme läßt sich das Gerät den verschiedenen Reifendurchmessern schnellstens anpassen.

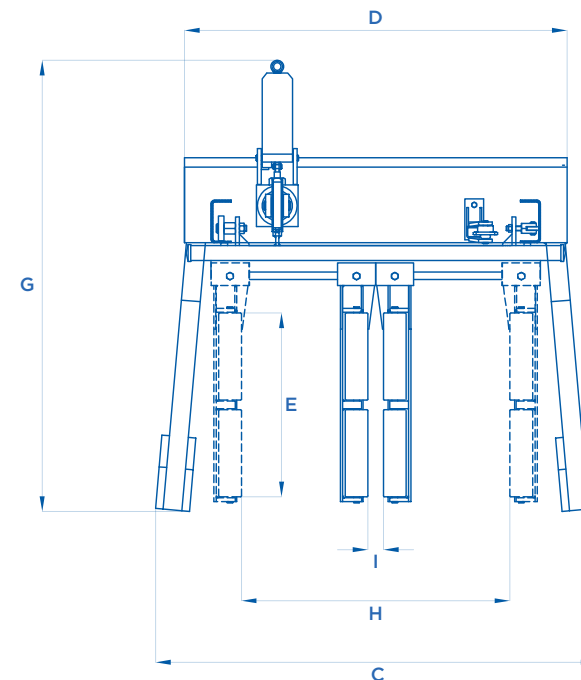
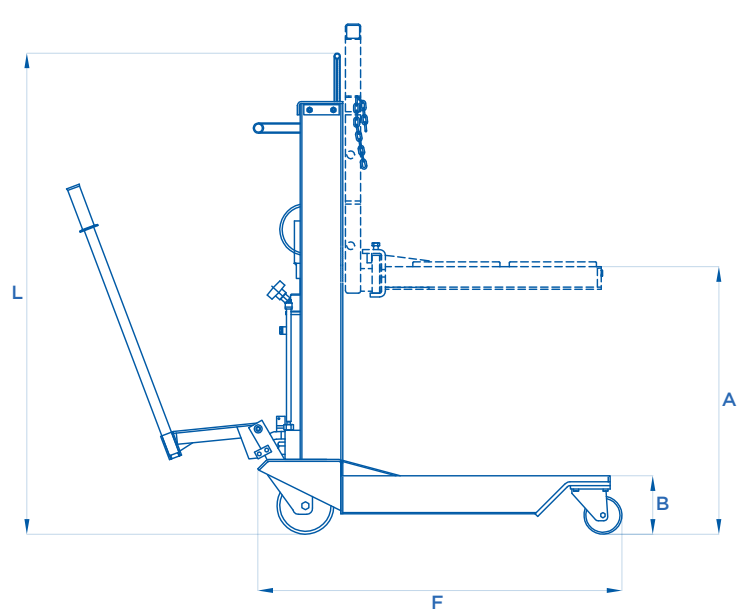

ART.		A	B	C	D	E	F	G	H	I	L
		mm	mm	mm	mm	mm	mm	mm	mm	mm	mm
227	700 kg	650	160	1150	1000	490	920	1150	770	10	1410



ART. 227/A

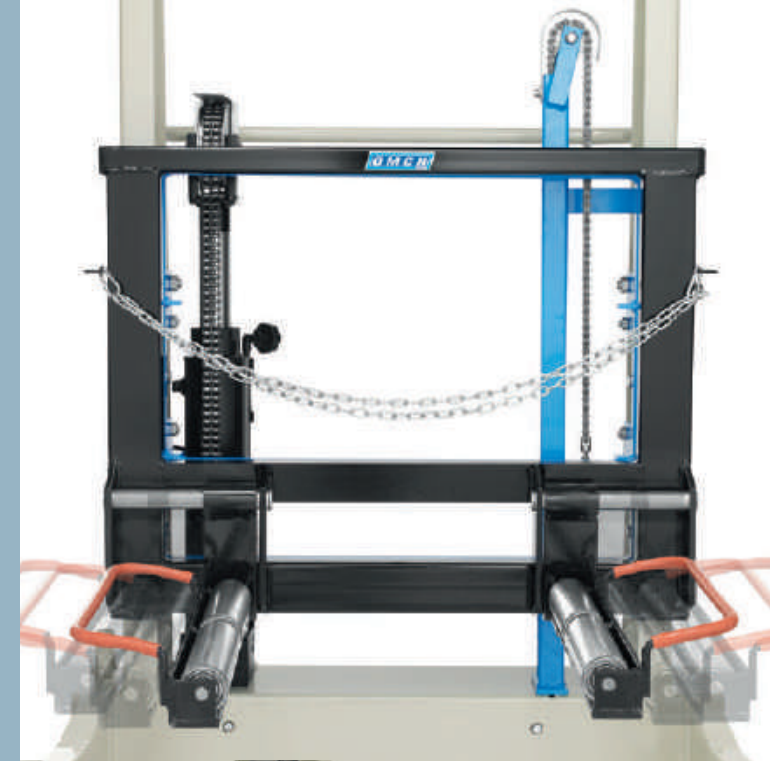

## ART. 227/A

Apparecchio a funzionamento idraulico per operare su pesanti automezzi per lo smontaggio e montaggio di ruote semplici e gemellari, con comando sia a mano che a pedale. Completo di 4 ruote girevoli e doppi rulli a cuscinetti sui bracci di sollevamento. **Bracci regolabili in senso trasversale e reclinabili onde facilitare l'operazione di centratura dei fori.**

Hydraulic functioning apparatus which operates on heavy vehicles to disassemble simple and twin wheels. It has a hand and foot-lever control. It is equipped with 4 turning wheels and double rolls with bearings on hoisting arms. **The arms are adjustable in transversal directions and reclining, in order to make the hole centering easier.**

Elévateur hydraulique à monter et démonter les roues simples ou jumelées des poids lourds, avec commande manuelle et à pédale. Equipé de 4 roues pivotantes et de double rouleaux sur les bras de levage.

**Bras réglables dans le sens transversal et inclinables, afin de faciliter le centrage des trous des jantes.**

Hydraulik-Gerät für die Arbeit an schweren Fahrzeugen. Geeignet zur Demontage und Montage einzelner Reifen sowie Zwillingsreifen. Sowohl Hand-als auch Pedalbedienung. Ausgestattet mit lenkbaren Rädern und Tragarmen mit doppelten, kugelgelagerten Rollen.

**Zusätzliches Neigen des Lifts möglich, um das genaue Zentrieren des Rades zu erleichtern.**

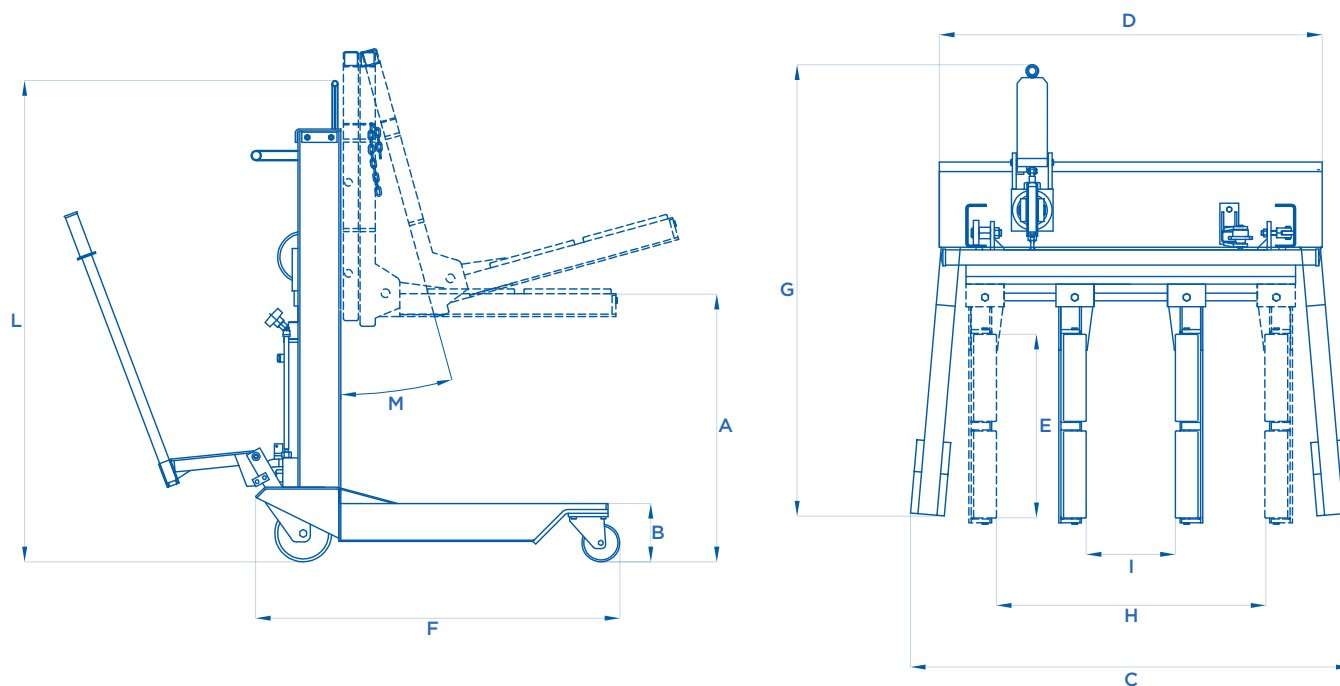

ART.		A mm	B mm	C mm	D mm	E mm	F mm	G mm	H mm	I mm	L mm	M $\alpha$
227/A	700 kg	650	160	1150	1000	490	920	1150	740	470	1410	10°





ART. 227/B



ART. 227/BI

### ART. 227/B

Apparechio a funzionamento idraulico per operare su pesanti automezzi per lo smontaggio e montaggio di ruote semplici e gemellari, con comando sia a mano che a pedale. Completo di 4 ruote girevoli e doppi rulli a cuscinetti sui bracci di sollevamento. Bracci regolabili in senso trasversale e reclinabili onde facilitare l'operazione di centratura dei fori. **Grazie ad una maggiore altezza di sollevamento ed alla sua conformazione, è anche adatto per montare le ruote sulle macchine tornitrici.**

Hydraulic functioning apparatus which operates on heavy vehicles to disassemble simple and twin wheels. It has a hand and foot-lever control. It is equipped with 4 turning wheels and double rolls with bearings on hoisting arms. The arms are adjustable in transversal directions and reclining, in order to make the hole centering easier. **Thanks to a greater lifting height and to its shape it is also suitable to mount wheels on turning machines.**

Elévateur hydraulique à monter et démonter les roues simples ou jumelées des poids lourds, avec commande manuelle et à pédale. Equipé de 4 roues pivotantes et de double rouleaux sur les bras de levage. Bras réglables dans le sens transversal et inclinables, afin de faciliter le centrage des trous des jantes. **Compte tenu de sa plus grande hauteur de levage et de sa forme, il peut aussi être utilisé pour le montage des roues sur les tours automatiques.**

Hydraulik-Gerät für die Arbeit an schweren Fahrzeugen. Geeignet zur Demontage und Montage einzelner Reifen sowie Zwillingsreifen. Sowohl Hand-als auch Pedalbedienung. Ausgestattet mit lenkbaren Räder und Tragarmen mit doppelten, kugelgelagerten Rollen. **Zusätzliches Neigen des Lifts möglich, um das genaue Zentrieren des Rades zu erleichtern. Aufgrund seiner größeren Hubhöhe und Ausführung ist es möglich, mit diesem Gerät auch Werkstatt-Service-maschinen zu bestücken.**

### ART. 227/BI



Azionamento idropneumatico a pulsantiera.

Hydropneumatic functioning with push-buttons.

A fonctionnement hydropneumatique et boîtier de commande à boutons poussoirs.

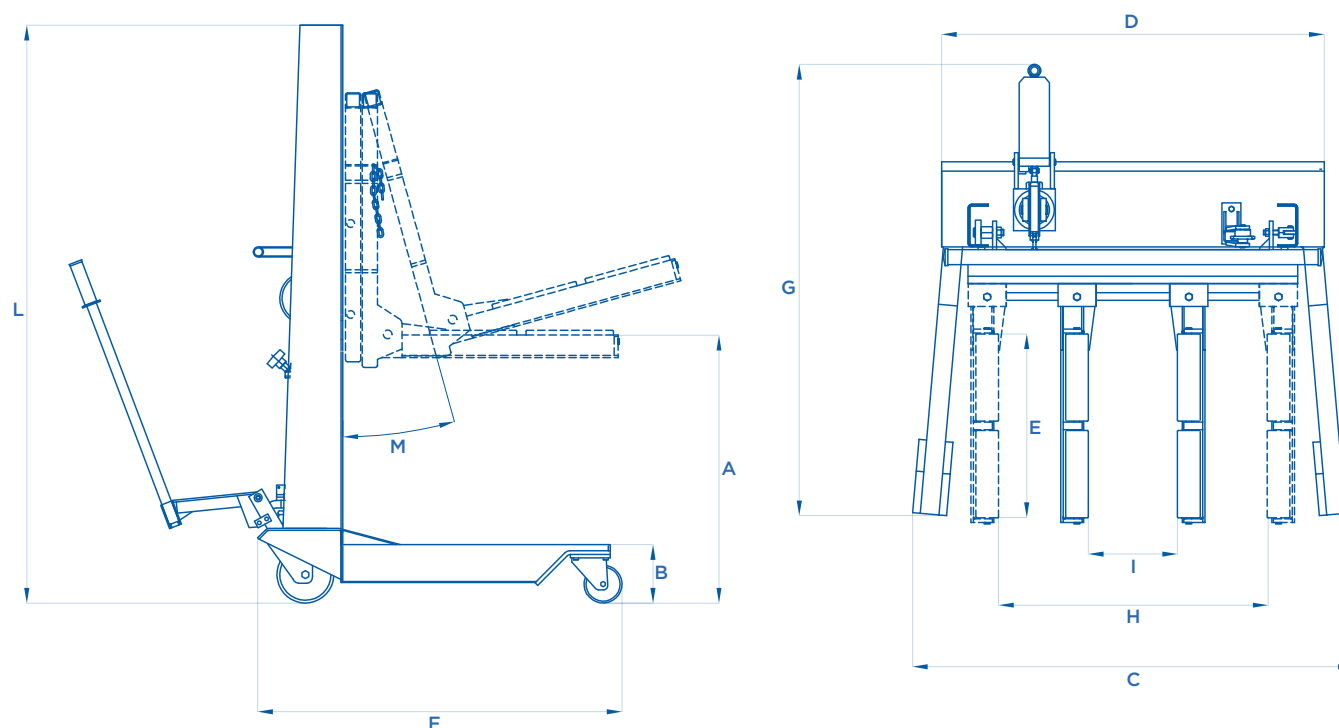
Mit hydropneumatischen Funktionen und Drucktasten.



ART.		A 	B 	C 	D 	E 	F 	G 	H 	I 	L 	M 
227/B	700 kg	920	160	1170	1010	490	930	1180	670	410	1445	10°
227/BI	700 kg	920	160	1170	1010	490	930	1180	670	410	1445	10°



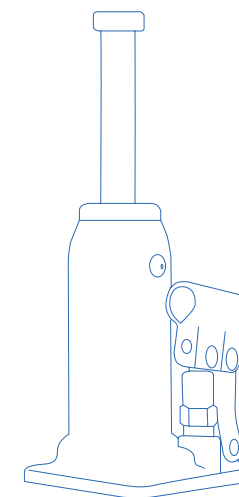

**SOLLEVATORI IDRAULICI A BOTTIGLIA  
E BINDE IDRAULICHE**

HYDRAULIC BOTTLE JACKS AND HYDRAULIC TRACK JACKS  
CRICS A BOUTEILLE ET CRICS LEVE-MACHINE HYDRAULIQUES  
HYDRAULISCHE WAGENHEBER UND MASCHINENHEBER

Made in Italy 

# SOLLEVATORI IDRAULICI A BOTTIGLIA

HYDRAULIC BOTTLE JACKS  
CRICS A BOUTEILLE HYDRAULIQUES  
HYDRAULISCHE WAGENHEBER



ART. 125



ART. 126



ART. 126/A



ART. 127



ART. 129



ART. 128



#### TRACCIATO TECNICO COSTRUTTIVO

- Dodici modelli con portate da 3 a 50 ton.
- Struttura sovradimensionata in acciaio ad alta resistenza; la più solida sul mercato.
- Base d'appoggio di grandi dimensioni a garanzia della massima stabilità.
- Valvola di protezione contro i sovraccarichi incorporata.
- I modelli più pesanti sono dotati di maniglia per agevolare il trasporto.
- Avvicinamento al punto di sollevamento rapido e preciso grazie alla vite incorporata (escluso art. 125 - 125/A - 130/A).

#### TECHNICAL AND STRUCTURAL LAY-OUT

- Twelve models with different capacities from 3 to 50 tons.
- Oversized structure made of very resistant steel: the most solid on the market.
- Big base for the best stability.
- Safety valve to avoid any possible overload.
- The heaviest models are equipped with a handle to ease transport.
- Quick and precise approach under the lifting points by screw (except art. 125 - 125/A - 130/A).

#### RELEVÉ TECHNIQUE

- Douze modèles avec des capacités différentes de 3 à 50 tons.
- Structure surdimensionnée en acier très résistante, la plus solide sur le marché.
- Base d'appui très large une stabilité maximale.
- Soupape de sécurité anti-surchage.
- Les modèles les plus lourds sont munis d'une poignée pour faciliter le transport.
- Approche ultra rapide et précise sous le point de levage grâce à la vis incorporée (sauf art. 125 - 125/A - 130/A).

#### TECHNISCHE UND KONSTRUKTIVE ANGABEN









- Zwölf Modelle mit verschiedenen Tragfähigkeiten (vom 3 bis 50 Tonnen).
- Überdimensionierte Struktur aus hochfestem Stahl, die die tragfähigste auf dem Markt ist.
- Sehr große Stellfläche, um die maximale Stabilität zu sichern.
- Angebautes Überlastventil gegen jeder Überlastung.
- Die schwerste Modelle sind mit einem Griff, um den Transport zu erleichtern, ausgestattet.
- Schnelle und präzise Annäherung zu dem Hebepunkt dank die angebaute Schraube (ausgenommen art. 125 - 125/A - 130/A).



ART. 130



ART. 130/A

ART.		 A mm	 B mm	 C mm	 D mm	 E mm	 F mm	 KG
<b>125</b>	3000 kg	325	200	125		120x120	40	4,8
<b>125/A</b>	3000 kg	400	240	160		120x120	40	5,2
<b>126</b>	5000 kg	485	220	140	125	120x120	40	5,5
<b>126/A</b>	5000 kg	370	190	105	75	120x120	40	5
<b>126/B</b>	5000 kg	630	275	195	160	120x120	40	6,5
<b>127</b>	10000 kg	515	240	150	125	140x140	50	8
<b>127/A</b>	10000 kg	710	310	225	175	140x140	50	9,8
<b>128</b>	15000 kg	515	245	150	120	140x140	60	10
<b>129</b>	20000 kg	575	285	165	125	170x170	60	18
<b>129/A</b>	25000 kg	575	285	165	125	170x170	60	19
<b>130</b>	30000 kg	585	295	165	125	225x183	65	25
<b>130/A</b>	50000 kg	430	270	160		280x230	90	53

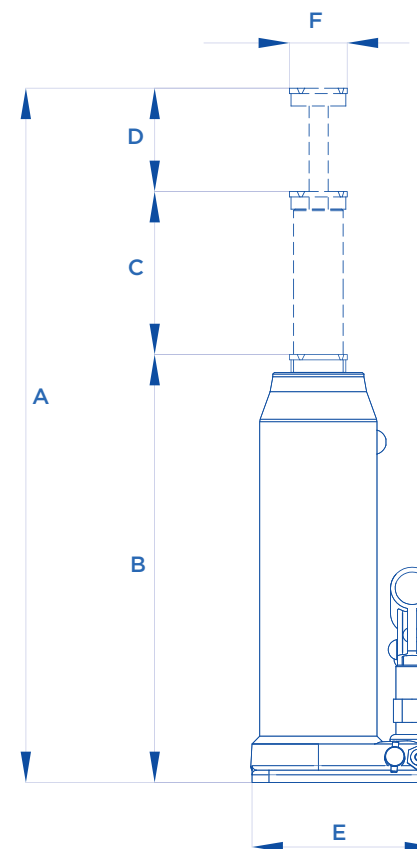



# BINDE IDRAULICHE

HYDRAULIC TRACK JACKS  
CRICS LEVE-MACHINE HYDRAULIQUES  
MASCHINENHEBER



ART. 130/B

ART.		MAX mm	MIN mm
130/B	5000 kg	170	30

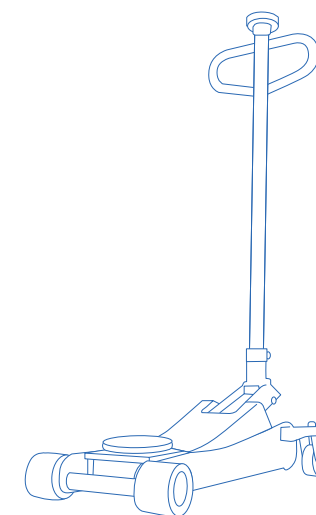

**SOLLEVATORI IDRAULICI  
A CARRELLO**

HYDRAULIC TROLLEY JACKS  
CRICS ROULEURS HYDRAULIQUES  
HYDRAULISCHE RANGIERHEBER

Made in Italy 



ART. 3010



ART. 3000



### TRACCIATO TECNICO COSTRUTTIVO

- Design completamente innovativo.
- Punti presa super ribassati.
- Manico ergonomico.
- Supporto piattello a base ampia.
- Piattello in gomma.
- Ruote in nylon (Art. 3000).
- Dotato di ruote in poliuretano con doppi rulli basculanti anteriori (Art. 3010).
- Dotato di comando di discesa a pedale (Art. 3010).
- Dotato di comando di discesa manuale (Art. 3000).

### TECHNICAL AND STRUCTURAL LAY-OUT

- Completely innovative design.
- Very low profile.
- Ergonomic handle.
- Support holder with wide base.
- Rubber covered support.
- Nylon wheels (Art. 3000).
- Equipped with double frontal balancing rolls and rear turning wheels in polyurethane (Art. 3010).
- Foot descent-control (Art. 3010).
- Hand descent-control (Art. 3000).



### RELEVÉ TECHNIQUE

- Innovation du design.
- Points de prise surbaissés
- Manche ergonomique.
- Support plateau à base large.
- Plateau caoutchouc.
- Roues en nylon (Art. 3000).
- Avec roues avant en polyuréthane à double rouleaux à bascule (Art. 3010).
- Avec commande de descente à pied (Art. 3010).
- Avec commande de descente manuelle (Art. 3000).

### TECHNISCHE UND KONSTRUKTIVE ANGABEN

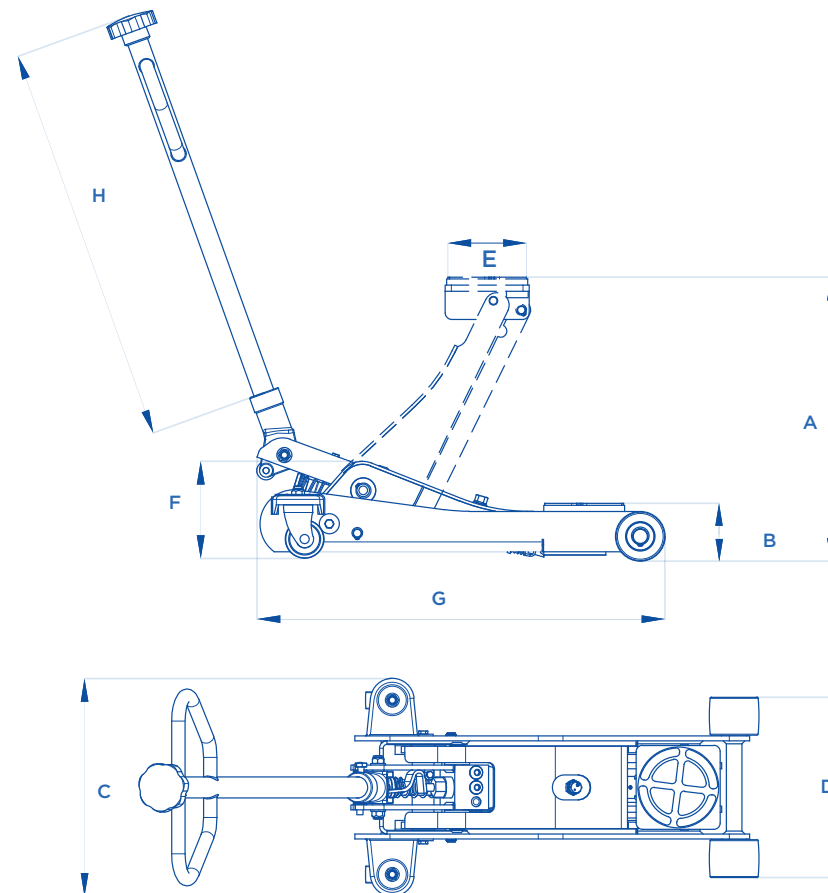
- Völlig innovatives Design.
- Super abgeflachte Aufnahmepunkte.
- Ergonomische Zugstang.
- Tellerstütz mit weiter Grundlage.
- Gummiteller.
- Nylonräder (Art. 3000).
- Mit polyurethan Rädern, von denen kippen doppelten Vorderrollen (Art. 3010).
- Mit Fußhebel Abstiegkontrolle (Art. 3010).
- Mit manueller Abstiegkontrolle (Art. 3000).



ART.		A mm	B mm	C mm	D mm	E mm	F mm	G mm	H mm	
<b>3000</b>	2000 kg	480	95	350	290	130	200	660	810	39
<b>3010</b>	2000 Kg	710	95	480	485	130	210	1000	780	67



ART. 3020

ART. 3030



### TRACCIATO TECNICO COSTRUTTIVO

- Design completamente innovativo.
- Punti presa super ribassati.
- Manico ergonomico.
- Supporto piattello a base ampia.
- Dotati di pedale di avvicinamento.
- Dotati di comando di discesa manuale.
- Piattello in gomma (Art. 3020).
- Piattello in acciaio (Art. 3030).
- Ruote in nylon.

### TECHNICAL AND STRUCTURAL LAY-OUT

- Completely innovative design.
- Very low profile.
- Ergonomic handle.
- Support holder with wide base.
- Equipped with foot-approaching control.
- Hand descent-control.
- Rubber covered support (Art. 3020).
- Stainless steel support (Art. 3030).
- Nylon wheels.

### RELEVÉ TECHNIQUE

- Innovation du design.
- Points de prise surbaissés.
- Manche ergonomique.
- Support plateau à base large.
- Avec pédale d'approche.
- Avec commande de descente manuelle.
- Plateau caoutchouc (Art. 3020).
- Plateau acier (Art. 3030).
- Roues en nylon.

### TECHNISCHE UND KONSTRUKTIVE ANGABEN

- Völlig innovatives Design.
- Super abgeflachte Aufnahmepunkte.
- Ergonomische Zugstang.
- Tellerstütz mit weiter Grundlage.
- Anbewegung Fußhebel.
- Mit manueller Abstiegskontrolle.
- Gummiteller (Art. 3020).
- Stahlteller (Art. 3030).
- Nylonräder.

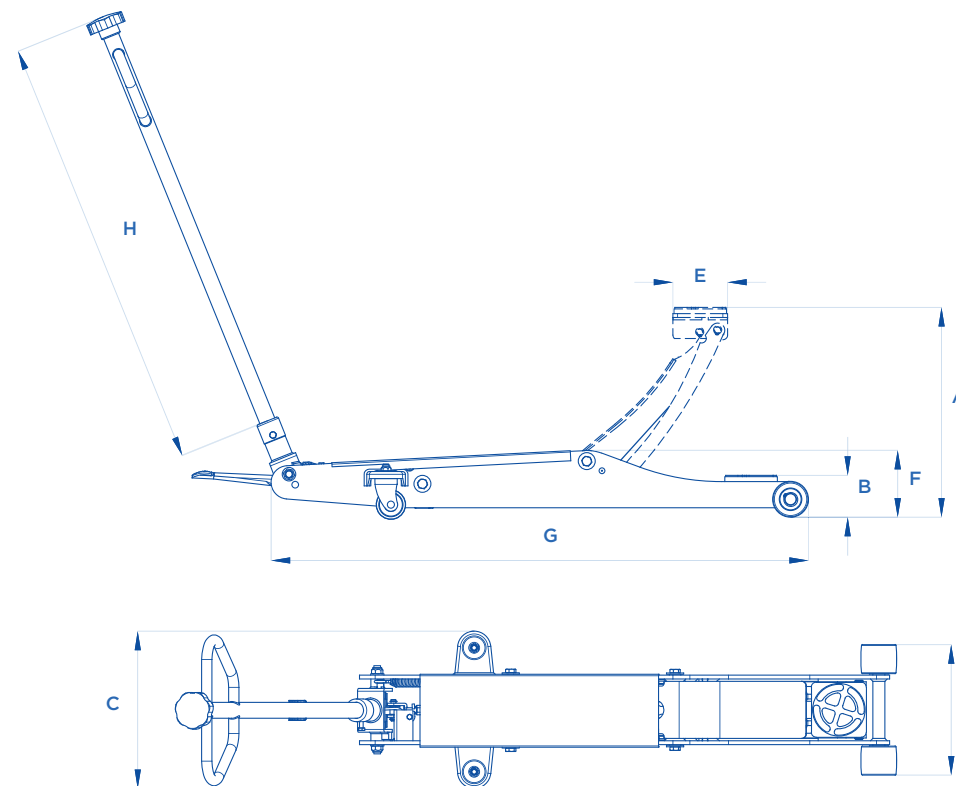

ART.		A  mm	B  mm	C  mm	D  mm	E  mm	F  mm	G  mm	H  mm	 KG
<b>3020</b>	3000 kg	505	90	290	275	130	145	1260	915	52
<b>3030</b>	6000 Kg	555	130	370	290	130	185	1600	915	80

**TOP  
LINE**



ART. 3100IP

## TRACCIATO TECNICO COSTRUTTIVO

- Sollevatore oleopneumatico a carrello.
- Indicato per il sollevamento di autovetture, SUV, veicoli commerciali e industriali.
- Design completamente innovativo.
- Punto presa super ribassato.
- Manico ergonomico.
- Supporto piattello a base ampia.
- Piattello in acciaio.
- Ruote in nylon.

## TECHNICAL AND STRUCTURAL LAY-OUT

- Air-hydraulic trolley jack.
- Suggested to lift cars, SUV, commercial vehicles and medium lorries.
- Completely innovative design.
- Very low profile.
- Ergonomic handle.
- Support holder with wide base.
- Stainless steel support.
- Nylon wheels.

## RELEVÉ TECHNIQUE

- Cric rouleur oléopneumatique.
- Conseillé pour le levage de voitures, tout-terrains et poids moyens.
- Innovation du design.
- Point de prise surbaissé.
- Manche ergonomique.
- Support plateau à base large.
- Plateau acier.
- Roues en nylon.

## TECHNISCHE UND KONSTRUKTIVE ANGABEN

- Hydropneumatischer Rangierheber.
- Bezeichnet für SUV, Fahrzeuge, Nutzfahrzeuge und medium LKW.
- Völlig innovatives Design.
- Super abgeflachte Aufnahmepunkte.
- Ergonomische Zugstang.
- Tellerstütz mit weiter Grundlage.
- Stahlsteller.
- Nylonräder.

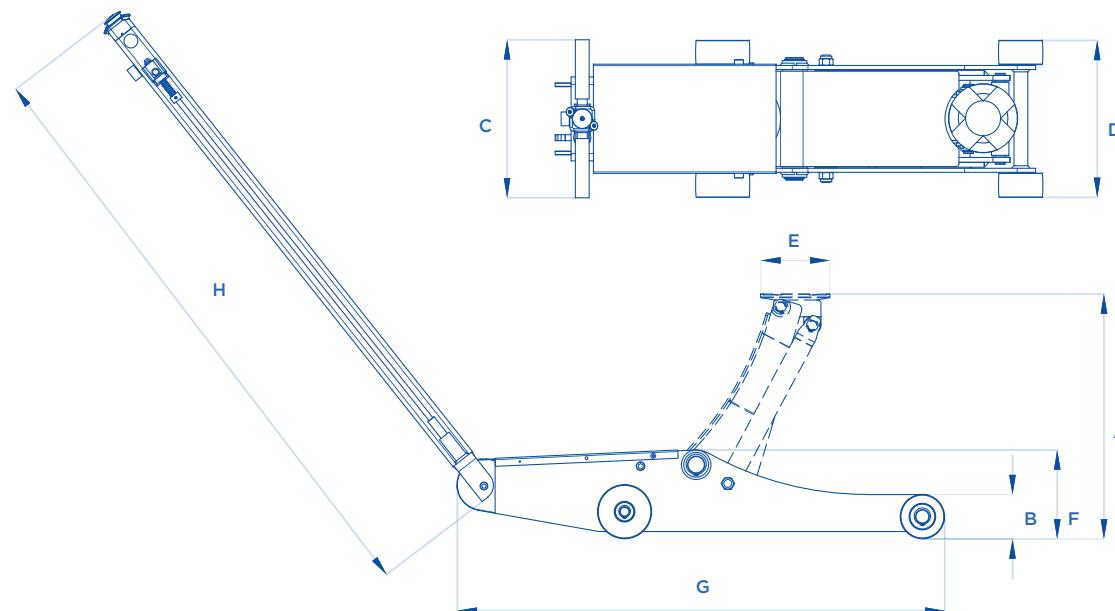

ART.			A mm	B mm	C mm	D mm	E mm	F mm	G mm	H mm	KG
3100IP	5000 kg	10 bar	500	90	320	320	140	180	970	1230	100

 Alimentazione pneumatica • Pneumatic feeding • Pression d'alimentation • Benötigter Luftdruck





**ART. 112/B**



**ART. 112**

**SERIE CORTA**  
SHORT SERIES  
SERIE COURTE  
KURZE AUSFÜHRUNG

**CLASSIC  
LINE**

**OPTIONAL**

**TAMPONE IN GOMMA**

Rubber-covered support  
Plateau caoutchouc  
Gummiteller

**ART. 392/A**



✓ ART. 112 • 112/A

**ART. 392/B**

✓ ART. 112/B • 112/C • 112/D

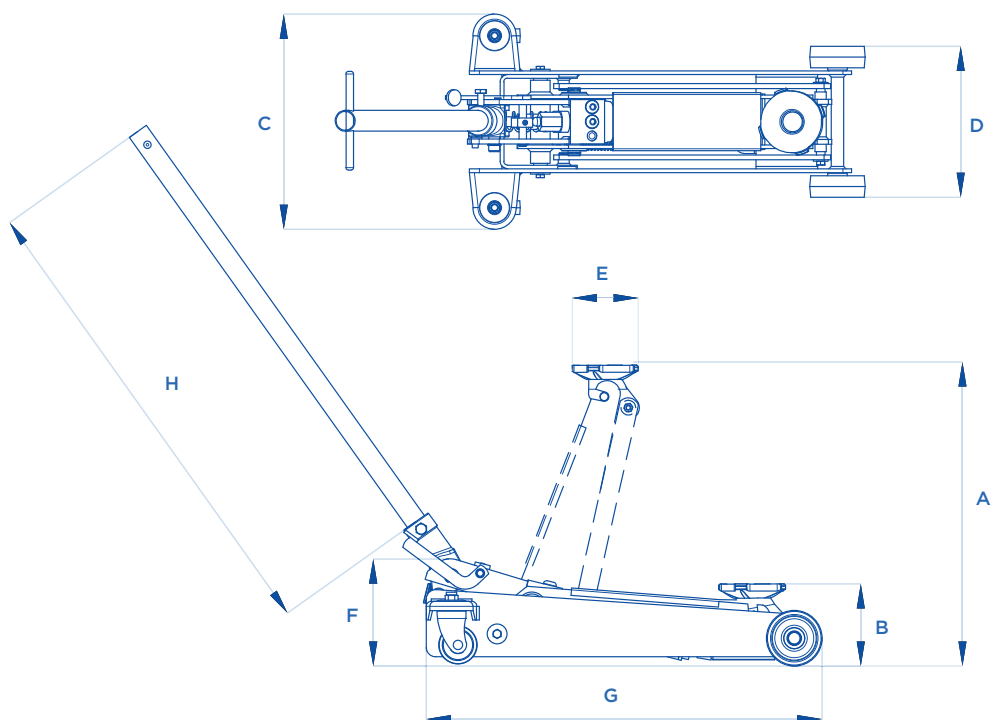



ART.		 A mm	 B mm	 C mm	 D mm	 E mm	 F mm	 G mm	 H mm	 KG
<b>112</b>	1200 kg	525	130	345	250	100	200	650	780	35
<b>112/A</b>	1500 kg	525	135	345	290	100	200	650	780	36
<b>112/B</b>	2500 kg	610	145	375	310	130	210	760	780	51
<b>112/C</b>	1200 kg	750	145	370	300	130	210	950	780	59
<b>112/D</b>	1500 kg	800	145	370	300	130	210	950	780	60

 Comando di discesa a pedale • Foot descent-control • Commande de descente à pédale • Fußpumpe Kontrolle



ART. 114

**SERIE MEDIA**  
MIDDLE CAPACITY SERIES  
SERIE MOYENNE PORTEE  
MITTLERE AUSFÜHRUNG

**CLASSIC  
LINE**

**OPTIONAL**

**TAMPONE IN GOMMA**

Rubber-covered support  
Plateau caoutchouc  
Gummiteller

**ART. 392/C**

✓ ART. 113 • 114 • 115 • 116



ART. 118

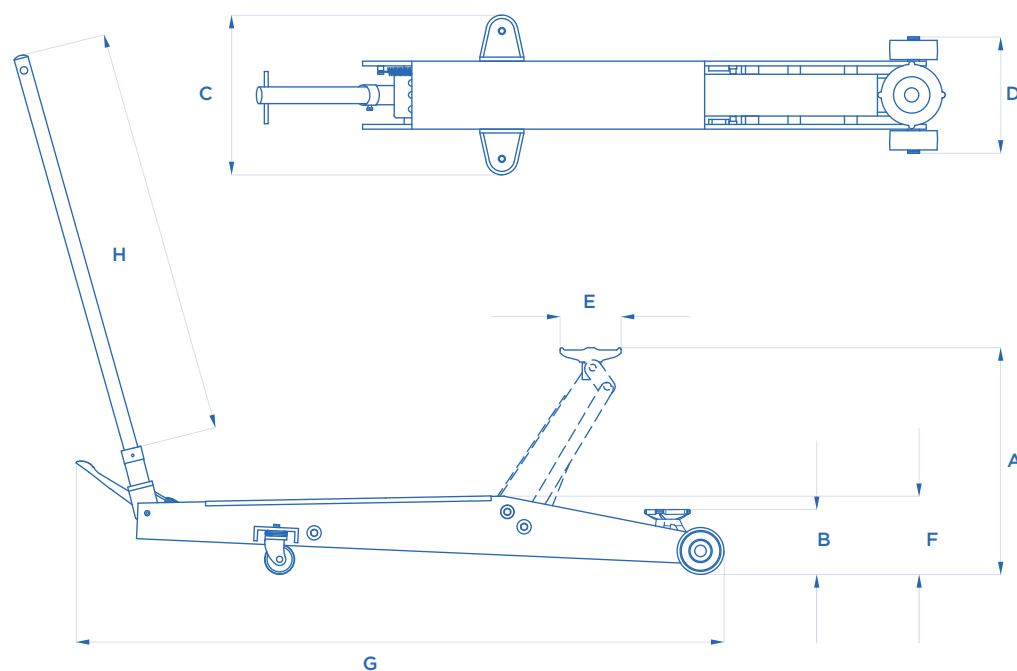

ART.		A  mm	B  mm	C  mm	D  mm	E  mm	F  mm	G  mm	H  mm	 KG
<b>113</b>	1500 kg	520	130	315	260	130	175	1190	920	45
<b>114</b>	2000 kg	520	130	325	270	130	175	1260	920	52
<b>115</b>	2500 kg	520	140	325	270	130	185	1280	920	54
<b>116</b>	3000 kg	520	140	325	270	130	185	1280	920	56
<b>117</b>	4000 kg	540	145	360	290	130	185	1480	920	78
<b>118</b>	5000 kg	550	155	360	290	130	185	1530	920	80
<b>118/A</b>	7000 kg	550	160	385	305	130	195	1630	920	90

 Dotati di pedale di avvicinamento • Equipped with foot-approaching control • Avec pédale d'approche • Anbewegung Fußhebe  
Comando di discesa a pedale • Foot descent-control • Commande de descente à pédale • Fußpumpe Kontrolle



ART. 120/A

ART. 119/A

**SERIE GRANDE ALZATA**

GREAT LIFT SERIES  
SERIE GRANDE LEVEE  
LANGHUB AUSFÜHRUNG



**OPTIONAL**

**TAMPONE IN GOMMA**







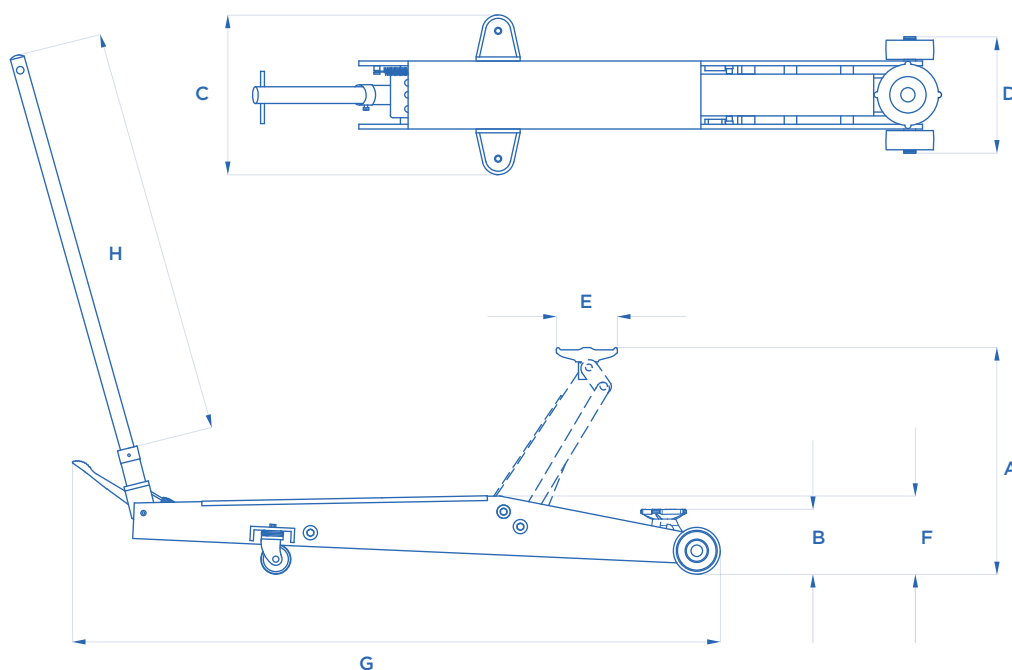

Rubber-covered support  
Plateau caoutchouc  
Gummiteller

**ART. 392/D**

✓ ART. 119 • 119/A • 120





ART.		A  mm	B  mm	C  mm	D  mm	E  mm	F  mm	G  mm	H  mm	 KG
<b>119</b>	1500 kg	850	130	340	440	130	195	1670	920	78
<b>119/A</b>	3000 kg	875	135	440	440	130	205	1750	920	91
<b>120</b>	3000 kg	1030	150	670	680	130	225	1790	900	140
<b>120/A</b>	5000 kg	1030	150	670	680	130	225	1790	900	170

 Dotati di pedale di avvicinamento • Equipped with foot-approaching control • Avec pédale d'approche • Anbewegung Fußhebe  
 Comando di discesa a pedale • Foot descent-control • Commande de descente à pédale • Fußpumpe Kontrolle

**SERIE GRANDE PORTATA**  
GREAT CAPACITY SERIES  
SERIE GRANDE PORTEE  
GROBE TRAGKRAFT AUSFÜHRUNG

**CLASSIC  
LINE**



ART. 122

ART. 123/A

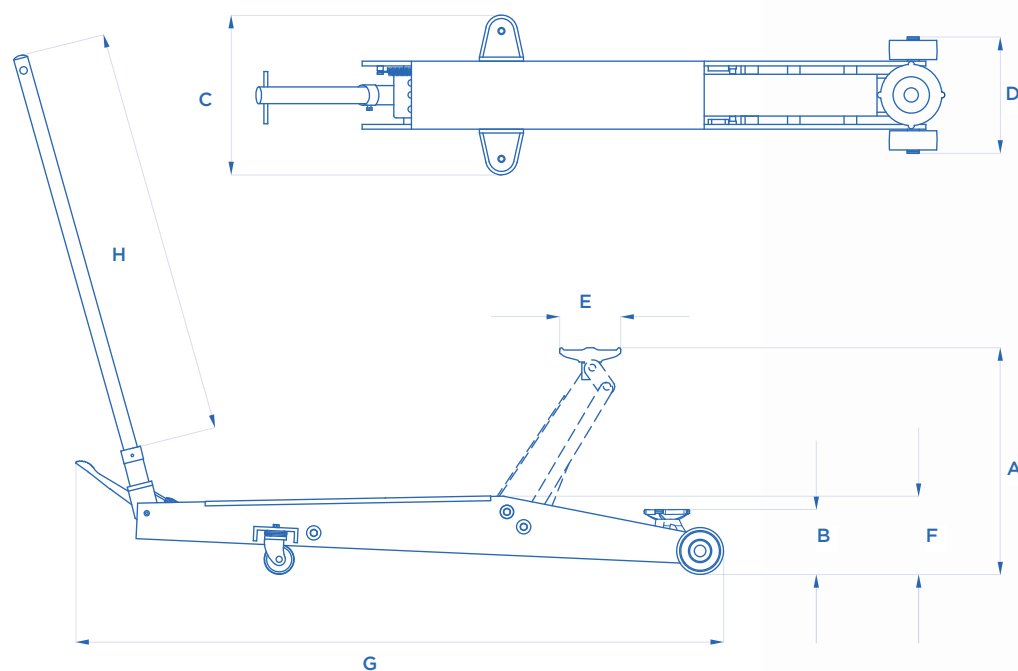

ART.		 A mm	 B mm	 C mm	 D mm	 E mm	 F mm	 G mm	 H mm	 KG
<b>122</b>	10000 kg	630	185	445	360	155	265	1880	900	150
<b>122/A</b>	12000 kg	635	190	445	390	155	270	1890	900	154
<b>123</b>	15000 kg	655	210	450	395	155	280	2030	900	176
<b>123/A</b>	20000 kg	655	210	450	395	155	280	2030	900	203
<b>124</b>	15000 kg	655	210	450	395	155	275	2740	900	200

 Dotati di pedale di avvicinamento • Equipped with foot-approaching control • Avec pédale d'approche • Anbewegung Fußhebe  
Comando di discesa a pedale • Foot descent-control • Commande de descente à pédale • Fußpumpe Kontrolle





**ART. K/012**



**ART. 253**



**ART. 254**

**SERIE CORTA**

SHORT SERIES

SERIE COURTE

KURZE AUSFÜHRUNG

**CLASSIC  
LINE**

**RUOTE IN NYLON**

Nylon wheels

Roues en nylon

Nylonräder



**OPTIONAL**

**TAMPONE IN GOMMA**

Rubber-covered support

Plateau caoutchouc

Gummiteller

**ART. 392/A**

✓ ART. 252 • 253

**ART. 392/B**

✓ ART. 254 • 255 • 256



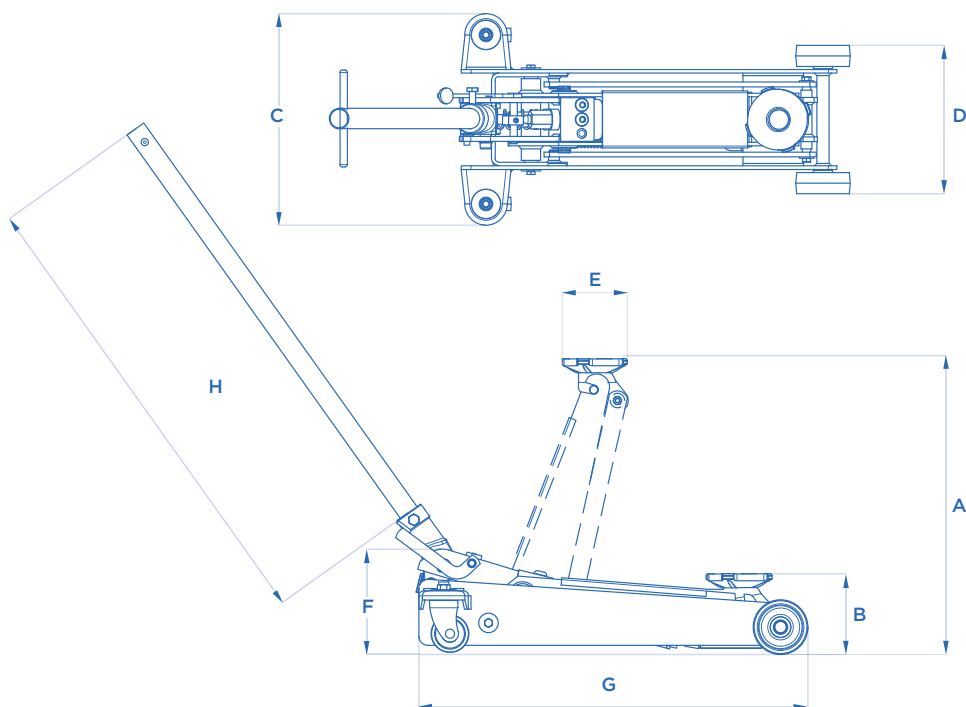

ART.		A mm	B mm	C mm	D mm	E mm	F mm	G mm	H mm	KG
K/012	800 kg	415	95	290	85	170	120	585	500	14
<b>252</b>	1500 kg	525	130	365	290	100	200	700	820	37
<b>253</b>	2000 kg	525	130	390	290	100	200	700	820	38
<b>254</b>	3000 kg	610	140	395	310	130	225	760	820	54
<b>255</b>	1300 kg	800	140	390	300	130	220	980	820	61
<b>256</b>	1600 kg	800	140	390	300	130	220	980	820	62



**ART. 263**



**ART. 259**

**SERIE MEDIA  
E GRANDE ALZATA**

MIDDLE CAPACITY AND GREAT LIFT SERIES  
SÉRIE MOYENNE PORTEE ET GRANDE LEVEE  
MITTLERE UND LANGHUB AUSFÜHRUNG

**CLASSIC  
LINE**

**OPTIONAL**

**TAMPONE IN GOMMA**

Rubber-covered support  
Plateau caoutchouc  
Gummiteller

**ART. 392/C**









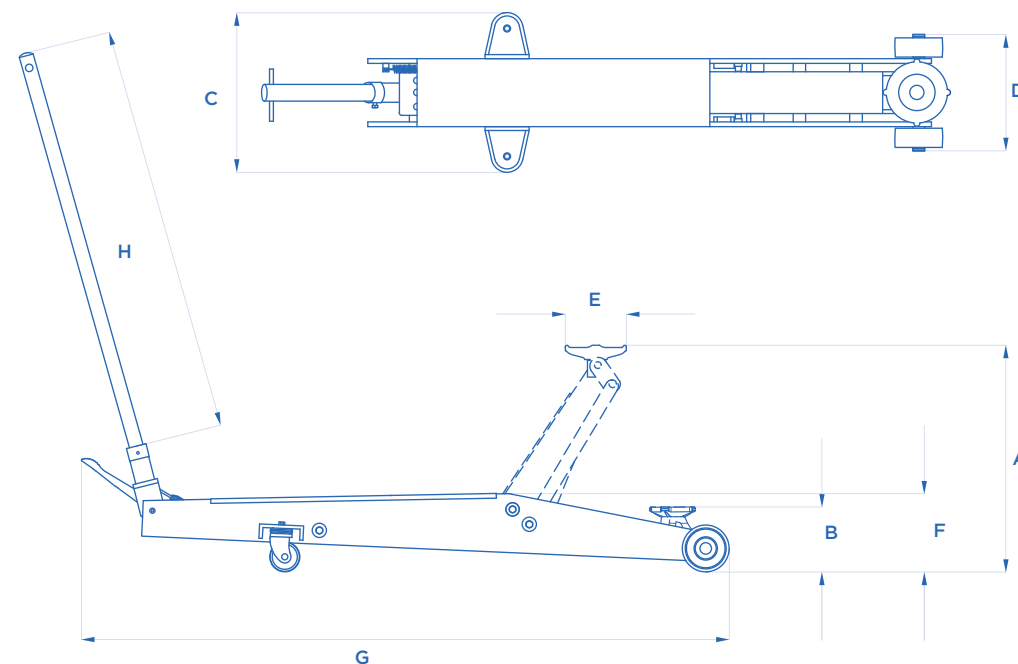

✓ ART. 257 • 259 • 260 • 261

**ART. 392/D**

✓ ART. 258





ART.		 A mm	 B mm	 C mm	 D mm	 E mm	 F mm	 G mm	 H mm	 KG
<b>257</b>	1500 kg	520	125	335	260	130	175	1190	920	47
<b>258</b>	1500 kg	900	125	340	270	130	195	1650	920	80
<b>259</b>	2000 kg	520	130	335	270	130	175	1250	920	54
<b>260</b>	2500 kg	520	140	335	270	130	185	1265	920	56
<b>261</b>	3000 kg	520	140	335	270	130	185	1265	920	59
<b>262</b>	4500 kg	540	145	370	290	130	190	1485	920	83
<b>263</b>	6000 kg	550	150	360	290	130	190	1580	920	86
<b>264</b>	8000 kg	560	150	385	305	130	230	1650	920	100

 Dotati di pedale di avvicinamento • Equipped with foot-approaching control • Avec pédale d'approche • Anbewegung Fußhebe  
Comando di discesa manuale • Hand descent-control • Commande de descente manuelle • Manuelle Kontrolle

**SERIE GRANDE PORTATA**  
GREAT CAPACITY SERIES  
SERIE GRANDE PORTEE  
GROÙE TRAGKRAFT AUSFÜHRUNG

**CLASSIC  
LINE**



**ART. 265**



**ART. 267**

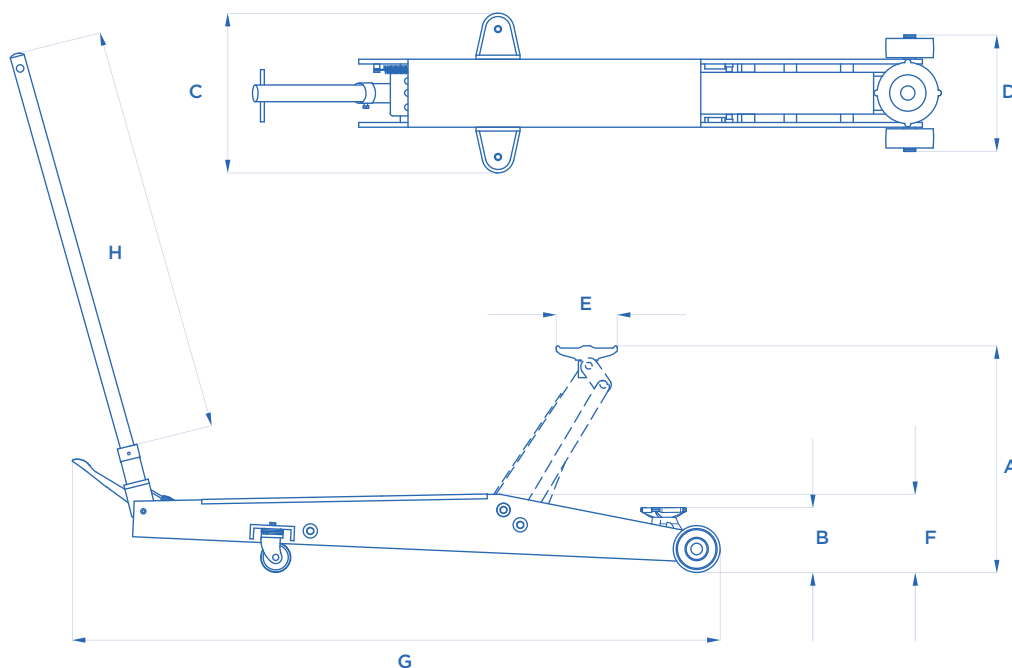

ART.		A  mm	B  mm	C  mm	D  mm	E  mm	F  mm	G  mm	H  mm	 KG
<b>265</b>	10000 kg	630	185	445	360	155	265	1880	900	148
<b>266</b>	15000 kg	655	210	450	395	155	280	2020	900	175
<b>267</b>	20000 kg	655	210	450	395	155	285	2020	900	200

 Dotati di pedale di avvicinamento • Equipped with foot-approaching control • Avec pédale d'approche • Anbewegung Fußhebe  
Comando di discesa manuale • Hand descent-control • Commande de descente manuelle • Manuelle Kontrolle



**ART. 1120/E**

**ART. 1120/F**

**SPECIAL  
LINE**

**OPTIONAL**

**TAMPONE IN GOMMA**

Rubber-covered support  
Plateau caoutchouc  
Gummiteller

**ART. 392/A**  
✓ ART. 1120/F

**ART. 392/B**  
✓ ART. 1120/E

**ART. 392/D**  
✓ ART. 1120/G



I Doppi rulli anteriori basculanti e le ruote posteriori girevoli in poliuretano, consentono di poter muovere i sollevatori anche sui grigliati e sono particolarmente indicati per interventi in fase di soccorsi stradali.

Thanks to the double frontal balancing rolls and to the rear turning wheels in polyurethane, these jacks can be moved also on floors with grates and they are suitable during breakdown services.

Grâce aux double rouleaux antérieurs basculants et aux roues pivotantes en polyuréthane on peut déplacer les crics sur des grilles et ils sont particulièrement indiqués pour les interventions pendant les secours routiers

Dank vorderer, kippbarer Doppelrollen und hinterer, drehbarer Räder aus Polyurethan, ist man in der Lage, die Rangierheber auch auf Gitterboden zu bewegen. Sie sind bestimmt geeignet während dem Schleppdienst.

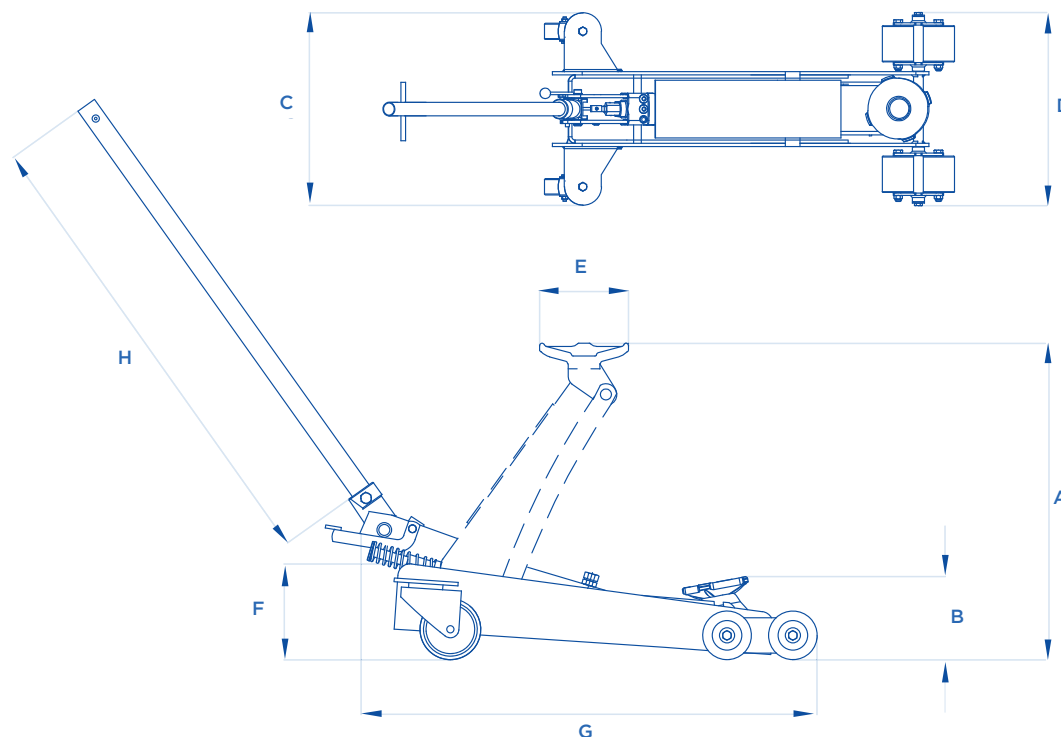

ART.		A mm	B mm	C mm	D mm	E mm	F mm	G mm	H mm	KG
<b>1120/E</b>	2000 kg	760	130	480	480	130	200	1080	910	65
<b>1120/F</b>	2000 kg	520	140	420	420	130	180	740	780	45
<b>1120/G</b>	1500 kg	850	130	570	540	130	200	1750	920	85

**i** Comando di discesa a pedale • Foot descent-control • Commande de descente à pédale • Fußpumpe Kontrolle





**SPECIAL  
LINE**

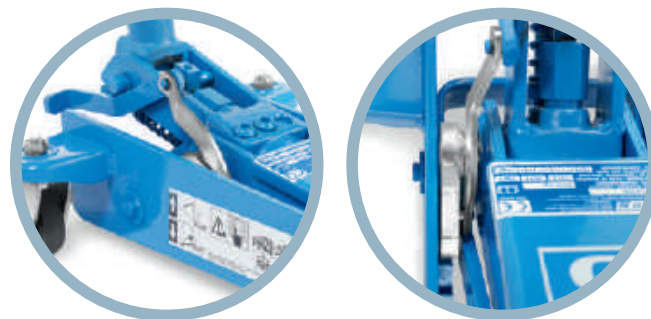
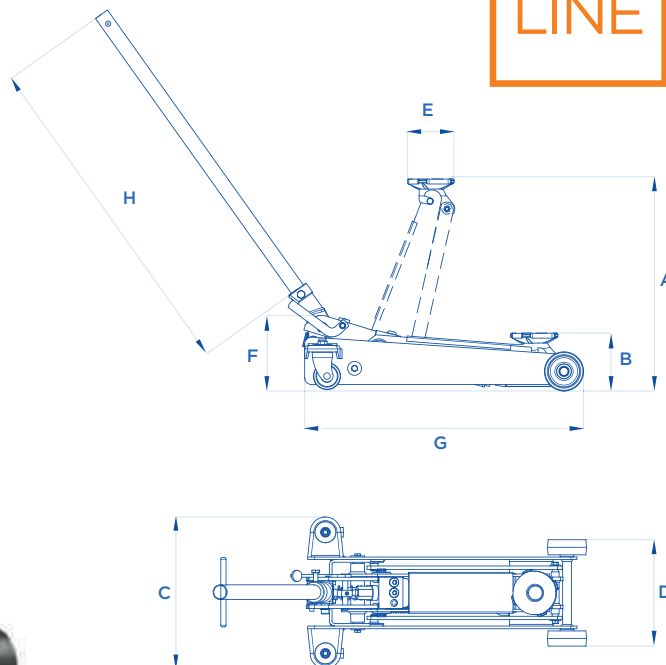

Completo di sicurezze meccaniche, ruote in nylon e supporto in acciaio ricoperto in gomma.

Complete with mechanical safeties, nylon wheels and rubber covered steel support.

Complet avec sûretés mécaniques, roues en nylon et support en acier recouvert en caoutchouc.

Mit mechanischen Sicherheitseinrichtungen, Nylonrädern und einer gummibeschichteten Stahlaufnahme.

ART.										
112/XR	2000 kg	525	120	350	290	130	215	650	780	35

**SPECIAL  
LINE**

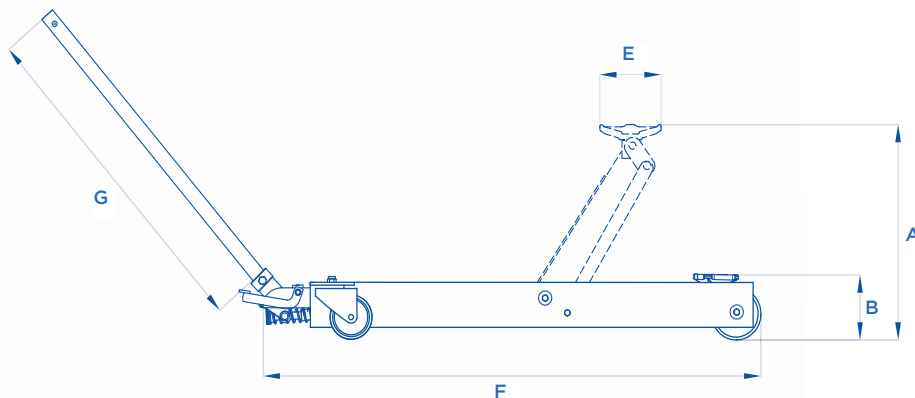
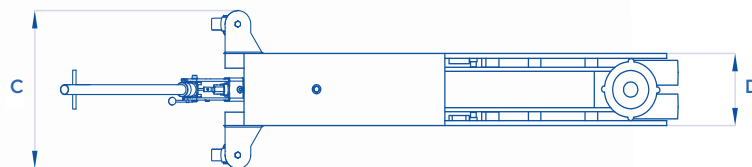

**OPTIONAL**

**ART. 392/A  
TAMPONE IN GOMMA**

Rubber-covered support  
Plateau caoutchouc  
Gummiteller



**ART.**



**A** mm

**B** mm

**C** mm

**D** mm

**E** mm

**F** mm

**G** mm

**KG**

**1130/XR**

1500 kg

510

100

360

205

100

1320

780

50

**NOTE**

---

---

---

---

---

---

---

---

---

---

---

---

---

---

---

---

---

---

---

---

---

---

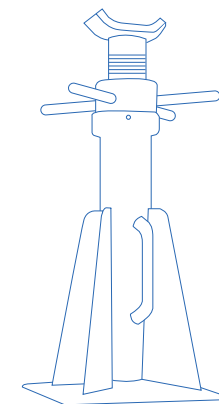

**COLONNETTE DI SOSTEGNO  
E CAVALLETTI MOTORE**

AXLE STANDS AND ENGINE STANDS  
CHANDELLES ET SUPPORT MOTEURS  
UNTERSTELLBÖCKE UND REPARATURSTÄNDER

Made in Italy 



# COLONNETTE DI SOSTEGNO

AXLE STANDS

CHANDELLES

UNTERSTELLBÖCKE



**ART. 151**



**ART. 110/C**



**ART. 110**



**ART. 110/B**



**ART. 110/A**

ART.		 MAX mm	 MIN mm	 KG
<b>110</b>	1000 kg	480	280	3
<b>110/A</b>	1000 kg	650	380	4
<b>110/B</b>	3500 kg	740	440	8
<b>110/C</b>	3500 kg	1170	700	11
<b>151</b>	1000 kg	1885	1120	17

**HEAVY  
DUTY**

**15  
TON**



**ART.**



**MAX  
mm**

**MIN  
mm**

**KG**

<b>215</b>	15000 kg	680	470	27
<b>216</b>	15000 kg	1170	680	36



ART. 215



ART. 216



**HEAVY  
DUTY**

**20  
TON**



**ART. 218**



**ART. 217**

ART.				
<b>217</b>	20000 kg	640	410	29
<b>218</b>	20000 kg	1080	670	32

**5  
TON**

**8  
TON**

**12  
TON**



ART. 239/A



ART. 242

ART.				
<b>239</b>	8000 kg	740	450	18
<b>239/A</b>	5000 kg	740	450	13
<b>240</b>	12000 kg	740	450	25
<b>241</b>	8000 kg	1100	650	23
<b>241/A</b>	5000 kg	1100	650	16
<b>242</b>	12000 kg	1100	650	31





ART. 930

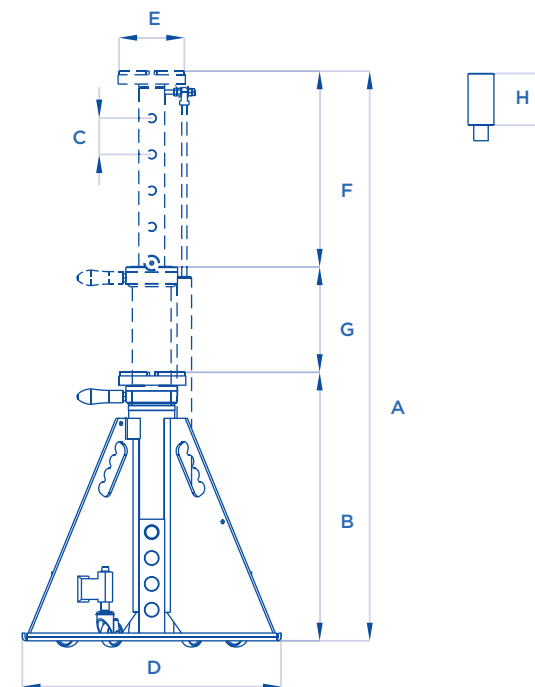

ART.		A  mm	B  mm	C  mm	D  mm	E  mm	F  mm	G  mm	H  mm
930	10000 Kg x2	1120	555	70	500	130	330	215	100

Sollevatore composto da pompa idropneumatica e due colonnette idrauliche, portata 10 ton ciascuna, con funzionamento in coppia o indipendente una dall'altra. Colonnette dotate inoltre di sistema manuale di variazione dell'altezza minima. La soluzione ideale per il sollevamento libera ruote dei veicoli pesanti e per un rapido intervento sugli stessi.

Lift made of one hydropneumatic pump and two hydraulic stands, capacity 10 ton each one, operating in couple or independently one from another. The stands are also equipped with a hand-system to change the minimum height. The ideal solution to lift and free the wheels of heavy vehicles and carry out quick operations.

Elévateur composé d'une pompe hydropneumatique et de deux chandelles hydrauliques d'une portée de 10 ton chacune à fonctionnement par paire ou en individuel. Système de réglage manuel de la hauteur minimum sur chaque chandelle. Idéal pour libérer rapidement les roues ou pour tout type d'intervention rapide sur poids lourds.

Bühne hergestellt mit einer von hydropneumatischen Pumpe und 2 Stück hydraulischen Stützen mit 10 ton Kapazität / Stück, Bedienung zusammen oder einzeln. Stützen sind auch ausgestattet mit einem Hand-System, um die minimale Höhe zu ändern. Die ideale Lösung zum Anheben bzw. die Räder von schweren Fahrzeugen frei zu bekommen und schnelle Reparaturen durchführen zu können.

# CAVALLETTI MOTORE

ENGINE STANDS

SUPPORT MOTEURS

REPARATURSTÄNDER

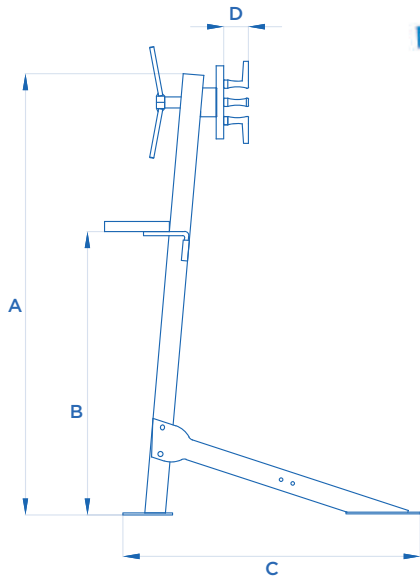

ART. 111

ART.		A mm	B mm	C mm	D mm	KG
111	300 kg	1100	710	570	60	28

CE Made in Italy

## TRACCIATO TECNICO COSTRUTTIVO

- Cavalletto per la revisione dei motori.
- Permette una rotazione di 360° del motore.
- Robusta struttura rinforzata in acciaio saldato.
- Fermo meccanico a vite per bloccare il motore in posizione.
- Braccetti di ancoraggio zincati a regolazione multipla per garantire una compatibilità assoluta.
- Vaschetta porta oggetti di serie.

## RELEVÉ TECHNIQUE

- Chevalet pour l'inspection des véhicules.
- Il permet d'effectuer une rotation à 360° du moteur.
- Structure compacte et robuste en acier soudé.
- Butée mécanique à vis pour bloquer le moteur lorsqu'il est en position.
- Bras d'ancrage galvanisé à réglage multiple pour une préhension parfaite.
- Bac porte outils de série.

## TECHNICAL AND STRUCTURAL LAY-OUT

- Engine stand.
- 360° rotation of the engine.
- Strengthen compact structure made of welded steel.
- Screw mechanical stop to fix the engine in its position.
- Small zinc-coated anchoring arms with a multiple regulation can clasp any engine part.
- Tool tray.

## TECHNISCHE UND KONSTRUKTIV ANGABEN

- Ständer für die Inspektion der Motoren.
- Es erlaubt eine 360° Drehung des Motors.
- Kompakte Struktur aus geschweißtem Stahl.
- Mechanische Schraubverriegelung, um den Motor, wenn es im Position ist, zu blockieren.
- Verzinkten Ankerarme mit mehrfacher Ausrichtung, um eine perfekte Kompatibilität zu sichern.
- Standardmäßig Objektträger.





ART. 219

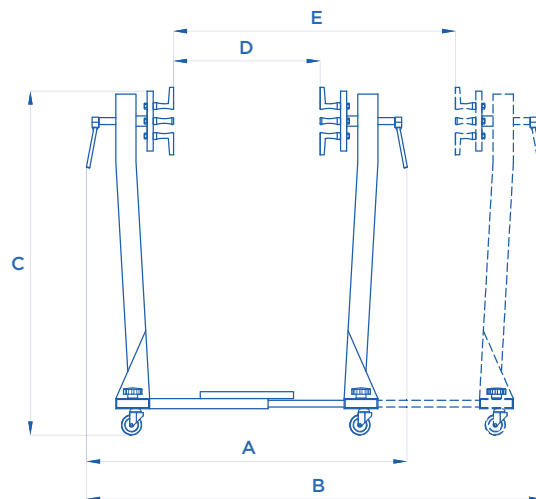

**TRACCIATO TECNICO COSTRUTTIVO**

- Cavalletto doppio per la revisione dei motori.
- Permette una rotazione di 360° del motore.
- Dotato di quattro ruote girevoli con possibilità di bloccaggio.
- Fermo meccanico a vite per bloccare il motore in posizione.
- Braccetti di ancoraggio zincati a regolazione multipla per garantire una compatibilità assoluta.
- Regolabile in lunghezza.
- Vasca di recupero contro la perdita di liquidi di serie.

**RELEVÉ TECHNIQUE**

- Chevalet double pour l'inspection des moteurs.
- Permet d'effectuer une rotation à 360° du moteur.
- Quatre roues pivotantes qui peuvent être bloquées.
- Butée mécanique à vis pour bloquer le moteur en position.
- Bras d'ancrage galvanisés à réglage multiple pour une parfaite préhension.
- Réglable en longueur.
- Bac de récupération pour éviter toute perte de liquides.

**TECHNICAL AND STRUCTURAL LAY-OUT**

- Double engine stand.
- 360° rotation of the engine.
- Four turning wheels that can be blocked when needed.
- Screw mechanical stop to fix the engine in its position.
- Small zinc-coated anchoring arms with a multiple regulation can clasp any engine part.
- Length-adjustable.
- Collector to prevent any liquid loss.

**TECHNISCHE UND KONSTRUKTIV ANGABEN**

- Doppelständer für die Inspektion der Motoren.
- Es erlaubt eine Drehung von 360° des Motors.
- Mit vier lenkbaren Rädern, die blockierbar sind.
- Mechanische Schraubverriegelung, um den Motor, wenn es im Position ist, zu blockieren.
- Verzinkten Ankerarme mit mehrfacher Ausrichtung, um eine perfekte Kompatibilität zu sichern.
- Längsverstellbar.
- Standardmäßige Auffangwanne gegen jeder Flüssigkeitsverlust.

ART.		A mm	B mm	C mm	D mm	E mm	KG
------	--	------	------	------	------	------	----

219	450 kg	755	1120	930	320	685	50
-----	--------	-----	------	-----	-----	-----	----

**ATTREZZO PER LA RIPARAZIONE  
DEI CAMBI DA ADATTARE SUL  
CAVALLETTO ROTATIVO ART. 111**

PROPER TOOL FOR THE REPAIR OF GEABOXES  
TO FIT TO THE ART. 111

APPAREIL POUR LA RÉPARATION DES BOÎTES DE VITESSES  
À ADAPTER SUR LE CHEVALET ROTATIF ART. 111

ZUSATZWERKZEUG FÜR GETRIEBEREPARATUREN  
KANN AUF ART. 111 MONTIERT WERDEN

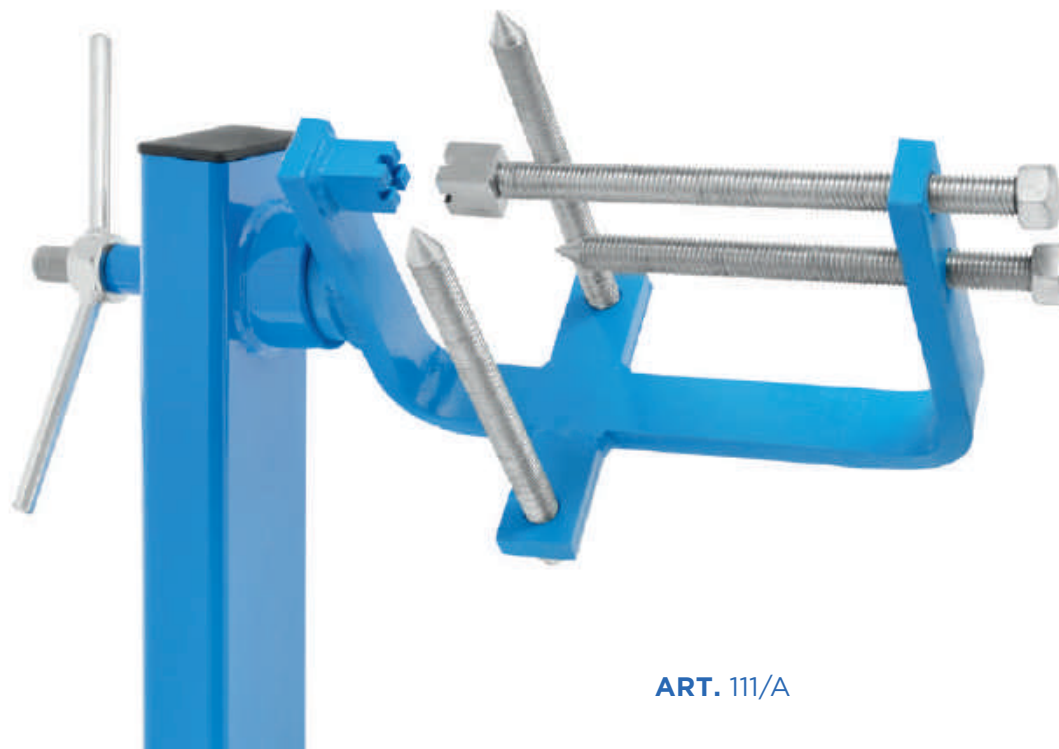

**ART. 111/A**



**ART. 111/B**

**ATTREZZO PER LA RIPARAZIONE  
DELLE TESTATE DA ADATTARE SUL  
CAVALLETTO ROTATIVO ART. 111**

PROPER TOOL FOR THE REPAIR OF ENGINE HEADS TO FIT TO THE ART. 111

APPAREIL POUR LA RÉPARATION DES TÊTES À ADAPTER  
SUR LE CHEVALET ROTATIF ART. 111

ZUSATZWERKZEUG FÜR REPARATUREN AN ZYLINDERKÖPFEN  
KANN AUF ART. 111 MONTIERT WERDEN



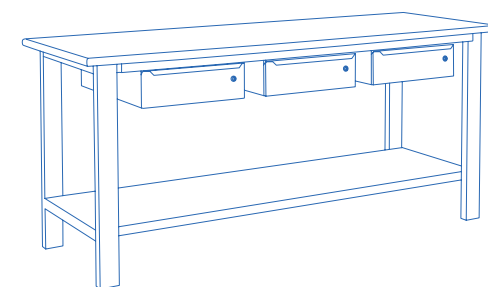

## **CARRELLI E BANCHI DA LAVORO**

TROLLEYS AND WORKBENCHES  
CHARIOTS ET ETABLIS DE TRAVAIL  
WAGEN UND WERKBÄNKE

Made in Italy 







**ART. 109/A**



**\*ART. 109/AS**

**ART. 109/A • 109/AS**  
**CARRELLO PORTA ATTREZZI**

Tool carrying trolley  
Chariot porte-outils  
Werkzeugwagen

<b>ART.</b>					
<b>109/A • 109/AS</b>	120 kg	700 mm	750 mm	350 mm	60 mm

\*Smontabile • demountable • demontables • zerlegbar



**ART. 109/B**





**\*ART. 109/BS**



**\*ART. 1100**

**ART. 109/B • 109/BS • 1100**  
**CARRELLO PORTA ATTREZZI TIPO PESANTE**

Heavy tool carrying trolley  
Chariot porte-outils, lourd  
Werkzeugwagen stabile Ausführung

<b>ART.</b>					
<b>109/B • 109/BS</b>	150 kg	800 mm	750 mm	420 mm	80 mm
<b>1100</b>	150 kg	905 mm	785 mm	445 mm	100 mm

\*Smontabile • demountable • demontables • zerlegbar







**ART. 109/C**



**\*ART. 109/CS**

**ART. 109/C • 109/CS**  
**CARRELLO PORTA ATTREZZI TIPO PESANTE, CON CASSETTO**

Heavy tool carrying trolley with drawer  
Chariot porte-outils, lourd avec tiroir  
Werkzeugwagen stabile Ausführung mit abschließbarer Schublade

<b>ART.</b>					
<b>109/C • 109/CS</b>	150 kg	800 mm	750 mm	420 mm	80 mm

\*Smontabile • demountable • demontables • zerlegbar



**ART. 208**



**\*ART. 208/S**

**ART. 208 • 208/S**  
**CARRELLO GIGANTE A TRE PIANI**

Three-shelf giant trolley  
Chariot geant à trois etages  
Tischwagen mit drei flächen stabile ausführung

<b>ART.</b>					
<b>208 • 208/S</b>	180 kg	1000	830	600	125

\*Smontabile • demountable • demontables • zerlegbar



**ART. 209**



**\*ART. 209/S**

**ART. 209 • 209/S**  
**CARRELLO GIGANTE A TRE PIANI, CON CASSETTO**

Three-shelf giant trolley with drawer  
Chariot geant à trois etages et tiroir  
Tischwagen mit drei Flächen und einer abschliessbaren Schublade

<b>ART.</b>					
<b>209 • 209/S</b>	180 kg	1000	830	600	125

\*Smontabile • demountable • demontables • zerlegbar







**ART. 211**



**\*ART. 211/A**

**ART. 211 • 211/A**  
**CARRELLO CON SPONDE E RETE METALLICA PERIMETRALE**

Sideboarded trolley with external wire net  
Chariot a bords hauts grillagés  
Metallgitterwagen

<b>ART.</b>					
<b>211</b>	250 kg	1000	850	600	125
<b>211/A</b>	250 kg	1020	950	600	125

\*Smontabile • demountable • demontables • zerlegbar







**ART. 207**  
**CARRELLO**  
**CON SPONDA**

Sideboarded trolley  
Chariot avec dossier  
Wagen mit Stützwand



**ART. 207**

ART.					
		mm	mm	mm	mm
<b>207</b>	250 kg	1000	900	600	125
<b>210</b>	200 kg	800	900	450	100
<b>600</b>	75 kg	910	930	400	

**ART. 210**  
**CARRELLO CHIUSO PORTA ATTREZZI**  
**A QUATTRO PIANI CON SERRATURA**

Four-shelf closed tool carrying trolley with lock  
Chariot porte-outils a quatre etages avec termeture  
Fahrbarer, abschliessbarer Werkzeugschrank mit Griff



**ART. 210**

**ART. 600**  
**CARRELLO ECOLOGICO**

Ecological trolley  
Chariot écologique  
Öko-Wagen



**ART. 600**

**ART. 099**  
**SDRAIO**

Cradle  
Chariot de visite  
Rollbrett



ART.			
		mm	mm
<b>099</b>	150 kg	1000	440
<b>099/B</b>	150 Kg	1000	440

**ART. 099/B**  
**SDRAIO CON STRUTTURA IN TUBOLARE**  
**E SCHIENALE COMPLETAMENTE IMBOTTITO**

Cradle with tubular structure and completely stuffed back  
Chariot de visite, à structure tubulaire et dossier entièrement rembourré  
Liegeschlitten mit rohrförmigem Rahmen, vollständig gepolstert



**ART. 1108**  
**SCRIVIMPIEDI**

Write-upright  
Ecrire-de-but  
Schreibpult

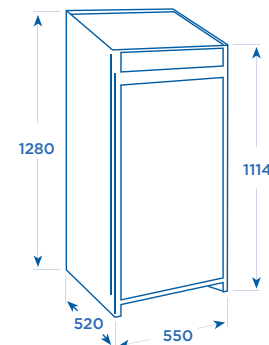

**ART. 092**  
**CARRELLO MILLEUSI**

Several uses trolley  
Chariot multi-usages  
Sackkarre



**ART.**  
**092** | 300 kg | 200

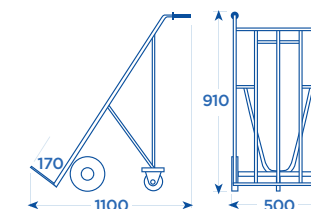

**ART. 095**  
**CARRELLO**  
**PORTA BOMBOLE**

Cylinder holder trolley  
Chariot porte-bonbonnes  
Gasflaschenwagen



**ART.**  
**095** | 200 kg | 250

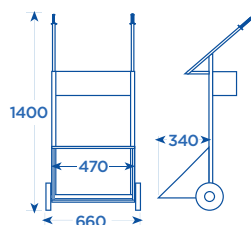

**ART. 095/A**  
**CARRELLO**  
**PORTA BOMBOLA**

Cylinder holder trolley  
Chariot porte-bonbonne  
Gasflaschenwagen



**ART.**  
**095/A** | 200 kg | 250

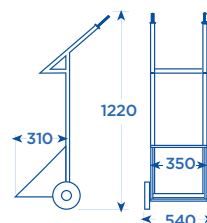

**ART. 212**  
**CARRELLO**  
**PORTA SACCHI**

Sack carrying trolley  
Chariot porte-sac  
Sackkarre



**ART.**  
**212** | 200 kg | 200

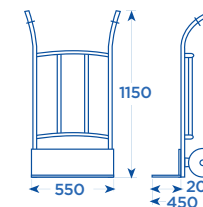

**ART. 213  
CARRELLO  
PORTA CASSE**

Case carrying trolley  
Chariot porte-caisses  
Sackkarre

ART.    
213 | 200 kg | 200

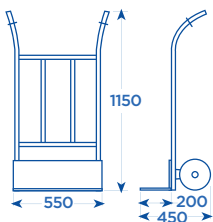

Tipo pesante • Heavy-type • Type-lourd • Schwere ausführung

**ART. 214  
CARRELLO  
PORTA CASSE**

Case carrying trolley  
Chariot porte-caisses  
Sackkarre

ART.    
214 | 100 kg | 200

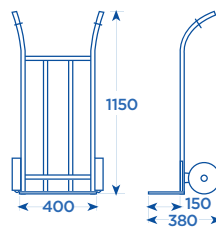

Tipo leggero • Light-type • Type-leger • Leichte ausführung

**ART. 214/A  
CARRELLO MULTIUSO  
PER TRASPORTO SU SCALE**

Multipurpose trolley for transport on stairs  
Chariot multi-usages pour transport sur escalier  
Multifunktions-Sackkarre, speziell geeignet für Treppen

ART.    
214/A | 250 kg | 150

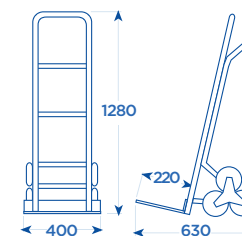

**ART. 214/B  
CARRELLO PORTA  
CASSE STRETTO**

Case carrying trolley tight  
Chariot porte-caisses étroit  
Enge Sackkarre

ART.    
214/B | 250 kg | 260

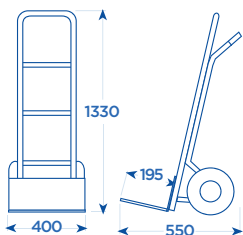

Tipo pesante • Heavy-type • Type-lourd • Schwere ausführung

**ART. 214/C  
CARRELLO PORTA  
CASSE LARGO**

Case carrying trolley wide  
Chariot porte-caisses large  
Breite Sackkarre

ART.    
214/C | 250 kg | 260

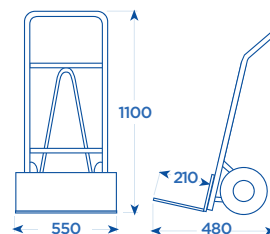

Tipo pesante • Heavy-type • Type-lourd • Schwere ausführung

**ART. 214/D  
CARRELLO PORTA  
SACCHI E PORTA FUSTI**

Drum and sack carrying trolley  
Chariot porte sacs et futs  
Faß-/Sackkarre

ART.    
214/D | 250 kg | 260

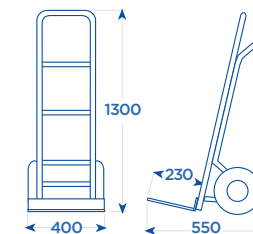

## BANCHI DA LAVORO

Workbenches  
Etablis de travail  
Werkbänke



ART. 1000



ART. 1002



ART. 1004







ART. 1000/PL



ART. 1002/PL



ART. 1004/PL

ART.		Planale in legno Wooden-top Plan de travail en bois Holzoberfläche	Numero di cassetti Number of drawers Nombre de tiroirs Anzahl der Schubladen			
				mm	mm	mm
1000	700 kg		1	1000	850	700
1000/PL	700 kg	✓	1	1000	880	700
1001	600 kg		1	1500	850	700
1001/PL	600 kg	✓	1	1500	880	700
1002	600 kg		2	1500	850	700
1002/PL	600 kg	✓	2	1500	880	700
1003	400 kg		2	2000	850	700
1003/PL	400 kg	✓	2	2000	880	700
1004	400 kg		3	2000	850	700
1004/PL	400 kg	✓	3	2000	880	700

Vengono forniti in versione smontabile per una più facile e razionale gestione del trasporto e dell'immagazzinaggio. Possono essere forniti con pianale in lamiera o con pianale in legno. Tutti i cassetti sono dotati di serratura e lo scorrimento avviene su guide con cuscinetto. Verniciatura a polvere epossidica.

They are supplied in dismantlable version for an easier and more rational transport and storage. They can be supplied complete with steel-top or complete with wooden-top. All drawers are equipped with lock and their sliding is on bearing-guides. Epoxy-powdered painting.

Livrés en version démontable pour faciliter transport et stockage. Livrés avec plan de travail en tôle ou avec plan de travail en bois. Tiroirs sur glissières et équipés de serrure. Peinture epoxy.

Die Werkbänke werden in zerlegtem Zustand geliefert. Die Oberfläche ist in Holz-oder Stahl-Ausführung. Alle Schubladen sind abschließbar und kugelgelagert. Die Oberfläche ist epoxidpulverbeschichtet.

## ACCESSORI

ACCESSORIES  
ACCESSOIRES  
ZUBEHÖR





ART. 1052

## PANNELLI

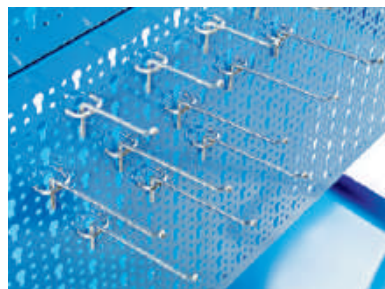
Panels • Panneaux • Paneele



ART.			
		mm	mm
1050		940	440
1051		975	975
1052	✓	975	870
1053	✓	1445	870

## CASSETTI

Drawer units • Caisson-Tiroirs  
Schubkastenelemente



ART. 1011

		
mm	mm	mm
130	530	400

## GANCI

Hooks • Crochets • Haken



ART. 1070  
200 mm

ART. 1071  
150 mm

ART. 1072  
120 mm

ART. 1073  
80 mm

ART. 1074  
60 mm

ART. 1075  
con occhiello  
with eyelet  
avec oeillet  
mit Öse



ART. 1076  
150 mm

ART. 1077  
100 mm

**ART. C51**  
**CARRELLO A QUATTRO RIPIANI,**  
**COMPLETO DI PANNELLO PORTAUTENSILI**

Four-level-trolley, equipped with tool-holding panel  
 Chariot à quatre étages avec panneau porte-outils  
 Wagen mit 4 Ablageflächen und einer  
 Werkzeug-Lochaufnahmeplatte

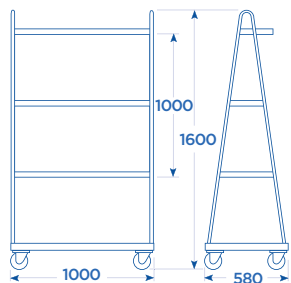

**ART. C51/A**  
**CARRELLO A QUATTRO RIPIANI, COMPLETO**  
**DI DOPPIO PANNELLO PORTAUTENSILI**

Four-level-trolley, complete with double tool-holding panel  
 Chariot à quatre étages avec deux panneaux porte-outils  
 Wagen mit 4 Ablageflächen und 2 Werkzeug-Lochaufnahmeplatten

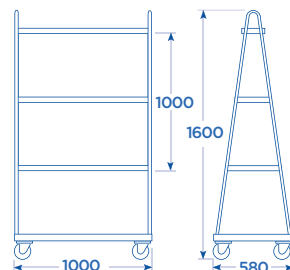

**ART. C52**  
**CARRELLO A DUE RIPIANI, COMPLETO**  
**DI PANNELLO PORTAUTENSILI**

Two-level-trolley, equipped with tool-holding panel  
 Chariot à deux étages avec panneau porte-outils  
 Wagen mit 2 Ablageflächen und einer zweiseitigen  
 Werkzeug-Lochaufnahmeplatte

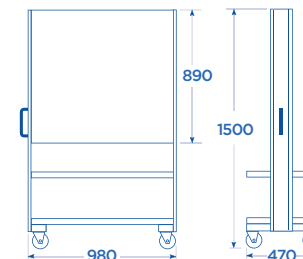

**ART. C53 • C54 • C55**  
**PANNELLI PORTA UTENSILI**  
**COMPOSTI DA PANNELLI BIFACCIALI**

Tool-holding panels equipped with byfacial panels  
 Panneaux porte-outils. Équipés de panneaux double face

Werkzeug-Lochaufnahmeplatten mit doppelseitigen  
 Werkzeug-Lochaufnahmeplatten

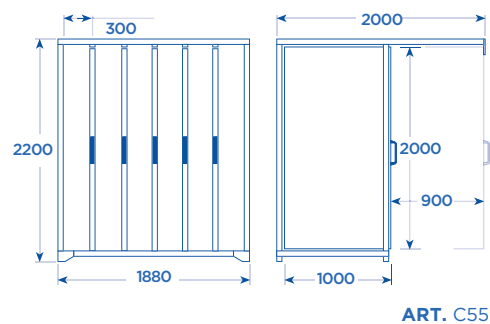
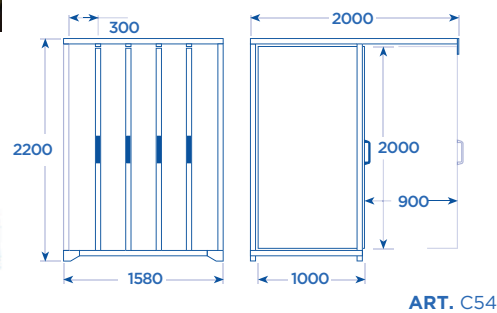
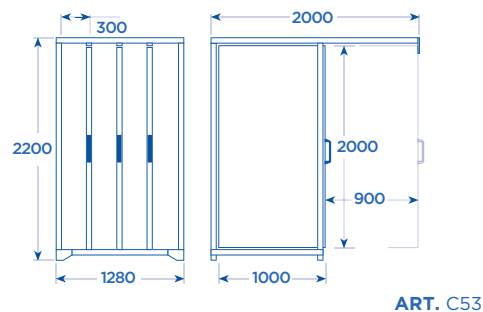

ART.	m <sup>2</sup>	Pannelli bifacciali Byfacial panels Panneaux double face Doppelseitigen Werkzeug
<b>C53</b>	12	3
<b>C54</b>	16	4
<b>C55</b>	20	5



**ART. C55**

**ACCESSORI**

ACCESSORIES  
 ACCESSOIRES  
 ZUBEHÖR

**GANCI**

Hooks • Crochets • Haken

**ART. 1070**  
200 mm

**ART. 1071**  
150 mm

**ART. 1072**  
120 mm

**ART. 1073**  
80 mm

**ART. 1074**  
60 mm

**ART. 1075**  
con occhiello  
with eyelet  
avec oeillet  
mit Öse

**ART. 1076**  
150 mm

**ART. 1077**  
100 mm

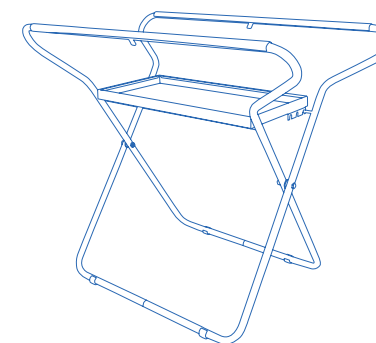

**ATTREZZI SPECIALI  
PER LA CARROZZERIA**

SPECIAL EQUIPMENT FOR CAR-BODY SHOP  
OUTILS DE CARROSSIER  
SPEZIALGERÄTE FÜR KAROSSERIEARBEITEN

Made in Italy 





ART. 250

## CARRELLO JOLLY

JOLLY TROLLEY  
 CHARIOT JOLLY  
 JOLLY RANGIERWAGEN

### ART. 250/A • 250/B

con 2 ruote frenanti  
 with 2 braking wheels  
 avec 2 roues freinantes  
 mit 2 blockierbaren Rädern



ART.					
		mm	mm	mm	mm
<b>250</b>	800 kg	600	330	1300	200
<b>250/A</b>	800 Kg	600	330	1300	200
<b>250/B</b>	1200 kg	600	300	1880	200



ART. 250/A



ART. 250/B



### ART. 250 • 250/A • 250/B

Lo spostamento di autovetture sprovviste di meccanica anteriore o posteriore non è più un problema. Questo carrello è stato studiato per evitare qualsiasi disagio. Il grosso diametro delle quattro ruote pivoettanti impiegate, fa sì che gli spostamenti risultino estremamente scorrevoli sia su grigliati, che su pavimenti leggermente sconnessi. Va inoltre sottolineato che il carrello può tranquillamente essere lasciato anche nei forni di verniciatura, senza che le ruote vengano danneggiate. Le stesse infatti, essendo in nylon, sopportano tranquillamente forti temperature fino a 90 - 100°.

The moving of vehicles without front or rear mechanics is no longer a problem. This trolley has been studied to avoid any inconvenience. The same result is obtained also if the vehicle is without both front and rear mechanics, by using two trolleys. The wide diameter of the four rotating wheels used for the trolley makes it easy to move the vehicles on the trolley both on floors with grates than on slightly uneven floors. It is important to point out that the trolley can be left in the painting ovens without suffering any damage to the wheels. In fact, being wheels in nylon, they can withstand temperatures up to 90 - 100 centigrades.

Le déplacement des voitures sans mécanique avant ou arrière n'est plus un problème. Ce chariot est spécialement conçu à cet effet. Si la voiture est aussi dépourvue complètement de mécanique, on obtient le même résultat par l'emploi de deux chariots. Le diamètre important des roues pivotantes permet le déplacement en douceur aussi bien sur un sol légèrement inégal que pourvu de grilles. Le chariot peut être également laissé en cabine de peinture, sans risque de dommages pour les roues. Celles-ci sont en effet en nylon et supportent des températures allant jusqu'à 90 - 100°.

Mit Hilfe dieses Gerätes können Fahrzeuge ohne vordere oder hintere Achse problemlos bewegt werden. Fehlen die Achsen komplett, so werden zwei dieser Transportwagen verwendet. Vier große schwenkbare Räder sorgen für ein gutes Fahrverhalten auch auf unebenem Boden. Der Transportwagen ist mit hitzebeständigen Rädern ausgestattet - Belastbarkeit 90 - 100°; er ist daher bestens für die Verwendung in Lackieranlagen geeignet.

## TRAVERSE REGOLABILI

ADJUSTABLE CROSS-MEMBER

TRAVERSE REGLABLE

AUSZIEHBABE TRAVERSE



ART. 275

### ART. 275

Le traverse "Super Condor" sono state create per rendere agevole il sollevamento del motore. L'utilizzo, estremamente semplice, avviene ancorando, tramite catene, il motore alla vite senza fine. Questi attrezzi possono essere impiegati per ogni tipo di autovettura a motore anteriore, grazie alla regolazione delle due prolunghie in senso laterale. Oltre a una molteplice serie di impieghi, risultano estremamente indicati per lo smontaggio dell'asse anteriore del motore.

"Super Condor" have been realized to make removing of motors easy. The use takes place anchoring, by means of chains, the motor to the worm screw. Thanks to the extensible cross-member, these implements can be used for any kind of cars with front motor. In addition to the many and various uses, they are definitely advisable for the dismantling of the driving front axle.

Les "Super Condor" ont été réalisées pour faciliter l'enlèvement du moteur. L'usage très simple, s'effectue en ancrant le moteur à la vis sans fin par les chaînes. Grâce aux traverses extensibles, ces appareils peuvent être employés pour tous types de voitures à moteur avant. Outre ces divers emplois, ils sont particulièrement indiqués pour le démontage de l'essieu avant du moteur.

Dieses Gerät ist entwickelt worden, um das Herausheben des Motors zu erleichtern. Der Motor wird ganz einfach mit Ketten an der Spindel befestigt. Dank der seitlichen Verlängerungsmöglichkeit der Quertraverse kann diese praktisch bei jedem Fahrzeugtyp verwendet werden. Außerdem ist dieses Gerät besonders praktisch für den Ausbau der vorderen Antriebsachse.

### ART. 275/A

Regolabile anche in altezza • Adjustable also in height  
Reglable aussi en hauteur • Auch höhenverstellbar

ART.		MAX mm	MIN mm
275	500 kg	1600	920
275/A	500 Kg	1600	920

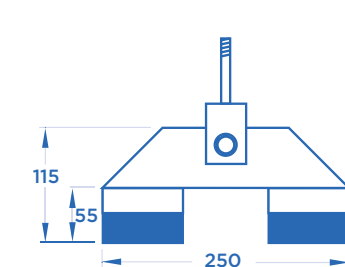

ART. 275

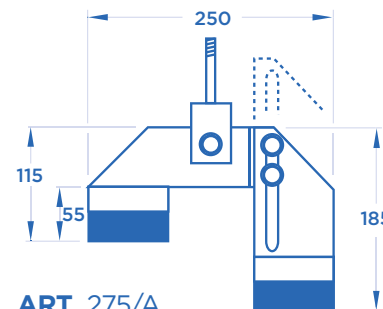

ART. 275/A

**CAVALLETTO  
MULTIPRATIC**

MULTIPRATIC STAND  
CHEVALET MULTIPRATIC  
UNIVERSALSTÄNDER



**ART. 274**

Una nuova idea per dare un notevole aiuto al carrozziere. Con l'impiego di questo particolare attrezzo si possono comodamente eseguire operazioni di raddrizzatura, carteggiatura e verniciatura di cofani, portiere, parafanghi e di tutte le altre parti asportabili della carrozzeria. Viene dotato di serie sia di braccio presa che di meccanica snodata.

A new idea to make body-maker's job easier. By using this particular implement, one can comfortably execute straightening, sanding and painting of bonnets, cardoors, mudguards and of all other removable parts of the car-body. It is supplied with arm and articulated mechanics.

Une nouvelle idée pour rendre le travail du carrossier plus facile. Avec l'emploi de cet appareil particulier on peut exécuter en toute commodité les opérations de redressage, lissage et vernissage de capots, portières, ailes et toutes autres parties amovibles du châssis. Il est fourni avec bras de prise et mécanique articulée.

Ein neues Hilfsgerät für den Karosseriefachmann. Mit diesem Gerät können bequem Richt-Schleif- und Lackierarbeiten an Motorhauben, Türen, Kotflügeln und allen anderen abnehmbaren Teilen der Karosserie vorgenommen werden. Standardausstattung bestehend aus: Aufspannarm und Schwenkmechanik.

**CAVALLETTO  
POLIFUNZIONALE**  
MULTIFUNCTION STAND  
CHEVALET MULTI-FONCTION  
MULTIFUNKTIONS-STÄNDER



**ART. 274/A**



**ART. 274/A**

Con possibilità di reclinazione a 360°, registrabile a pedale e dotato di ruote per facili spostamenti.

With possibility to be reclined at 360°, adjustable by pedal and equipped with wheels for easy movements.

Inclinable à 360°, réglage par pédale et équipé de roues.

Fahrbarer vielseitig einstellbarer Universal-Aufnahmeständer; durch ein Fußpedal verstellbar, um 360° drehbar.

**CAVALLETTO SPEEDY  
REGOLAZIONE A TRE POSIZIONI**

SPEEDY STAND THREE POSITIONS ADJUSTMENT  
CHEVALET SPEEDY REGLABLE EN TROIS POSITIONS  
SPEEDY STÄNDER MIT 3 VERSCHIEDENEN VERSTELLMÖGLICHKEITEN

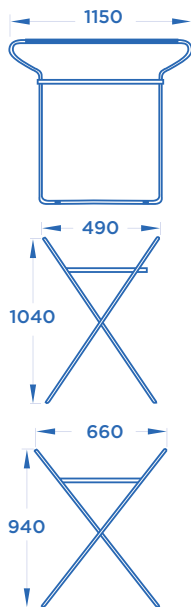

ART. 381

**CAVALLETTO MAXI SPEEDY  
A PLURIREGOLAZIONI**

MAXI SPEEDY STAND WITH DIFFERENT REGULATIONS  
CHEVALET MAXI SPEEDY AVEC DIVERS REGLAGES  
MAXI SPEEDY STÄNDER MIT VERSCHIEDENEN VERSTELLMÖGLICHKEITEN

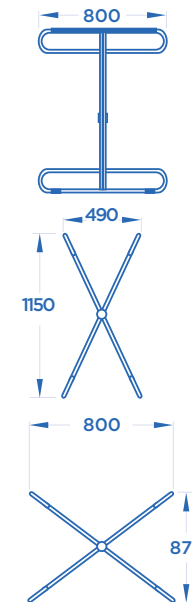

ART. 381/A



ART. 379

**STRUMENTO DI MISURAZIONE TELESCOPICO**

TELESCOPIC MEASUREMENT INSTRUMENT  
INSTRUMENT DE MESURE TÉLESCOPIQUE  
AUSZIEHBARES MESSINSTRUMENT



ART. 379

Strumento di misurazione telescopico a tripla sfilata, con doppio riscontro di lettura e braccetti di puntamento millimetrati.

Three stages telescopic measurement instrument, with double reading checking and little arms for spot-welding divided into millimeters.

Instrument de mesure télescopique à trois files, avec double table de lecture et bras d'appuis millimétrés.

3-stufig ausziehbares Messinstrument mit von 2 Seiten ablesbarer Skala (in mm-Einteilung) und kleinen Armen zur punktgenauen Vermessung.

## CARRELLO PER RECUPERO VETTURE DA ISSARE SU CARROATTREZZI

TROLLEY FOR COLLECTING CARS TO BE LIFTED ONTO WRECKER

CHARIOT DE RÉCUPÉRATION VOITURES À HISSER SUR LE CHARIOT DE DÉPANNAGE

WAGEN ZUR AUFNAHME VON FAHRZEUGEN FÜR DEN GEBRAUCH AUF ABSCHLEPPFAHRZEUGEN

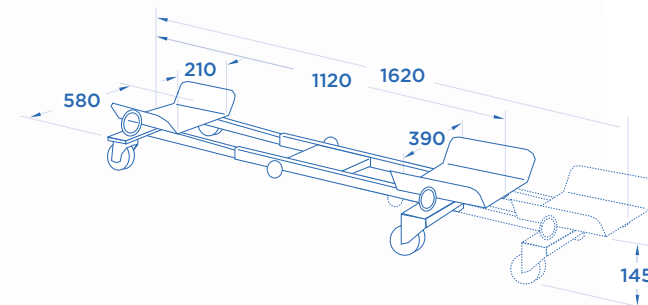

ART. 388/C



388/C



700 Kg



100

SLALOM LINE



ART. 388

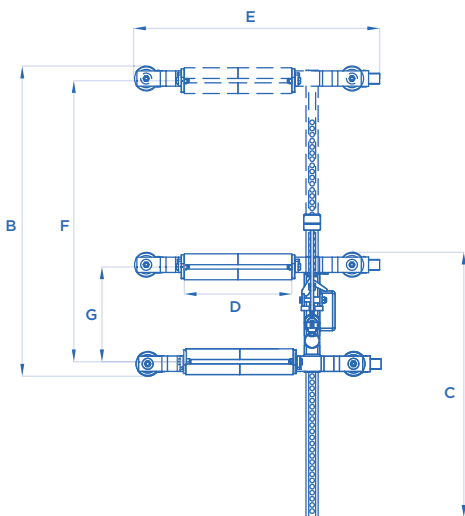

ART.		A mm	B mm	C mm	D mm	E mm	F mm	G mm	KG
388	550 Kg	150	820	710	200	635	650	220	19

ART. 388

Per manovrare e posizionare ogni tipo di vettura in spazi ristretti. Particolarmente indicato per carrozzerie, saloni d'auto, officine di riparazione e garages. Esecuzione con pedale destro o sinistro per la risoluzione di ogni tipo di problema e la possibilità d'impiego anche con ruote sottosterzo. I rulli e la struttura di base del carrello sono stati studiati per sollevare pneumatici fino a **220 mm.** di larghezza.

The trolley can be used to move and position all types of vehicles in narrow spaces. It is particularly suitable for body shops, motor shows, repair shops and garages. Movement by right or left pedal allows to solve any kind of problem and it can be used even when the vehicle wheels are fully turned. The rollers and the base structure have been designed to lift tires up to **220 mm.** width.

Conçu pour manoeuvrer et positionner facilement tous types de voitures dans les espaces les plus restreints. Particulièrement indiqué pour carrosseries, salons d'exposition et garages. Se manoeuvre avec pédale droite ou gauche selon la situation et fonctionne même quand les roues du véhicule sont braquées à fond. Rouleaux et structure de base du chariot étudiés pour soulever des pneus jusqu'à **220 mm.** de largeur.

Der Wagen ist besonders geeignet, wenn Autos unter beengten Platzverhältnissen bewegt werden müssen, d.h. insbesondere in Karosserie-Werkstätten, Ausstellungsräumen und Garagen. Durch Ausführung mit rechtem und linkem Pedal wird jegliches Problem des Anwenders gelöst. Der Wagen ist so gebaut worden, dass das Anheben von Reifen bis zu einer Höhe von **220 mm.** möglich ist.





ART. 388/SW

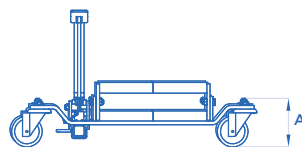
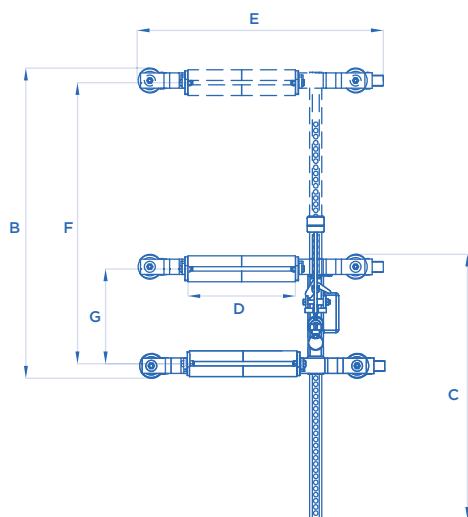

ART.		A mm	B mm	C mm	D mm	E mm	F mm	G mm	KG
388/SW	550 Kg	150	820	710	200	635	650	220	21

## ART. 388/SW

Per manovrare e posizionare ogni tipo di vettura in spazi ristretti. Particolarmente indicato per carrozzerie, saloni d'auto, officine di riparazione e garages. Esecuzione con pedale destro o sinistro per la risoluzione di ogni tipo di problema e la possibilità d'impiego anche con ruote sottosterzo.

I rulli e la struttura di base del carrello sono stati studiati per sollevare pneumatici fino a **280 mm.** di larghezza.

The trolley can be used to move and position all types of vehicles in narrow spaces. It is particularly suitable for body shops, motor shows, repair shops and garages. Movement by right or left pedal allows to solve any kind of problem. It can be used even when the vehicle wheels are fully turned.

The rollers and the base structure have been designed to lift tires up to **280 mm.** width.

Conçu pour manœuvrer et positionner facilement tous types de voitures dans les espaces les plus restreints. Particulièrement indiqué pour carrosseries, salons d'exposition et garages. Se manœuvrer avec pédale droite ou gauche selon la situation et fonctionne même quand les roues du véhicule sont braquées à fond. Rouleaux et structure de base du chariot étudiés pour soulever des pneus jusqu'à **280 mm.** de largeur.

Der Wagen ist besonders geeignet, wenn Autos unter beengten Platzverhältnissen bewegt werden müssen, d.h. insbesondere in Karosserie-Werkstätten, Ausstellungsräumen und Garagen. Durch Ausführung mit rechtem und linkem Pedal wird jegliches Problem des Anwenders gelöst. Der Wagen ist so gebaut worden, daß das Anheben von Reifen bis zu einer Höhe von **280 mm.** möglich ist.







ART. 388/A

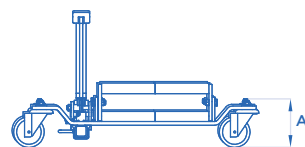
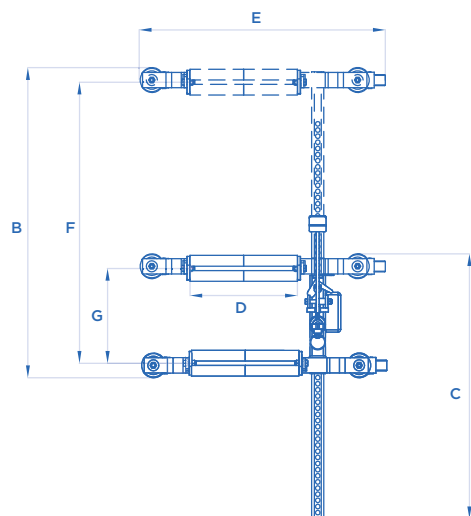

ART.		A mm	B mm	C mm	D mm	E mm	F mm	G mm	KG
388/A	550 Kg	130	820	710	200	400	650	220	18

### ART. 388/A

Attrezzo per carico e scarico di autovetture sinistrate per qualsiasi tipo di carroattrezzi. I rulli e la struttura di base del carrello sono stati studiati per sollevare pneumatici fino a **220 mm.** di larghezza.

Tool for loading and unloading damaged vehicles on any kind of tow truck. The rollers and the base structure have been designed to lift tires up to **220 mm.** width.

Appareil pour le chargement et le déchargement des voitures accidentées pour n'importe quelle dépanneuse. Rouleaux et structure de base du chariot étudiés pour soulever des pneus jusqu'à **220 mm.** de largeur.

Mit Hilfe dieses Wagens können beschädigte PKW problemlos auf Abschleppfahrzeuge verladen werden.

Der Wagen ist so gebaut worden, dass das Anheben von Reifen bis zu einer Höhe von **220 mm.** möglich ist.



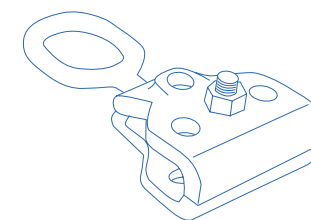

## **UTENSILI PROFESSIONALI**

PROFESSIONAL TOOLS  
OUTILS PROFESSIONNELS  
KAROSSERIE-RICHTWERKZEUG

Made in Italy 

**ART. 251  
PINZA AUTOBLOCCANTE  
AUTOMATICA**

Fast automatic clamp  
Pince autobloquante automatique  
Zugklemme, selbstspannend (automatisch)

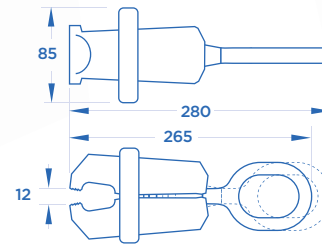

**ART. 276  
PINZA AUTOBLOCCANTE  
AUTOMATICA A TENAGLIA**

Fast selflocking scissor clamp  
Pince à tenailles autobloquante automatique  
Zangenzugklemme, selbstspannend

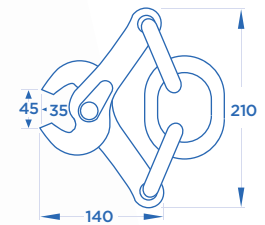

**ART. 277  
PINZA AUTOBLOCCANTE A  
TIRAGGIO PLURIDIREZIONALE**

Selflocking swivel clamp  
Pince autobloquante pluridirectionelle  
Zugklemme, selbstspannend, mit beweglicher Zugöse

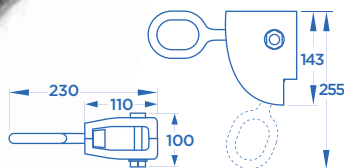

**ART. 277/A  
MINI PINZA AUTOBLOCCANTE  
A TIRAGGIO PLURIDIREZIONALE**

Mini selflocking swivel clamp  
Mini pince autobloquante à traction pluridirectionnelle  
Kleine Zugklemme, selbstspannend

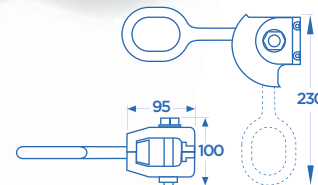

**ART. 278  
PIASTRA PLURIFORATA PER  
TRAZIONE TELAIO**

Multi-drilled pull plate  
Barre de traction à perforations  
Zugbügel mit verschiedenen Befestigungslöcher

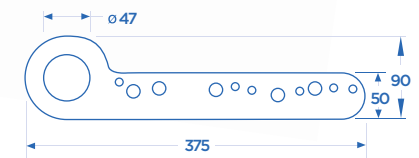

**ART. 279 • 279/A**  
**MORSETTO AUTOSERRANTE**  
**DI TRAZIONE (MM. 100)**

Selflocking clamp width (100 mm.)  
Pince de traction (100 mm.)  
Zugklemme, selbstspannend (100 mm.)

ART. 279/A

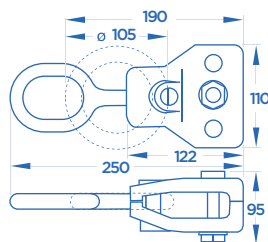

ART. 279

**ART. 280 • 280/A**  
**MORSETTO AUTOSERRANTE**  
**PER AGGOCCIOLATOI (MM. 70)**

Selflocking clamp width (70 mm.)  
Pince de traction (70 mm.)  
Zugklemme, selbstspannend (70 mm.)  
für Regenrinne

ART. 280/A

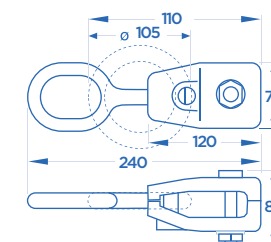

ART. 280

**ART. 281 • 281/A**  
**MORSETTO AUTOSERRANTE**  
**DI TRAZIONE (MM. 45)**

Selflocking clamp width (45 mm.)  
Pince de traction (45 mm.)  
Zugklemme, selbstspannend (45 mm.)

ART. 281/A

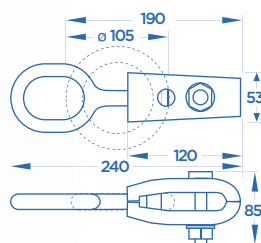

ART. 281

**ART. 282 • 282/A**  
**MORSETTO AUTOSERRANTE**  
**DI TRAZIONE A ANGOLO RETTO**

Selflocking right angle clamp  
Pince de traction à angle droit  
Zugklemme, selbstspannend,  
mit zwei Zugmöglichkeiten

ART. 282/A

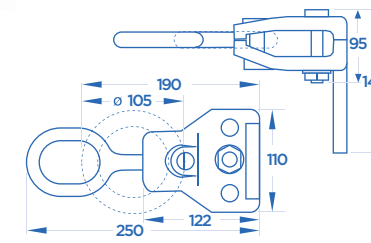

ART. 282

**ART. 285  
BRACCIO A GANCIO CON TRE ATTACCHI  
ADATTABILI, DI CUI UNO FILETTATO**

Arm with 3 adjustable couplings of which one is threaded  
Crampon avec trois attaches dont une fileté  
Zugbügel mit drei anpaßbaren Befestigungsstücken



**ART. 283  
STAFFA DI TRAZIONE  
PER MORSETTI AUTOSERRANTI**

Pull yoke for selflocking clamps  
Axe de traction pour pinces autoserrantes  
Zugbügel für selbstspannende Zugklemmen

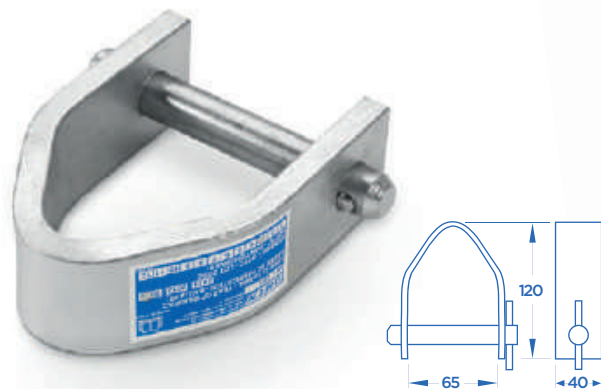

**ART. 393  
MORSETTO A DOPPIO BRACCIO MULTIUSO**

Multipurpose double arm clamp  
Étau à double bras multifonctionnel  
Zugklemme mit vielseitig verwendbarem Doppelarm



**ART. 297  
MORSETTO PICCOLO**

Little clamp  
Petit étau  
Kleine Klemme (mit Ring)

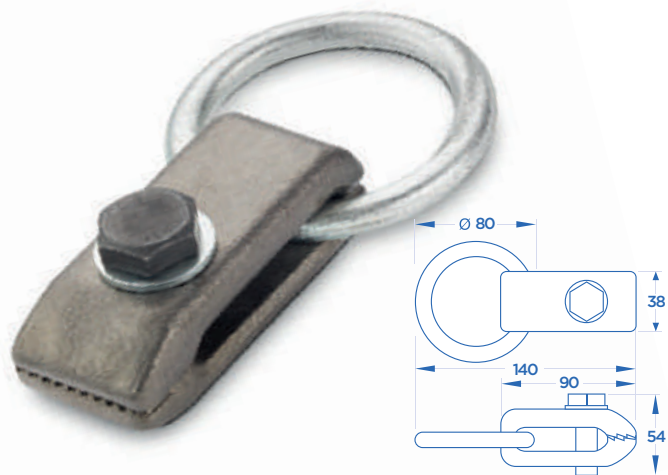

**ART. 299/B  
MORSETTO  
A TENAGLIA**

Pincer clamp  
Étau à tenaille  
Zangenklemme

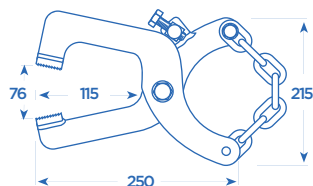

**ART. 299/D  
MORSETTO  
A TENAGLIA**

Pincer clamp  
Étau à tenaille  
Zangenklemme

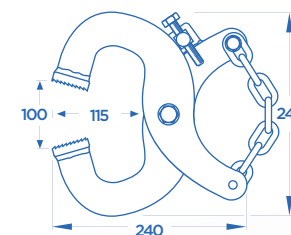

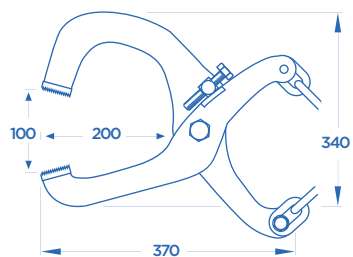

**ART. 299/H  
MORSETTO  
A TENAGLIA**

Pincer clamp  
Étau à tenaille  
Zangenklemme



**ART. 299/M  
MORSETTO  
A TENAGLIA**

Pincer clamp  
Étau à tenaille  
Zangenklemme

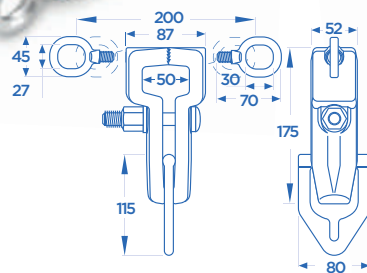

**ART. 295/SP  
MORSETTO AUTOBLOCCANTE AUTOMATICO  
CON GANASCE RIPORTATE (MM. 60)**

Automatic selflocking clamp with inserted jaws (mm. 60)  
Étau autobloquant automatique avec mâchoires (mm. 60)  
Automatisch selbstspannende Zugklemme mit auswechselbaren Backen (60 mm.)

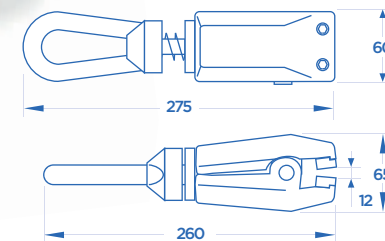

**ART. 299/N  
MORSETTO  
A TENAGLIA**

Pincer clamp  
Étau à tenaille  
Zangenklemme

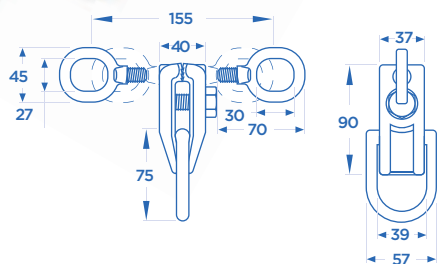

**ART. 299/O  
STAFFATORE PER  
CINGHIE E CATENE**

Molder for belts and chains  
Guide pour chaînes et sangles  
à double traction  
Bügel für Riemen und Ketten

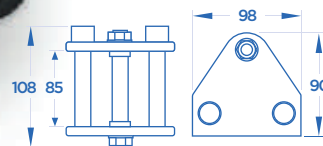

**ART. 296/SP  
MORSETTO AUTOBLOCCANTE AUTOMATICO CON GANASCE  
RIPORTATE (MM. 100)**

Automatic selflocking clamp with inserted jaws (mm. 100)  
Étau autobloquant automatique avec mâchoires (mm. 100)  
Automatisch selbstspannende Zugklemme mit  
auswechselbaren Backen (100 mm.)

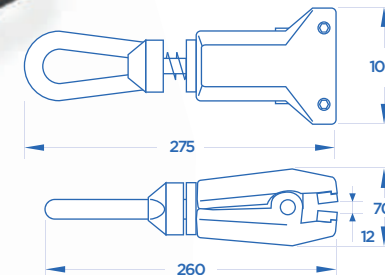

**BELT KIT**



ART.	mm
RIF. A	800
RIF. B	1200
RIF. C	1800
RIF. D	1000



Cinghie in poliestere ad elevata resistenza. Particolarmente indicate per operazioni di tiro in carrozzeria, ben si adattano a molteplici e svariati impieghi. L'estrema flessibilità, duttilità e leggerezza, unite alla elevata capacità ed alla sicurezza d'impiego, ne fanno un indispensabile strumento di lavoro. Le asole terminali rinforzate ben si accoppiano con ganci e catene di nostra produzione.

High resistance belts in polyester. Particularly suited for pulling operations in car's body-work, and adapted for multiple and various uses. The extreme flexibility and lightness together with the high capacity and use safety, make it an indispensable work instrument. The straightened terminal holes fit well with hooks and chains produced by us.

Courroie en polyester à haute résistance. Par ses emplois variés et multiples, elle est particulièrement indiquée dans les opérations de tirage en carrosserie. Son extrême flexibilité, sa légèreté s'unissent à une capacité de tension élevée et à une sécurité d'emploi pour en faire un indispensable instrument de travail. Les boutonnières terminales renforcées s'adaptent aux crochets et chaînes de notre production.

Hochwiderstandsfähige Gurte aus Polyester. Geeignet für eine Vielzahl von Verwendungsmöglichkeiten, insbesondere für Karosserie-Zugarbeiten. Extreme Flexibilität, leichtes Gewicht sowie hohe Belastbarkeit und Sicherheit in der Anwendung machen sie zu einem unentbehrlichen Arbeitsgerät. Die Klemmenaufnahmen der Gurte passen für alle von OMCN hergestellten Haken und Ketten.

## CATENE E GANCI IN ACCIAIO LEGATO AD ELEVATA RESISTENZA, BONIFICATE, COLLAUDATE, CROMATE

CHROMED, TESTED AND TEMPERED CHAINS AND HOOKS IN HIGH RESISTANCE ALLOY STEEL

CHAÎNES ET CROCHETS EN ACIER ALLIÉ HAUTE RESISTANCE, TREMPÉES, TESTÉES, CHROMÉES

VERCHROMTE, GEHÄRTETE UND GEPRÜFTE KETTEN UND HAKEN AUS HOCHFESTER STAHLLEGIERUNG

## CAVO SICURO

Safety cable  
Câble de sûreté  
Sicherheitskabel



ART.

mm

**325**

1500

**325/A**

2000

**325/B**

2500

**325/C**

3000



## CON 1 GANCIO

with 1 hook  
1 crochet  
mit 1 Haken

ART.

mm

**300**

1500

**301**

2000

**302**

2500

**303**

3000



## CON 2 GANCI

with 2 hooks  
2 crochets  
mit 2 Haken

ART.

mm

**304**

1500

**305**

2000

**306**

2500

**307**

3000





**ART. 318**  
**DOPPIO GANCIO PER**  
**AGGANCIAMENTO**  
**E ASSEMBLAGGIO CATENE**

Twin hook to assemble chains  
Deux crochets simples pour l'assemblage de deux chaînes  
Doppelhaken zur Kettenverbindung



**ART. 316**  
**GANCIO CON ATTACCO**  
**A FORCELLA**

Hook with fork coupling  
Crochet simple avec axe à goupille en acier  
Haken



**ART. 323**  
**ACCORCIATORE**  
**E CONGIUNTORE DI CATENA**

Chain joiner and shortner  
Double oeillet pour attache rapide de deux chaînes  
Kettenverkürzer und Verbindungsglied

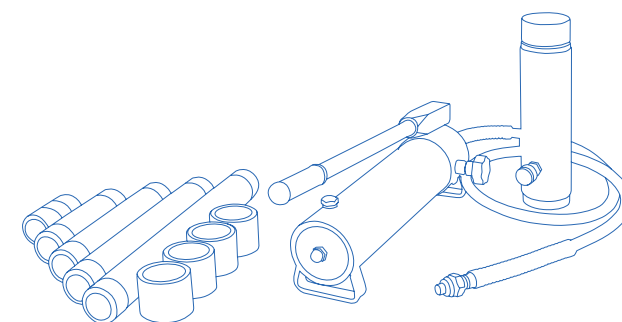

**MARTINETTI IDRAULICI  
PER CARROZZERIA**

HYDRAULIC JACKS FOR CAR-BODY SHOP  
VERINS HYDRAULIQUES POUR CARROSSERIE  
HYDRAULISCHE RICHTSÄTZE FÜR DEN KAROSSERIEBAU

Made in Italy 

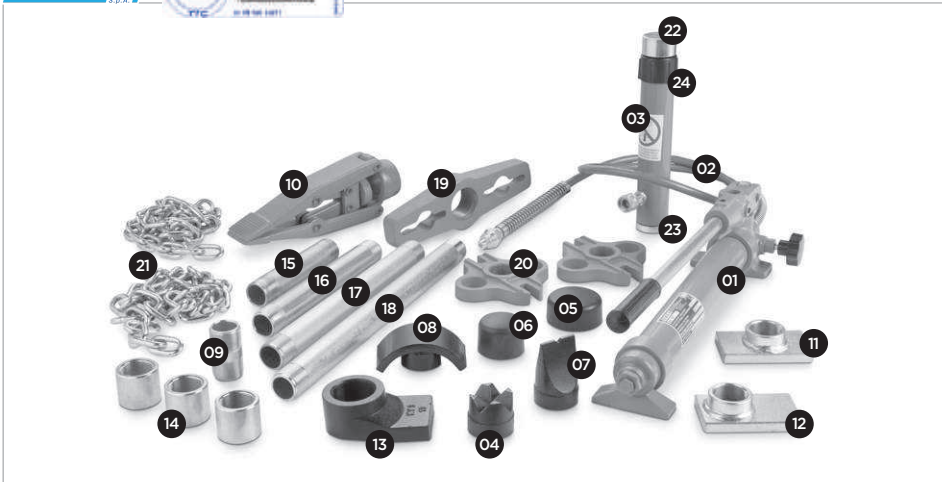

# TITANIK LINE

## MARTINETTI IDRAULICI PER CARROZZERIA

HYDRAULIC JACKS FOR CAR-BODY SHOP

VERINS HYDRAULIQUES POUR CARROSSERIE

HYDRAULISCHE RICHTSÄTZE FÜR DEN KAROSSERIEBAU

**⚠** La capacità è da intendersi al 50% della capacità nominale quando vengono impiegate le prolunghe in dotazione e/o i relativi accessori.  
Capacity down to 50% rated capacity when used with outfit extensions and/or accessories.  
Utilisation avec rallonges et/ou accessoires fournis: capacité à 50% de la capacité déclarée.  
Tragkraft minus 50% der deklarierten Tragkraft wenn gelieferte Verlängerungen und/oder Zubehör benutzt werden.

### ART. 101 • 102 • 102 EXPORT

**01** Pompa a mano • Hand-pump • Pompe manuelle • Handpumpe.

**02** Tubo gomma mt. 1,8 • Fitting hose mt. 1,8 • Tuyau mt. 1,8 • Rohr auf Gummi mt. 1,8.

**03** Pistone con accessori 22/23/24 • Piston with accessories 22/23/24 • Verin avec accessoires 22/23/24 • Zylinder mit Zubehör 22/23/24

**04** Punzone a W a 4 punte • W-punch with 4 points • Poinçon à W à quatre pointes • Prismenaufsatz

**05** Testa elastica grande da avvitare al pistone • Big elastic head to screw on piston • Grande tête caoutchouc à visser au vérin • Große Gummikappe f. Kolben.

**06** Testa elastica piccola da avvitare al pistone • Little elastic head to screw on piston • Petite tête caoutchouc à visser au vérin • Kleine Gummikappe f. Kolben.

**07** Punzone a cuneo • Wedge-shaped punch • Poinçon à coin • Keilaufsatz.

**08** Piastra concava • Concave plate • Plaque concave • Gebogene Aufsatzdruckplatte.

**09** Niplo da applicare al cilindro • Nipple to fit to cylinder • Nipple à appliquer au cylindre • Zylinderzwischenstück

**10** Pinza per apertura, capacità 1 Ton • Pliers to open mudguards, capacity 1 Ton. • Main écarteuse, capacité 1 Ton. • Kotflügelspreizer, Kapazität 1 Ton.

**11** Base d'appoggio da applicare al pistone • Supporting base to fit to piston • Plaque d'extension à appliquer au vérin • Basisplatte am Kolben anzubringen.

**12** Piastra di estensione da applicare al pistone • Extension plate to fit to piston • Plaque d'extension à appliquer au vérin • Druckplatte, am Kolben anzubringen.

**13** Piastra di estensione da applicare al cilindro • Extension plate to fit to cylinder • Plaque d'extension à appliquer au cylindre • Druckplatte, am Zylinder anzubringen.

**14** N. 3 raccordi per prolunghe • N. 3 extension pipe fittings • N. 3 raccords pour rallonges • N. 3 Verlängerungsmuffen.

**15** Tubo prolunga lunghezza 200 mm. • 200 mm. extension pipe • Rallonge 200 mm. • Verlängerungsrohr 200 mm.

**16** Tubo prolunga lunghezza 300 mm. • 300 mm. extension pipe • Rallonge 300 mm. • Verlängerungsrohr 300 mm.

**17** Tubo prolunga lunghezza 400 mm. • 400 mm. extension pipe • Rallonge 400 mm. • Verlängerungsrohr 400 mm.

**18** Tubo prolunga lunghezza 500 mm. • 500 mm. extension pipe • Rallonge 500 mm. • Verlängerungsrohr 500 mm.

**19** Piastra per catene da applicare al cilindro dalla parte del pistone • Plate for chains to fit to cylinder at the piston side • Plaque pour chaînes à appliquer au cylindre du côté du vérin • Spannplatte mit 2 Ketten kolbenseitig am Zylinder anzubringen.

**20** N. 2 piastre per trazione e avvicinamento • N. 2 traction and approach plates • N. 2 plaques pour traction et approche • N. 2 Stk. Zug + Druckplatten.

**21** N. 2 catene • N. 2 chains • N. 2 chaînes • N. 2 Ketten.

**22** Tappo terminale da applicare al pistone • Terminal cap to fit to piston • Bouchon terminal à appliquer au vérin • Verschlusskappe f. Kolben.

**23** Tappo terminale da applicare al cilindro • Terminal cap to fit to cylinder • Bouchon d'embout de verin • Verschlusskappe f. Zylinder.

**24** Anello protezione filetto cilindro • Protection ring of cylinder thread • Bague de protection du filet du cylindre • Schutzring für Zylindergewinde.

**12  
TON**



**ART. 101**



**ART. 102**

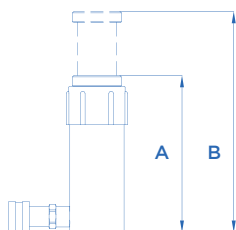

ART.	A mm	B mm
<b>101</b>	320	480
<b>102</b>	320	480
<b>102 EXPORT</b>	320	480



**ART. 102/EXPORT**

**ACCESSORI EXTRA DOTAZIONE**

EXTRA EQUIPMENT • ACCESSOIRES EN OPTION • EXTRA ZUBEHÖR



**ART. CM  
CASSETTA IN METALLO**

Metal box • Boîte en métal  
• Blechkiste



**ART. CPT  
CARRELLO A DUE PIANI**

Two-shelf trolley • Chariot à deux étage  
• Wagen mit zwei Ablageflächen

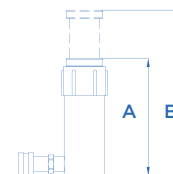

**ART. 108  
PISTONE CORTO**

Short piston • Vérin court  
• Kleiner Zylinder

TON	A mm	B mm
12	150	230

**ART. 357  
POMPA IDROPNEUMATICA  
COMPLETA DI TUBO IN GOMMA  
CON ATTACCO RAPIDO**

Pneumohydraulic pump complete with rapid fitting hose  
Pompe hydropneumatique avec tuyau raccord rapide  
Pneumohydraulische Pumpe mit Anschlußschlauch mit Schnellkupplung



**5  
TON**

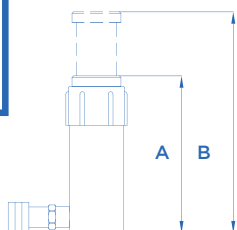

**ART.**

**105**

**A**  
mm

265

**B**  
mm

380



**ART. 105**

### ACCESSORI EXTRA DOTAZIONE

EXTRA EQUIPMENT • ACCESSOIRES EN OPTION • EXTRA ZUBEHÖR

#### ART. CPT CARRELLO A DUE PIANI

Two-shelf trolley • Chariot à deux étage  
Wagen mit zwei Ablageflächen



#### ART. 357 POMPA IDROPNEUMATICA COMPLETA DI TUBO IN GOMMA CON ATTACCO RAPIDO

Pneumohydraulic pump complete with rapid fitting hose  
Pompe hydropneumatique avec tuyau raccord rapide  
Pneumohydraulische Pumpe mit Anschlußschlauch mit Schnellkupplung



#### ART. 290 ALLARGATORE IDRAULICO A CUNEO COMPLETO DI ACCOPIATORE RAPIDO APERTURA 85 MM. DA 1 TON

1 Ton. hydraulic wedge spread, opening 85 mm.  
Ouverture hydraulique à coin de max. 85 mm. Puissance 1 Ton. équipée d'un demi-coupleur rapide.  
Hydraulischer Spreizer. Öffnung max. 85 mm. ausgestattet mit Schnellöffnung. Zugkraft 1 Ton.

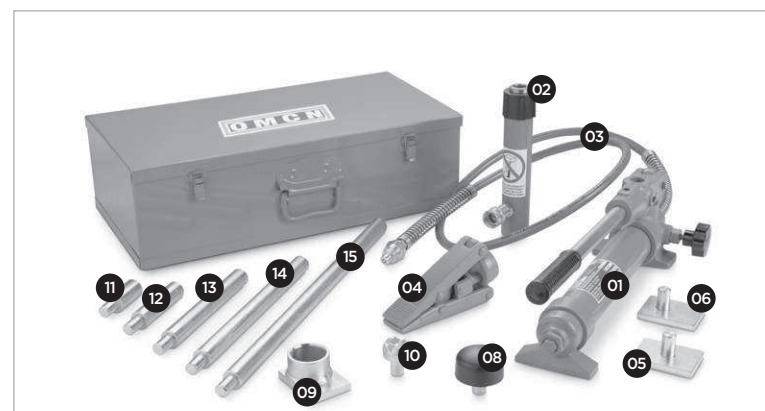

- 01** Pompa • Pump • Pompe • Pumpe.
- 02** Pistone • Piston • Verin • Zylinder.
- 03** Tubo gomma mt. 1,8 • Fitting hose mt. 1,8 • Tuyau mt. 1,8 • Rohr auf Gummi mt. 1,8.
- 04** Pinza apertura parafanghi, capacità 1 Ton. • Pliers to open mudguards, capacity 1 Ton. • Pince ouverture pare-boues, capacité 1 Ton. • Kotflügelspreizer, Kapazität 1 Ton.
- 04/A** Pinza apertura parafanghi, capacità 1 Ton. • Pliers to open mudguards, capacity 1 Ton. Pince ouverture pare-boues, capacité 1 Ton. • Kotflügelspreizer, Kapazität 1 Ton.
- 05** Base d'appoggio • Supporting base • Base d'appui • Stützplatte.
- 06** Piastra di estensione da applicare al pistone • Extension plate to fit to the piston • Plaque d'extension à appliquer au vérin • Zugplatte, wird am Kolben angebracht.
- 08** Testa elastica • Elastic head • Tête caoutchouc • Prismenaufsatz.
- 09** Piastra di estensione da applicare al cilindro • Extension plate to fit to the cylinder • Plaque d'extension à joindre au cylindre • Keilaufsatz, wird am Kolben angebracht.
- 10** Punzone a W • W punch • Poinçon à W • Zugplatte, wird am Zylinder angebracht.
- 11** Tubo prolunga 50 mm. • 50 mm. extension pipe • Rallonge 50 mm. • Verlängerungsrohr 50 mm.
- 12** Tubo prolunga 100 mm. • 100 mm. extension pipe • Rallonge 100 mm. • Verlängerungsrohr 100 mm.
- 13** Tubo prolunga 200 mm. • 200 mm. extension pipe • Rallonge 200 mm. • Verlängerungsrohr 200 mm.
- 14** Tubo prolunga 300 mm. • 300 mm. extension pipe • Rallonge 300 mm. • Verlängerungsrohr 300 mm.
- 14/A** Tubo prolunga 400 mm. • 400 mm. extension pipe • Rallonge 400 mm. • Verlängerungsrohr 400 mm.
- 15** Tubo prolunga 500 mm. • 500 mm. extension pipe • Rallonge 500 mm. • Verlängerungsrohr 500 mm.
- 16/A** Raccordi per prolunghe • Extension pipe fittings • Raccords pour rallonges • Zubehörteile für Verlängerungsrohre.

**12  
TON**

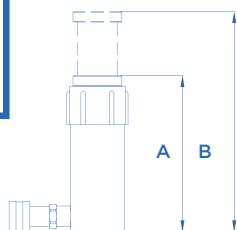

**ART.**

**353**

**A**  
mm

360

**B**  
mm

520



**ART. 353**

**ACCESSORI EXTRA DOTAZIONE**

EXTRA EQUIPMENT • ACCESSOIRES EN OPTION • EXTRA ZUBEHÖR

**ART. CPT  
CARRELLO  
A DUE PIANI**

Two-shelf trolley  
Chariot à deux étage  
Wagen mit zwei  
Ablageflächen



**ART. 357  
POMPA IDROPNEUMATICA COMPLETA DI  
TUBO IN GOMMA CON ATTACCO RAPIDO**

Pneumohydraulic pump complete with rapid fitting hose  
Pompe hydropneumatique avec tuyau raccord rapide  
Pneumohydraulische Pumpe mit  
Anschlußschlauch mit Schnellkupplung



**ART. 108  
PISTONE CORTO**

Short piston  
Vérin court  
Kleiner Zylinder



**TON**

12

**A**  
mm

150

**B**  
mm

230

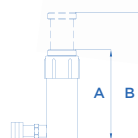

**ART. 290  
ALLARGATORE IDRAULICO A CUNEO COMPLETO DI  
ACCOPPIATORE RAPIDO APERTURA 85 MM. DA 1 TON**

1 Ton. hydraulic wedge spread, opening 85 mm.  
Ouverture hydraulique à coin de max. 85 mm. Puissance 1 Ton. équipée  
d'un demi-coupleur rapide.  
Hydraulischer Spreizer. Öffnung max. 85 mm. ausgestattet mit Schnellöffnung. Zugkraft 1 Ton.



- 01 Pompa • Pump • Pompe • Pumpe.
- 02 Pistone • Piston • Verin • Zylinder.
- 03 Tubo gomma mt. 1,8 • Fitting hose mt. 1,8 • Tuyau mt. 1,8 • Rohr auf Gummi mt. 1,8.
- 04 Cassetta metallica • Metal box • Coffret métallique • Rückschlagventil und Blechkiste.
- 06 Base d'appoggio • Supporting base • Base d'appui • Stützplatte.
- 07 Piastra di estensione da applicare al pistone • Extension plate to fit to the piston  
• Plaque d'extension à appliquer au vérin • Zugplatte, wird am Kolben angebracht.
- 08 Piastra di estensione da applicare al cilindro • Extension plate to fit to the cylinder  
• Plaque d'extension à joindre au cylindre • Keilaufsatz, wird am Kolben angebracht.
- 09 Punzone a W • W punch • Poinçon à W • Zugplatte, wird am Zylinder angebracht.
- 10 Punzone zigrinato • Knurled punch • Poinçon moleté • Gerändeltes Stempelplatte.
- 11 Punzone a cuneo • Wedge-shaped punch • Poinçon à coin • Keilaufsatz.
- 12 Testa elastica • Elastic head • Tête caoutchouc • Prismenaufsatz.
- 13 Raccordo doppio maschio • Double male fitting • Raccord double mâle • Adapter.
- 14 Tubo prolunga 120 mm. • 120 mm. extension pipe • Rallonge 120 mm.  
• Verlängerungsrohr 120 mm.
- 15 Tubo prolunga 250 mm. • 250 mm. extension pipe - Rallonge 250 mm.  
• Verlängerungsrohr 250 mm.
- 16 Tubo prolunga 460 mm. • 460 mm. extension pipe • Rallonge 460 mm.  
• Verlängerungsrohr 460 mm.
- 17 Tubo prolunga 630 mm. • 630 mm. extension pipe • Rallonge 630 mm.  
• Verlängerungsrohr 630 mm.

**6  
TON**

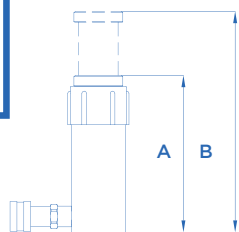

<b>ART.</b> <b>355</b>	<b>A</b> mm 290	<b>B</b> mm 410
---------------------------	-----------------------	-----------------------



**ART. 355**



**ACCESSORI EXTRA DOTAZIONE**

EXTRA EQUIPMENT • ACCESSOIRES EN OPTION • EXTRA ZUBEHÖR

**ART. CPT  
CARRELLO  
A DUE PIANI**

Two-shelf trolley  
Chariot à deux étages  
Wagen mit zwei  
Ablageflächen



**ART. 357  
POMPA IDROPNEUMATICA COMPLETA DI  
TUBO IN GOMMA CON ATTACCO RAPIDO**

Pneumohydraulic pump complete with rapid fitting hose  
Pompe hydro-pneumatique avec tuyau raccord rapide  
Pneumohydraulische Pumpe mit  
Anschlußschlauch mit Schnellkupplung



**ART. 108/A  
PISTONE CORTO**

Short piston  
Vérin court  
Kleiner Zylinder



<b>TON</b> 6	<b>A</b> mm 150	<b>B</b> mm 230
-----------------	-----------------------	-----------------------

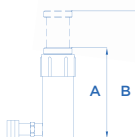

**ART. 290  
ALLARGATORE IDRAULICO A CUNEO COMPLETO DI  
ACCOPPIATORE RAPIDO APERTURA 85 MM. DA 1 TON**

1 Ton. hydraulic wedge spread, opening 85 mm.  
Ouverture hydraulique à coin de max. 85 mm. Puissance 1 Ton. équipée  
d'un demi-coupleur rapide.  
Hydraulischer Spreizer. Öffnung max. 85 mm. ausgestattet mit Schnellöffnung. Zugkraft 1 Ton.



- 01 Pompa • Pump • Pompe • Pumpe.
- 02 Pistone • Piston • Verin • Zylinder.
- 03 Tubo gomma mt. 1,8 • Fitting hose mt. 1,8 • Tuyau mt. 1,8 • Rohr auf Gummi mt. 1,8.
- 04 Cassetta metallica • Metal box • Coffret métallique • Rückschlagventil und Blechkiste.
- 06 Piastra di estensione da applicare al cilindro • Extension plate to fit to the cylinder  
• Plaque d'extension à joindre au cylindre • Keilaufsatz, wird am Kolben angebracht.
- 07 Base d'appoggio • Supporting base • Base d'appui • Stützplatte.
- 08 Raccordo doppio maschio • Double male fitting • Raccord double mâle • Adapter.
- 09 Punzone zigrinato • Knurled punch • Poinçon moleté • Gerändelte Stempelplatte.
- 10 Punzone a W • W punch • Poinçon à W • Zugplatte, wird am Zylinder angebracht.
- 11 Punzone a cuneo • Wedge-shaped punch • Poinçon à coin • Gummikappe.
- 12 Piastra di estensione da applicare al pistone • Extension plate to fit to the piston  
• Plaque d'extension à appliquer au vérin • Zugplatte, wird am Kolben angebracht.
- 13 Testa elastica • Elastic head • Tête caoutchouc • Prismenaufsatz.
- 14 Tubo prolunga 75 mm. • 75 mm. extension pipe • Rallonge 75 mm.  
• Verlängerungsrohr 75 mm.
- 15 Tubo prolunga 150 mm. • 150 mm. extension pipe • Rallonge 150 mm.  
• Verlängerungsrohr 150 mm.
- 16 Tubo prolunga 250 mm. • 250 mm. extension pipe • Rallonge 250 mm.  
• Verlängerungsrohr 250 mm.
- 17 Tubo prolunga 400 mm. • 400 mm. extension pipe • Rallonge 400 mm.  
• Verlängerungsrohr 400 mm.
- 18 Tubo prolunga 500 mm. • 500 mm. extension pipe • Rallonge 500 mm.  
• Verlängerungsrohr 500 mm.



ART. 100

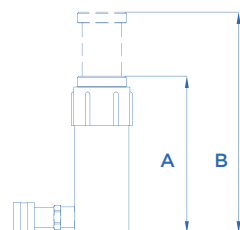

ART.	TON	A mm	B mm
100	20	310	440
100/A	30	310	440



ART. 100/C

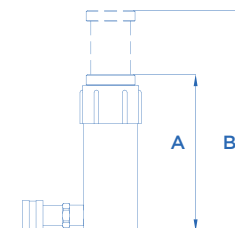

ART.	TON	A mm	B mm
100/B	50	330	465
100/C	80	340	480
100/D	120	320	460

**ART. 100 • 100/A • 100/B • 100/C • 100/D**

**01** Pompa • Pump • Pompe • Pumpe.

**02** Tubo gomma mt. 1,8 • Fitting hose mt. 1,8 • Tuyau mt. 1,8 • Rohr auf Gummi mt. 1,8.

**03** Pistone • Piston • Verin • Zylinder.

**04** Tubo prolunga 100 mm. • 100 mm. extension pipe • Rallonge 100 mm. • Verlängerungsrohr 100 mm.

**05** Tubo prolunga 200 mm. • 200 mm. extension pipe • Rallonge 200 mm. • Verlängerungsrohr 200 mm.

**06** Tubo prolunga 300 mm. • 300 mm. extension pipe • Rallonge 300 mm. • Verlängerungsrohr 300 mm.

**07** Tubo prolunga 400 mm. • 400 mm. extension pipe • Rallonge 400 mm. • Verlängerungsrohr 400 mm.

**08** Tubo prolunga 500 mm. • 500 mm. extension pipe • Rallonge 500 mm. • Verlängerungsrohr 500 mm.

**09** Raccordi per prolungha • Extension pipe fittings • Raccords pour rallonges • Zubehörteile für Verlängerungsrohre.

**10** Tappi terminali • Terminal caps • Bouchons terminaux • Verschlusskappen.







**ART. 350/A**  
**POMPA IDRAULICA MANUALE COMPLETA DI TUBO**  
**IN GOMMA CON ATTACCO RAPIDO**

Hydraulic pump complete with rapid fitting hose  
 Pompe hydraulique avec tuyau à raccord rapide  
 Hydraulische Pumpe mit Anschlußschlauch mit Schnellkupplung



**ART. 357**  
**POMPA IDROPNEUMATICA COMPLETA DI TUBO**  
**IN GOMMA CON ATTACCO RAPIDO**

Pneumohydraulic pump complete with rapid fitting hose  
 Pompe hydro-pneumatique avec tuyau raccord rapide  
 Pneumohydraulische Pumpe mit Anschlußschlauch mit Schnellkupplung

**PISTONI SPINGENTI**

PUSHING CYLINDERS  
 VÉRINS POUSSEURS  
 DRUCKZYLINDERN

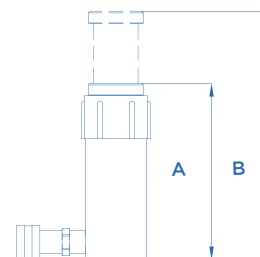

ART.	TON	A mm	B mm
108	12	150	230
108/A	6	150	230
350/C	12	400	630

**ART. 108**  
**PISTONE**  
**CORTO**

Short piston  
 Vérin court  
 Kleiner Zylinder

12  
TON



**ART. 108/A**  
**PISTONE**  
**CORTO**

Short piston  
 Vérin court  
 Kleiner Zylinder

6  
TON



**ART. 350/C**

12  
TON



OPTIONAL



=



**ART. 324**  
**ATTACCO SPECIALE**  
**PER BANCHI**  
**DI SQUADRATURA**

Special swivel attachment  
 Attache spéciale pour marbres de redressement  
 Verbindungsgabel für Richtbänke

## PISTONI TIRANTI

PULLING CYLINDERS  
VÉRINS TIREURS  
ZUGZYLINDER



6  
TON

ART. 350/D



6  
TON

ART. 351

ART.	TON	A <sub>mm</sub>	B <sub>mm</sub>
350/D	6	530	350
351	6	770	470

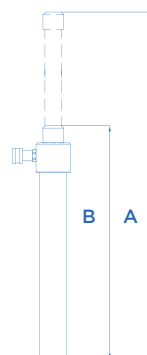

### OPTIONAL

#### ART. 321 GANCIO A DOPPIA PRESA (MANINA) CON ATTACCO FILETTATO

Claw hook with threaded connection.

Crochet à double prise articulé sur raccord fileté femelle.

Klaue mit Gewinde.



### OPTIONAL

#### ART. 322 OCCHIELLO PER AGGANCIAMENTO CATENA AL PISTONE

Hook for joining closed chain to power ram.

Oeillet pour attache rapide de chaîne.

Öse zum Anhängen der Kette an den Kolben.



### OPTIONAL

#### ART. 350/E

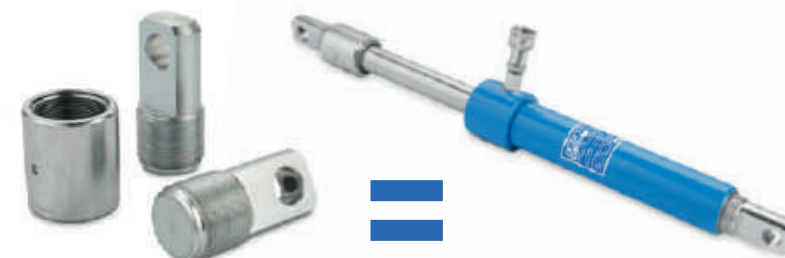

**KIT**

**ART. 106/A  
PISTONE TIRANTE**

Pulling piston.  
Vérin tirant.  
Zugzylinder.

**6  
TON**



Completo di attacco rapido, n° 2 raccordi filettati con naselli snodati, n° 2 catene da mt. 1,5 complete di gancio.

Complete with rapid coupling, no 2 threaded couplings with jointed nips and 2 1,5 mt. chains complete with hook.

Avec raccord rapide, 2 raccords filetés avec déclics dénoués et 2 chaînes de 1,5 mt. avec crochet.

Komplett mit Schnellkupplung, 2 Kupplungen mit Gewinde und 2 1,5 mt. langen Ketten mit Haken.

ART.	TON	A mm	B mm
106/A	6	610	395
106/B	4	460	310

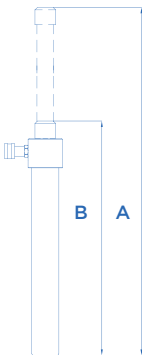

**KIT**

**ART. 106/B  
PISTONE TIRANTE**

**4  
TON**

Pulling piston.  
Vérin tirant.  
Zugzylinder.



Completo di attacco rapido e di due supporti con gancio nelle parti terminali.

Complete with rapid coupling and with two supports equipped with hook in terminal parts.

Livré avec raccord rapide et 2 supports avec crochets aux extrémités.

Komplett mit Schnellkupplung und 2 Gewindekupplungen mit Haken.



**OPTIONAL**

**ART. 106/B1**



N° 2 catene filo Ø 7 in acciaio legato ad elevata resistenza, bonificate, collaudate e cromate, da mt. 1,5 cad. complete di gancio.

No. 2 chains wire Ø 7 in high resistance alloy steel, tempered, tested and chromated of mt. 1,5 each one, complete with hook.

2 chaînes fil Ø 7 en acier trempé et chromé. Longueur 1,5 mt. chacune avec crochet.

2 Ketten Ø 7 aus einer hochwiderstandsfähigen Stahllegierung; gehärtet, geprüft und verchromt, 1,5 mt. lang, komplett mit Haken.

**ART. 096  
BATTITOIO A CONTRACCOLPO**

Counterblow hammer.  
Appareil pour le coup et contrecoup.  
Schlaghammer.



**ART. 096/A  
BATTITOIO A CONTRACCOLPO CORREDATO DI GANCI SPECIALI ED INNESTO PER MORSETTI**

Counterblow hammer with special hooks and coupling for clamps.  
Appareil pour le coup et contrecoup avec crochets spéciaux et greffe pour étaux.  
Schlaghammer ausgestattet mit Spezialhaken und Klemmenaufnahme



**ART. 290  
ALLARGATORE IDRAULICO A CUNEO COMPLETO DI ACCOPIATORE RAPIDO APERTURA 85 MM. DA 1 TON**

1 Ton. hydraulic wedge spread, opening 85 mm.  
Ouverture hydraulique à coin de max. 85 mm. Puissance 1 Ton. équipée d'un demi-coupleur rapide.  
Hydraulischer Spreizer. Öffnung max. 85 mm. ausgestattet mit Schnellöffnung. Zugkraft 1 Ton.

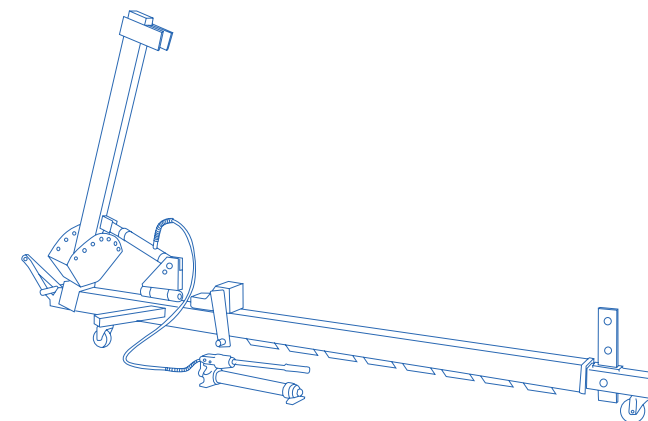

## **RADDRIZZATORI PER CARROZZERIA**

STRAIGHTENERS FOR CAR-BODY SHOP  
EQUERRES DE REDRESSAGE POUR CARROSSERIE  
KAROSSERIE-RICHTGERÄTE

Made in Italy 

**8  
TON** **STRONG  
LINE**

# RADDRIZZATORI PER CARROZZERIA

STRAIGHTENERS FOR CAR-BODY SHOP

EQUERRES DE REDRESSAGE POUR CARROSSERIE

KAROSSERIE-RICHTGERÄTE



con braccio verticale rotante  
with vertical rotary arm  
avec bras vertical tournant  
mit seitlich schwenkbarem Vertikalarm



ART. STRONG MAJOR/R

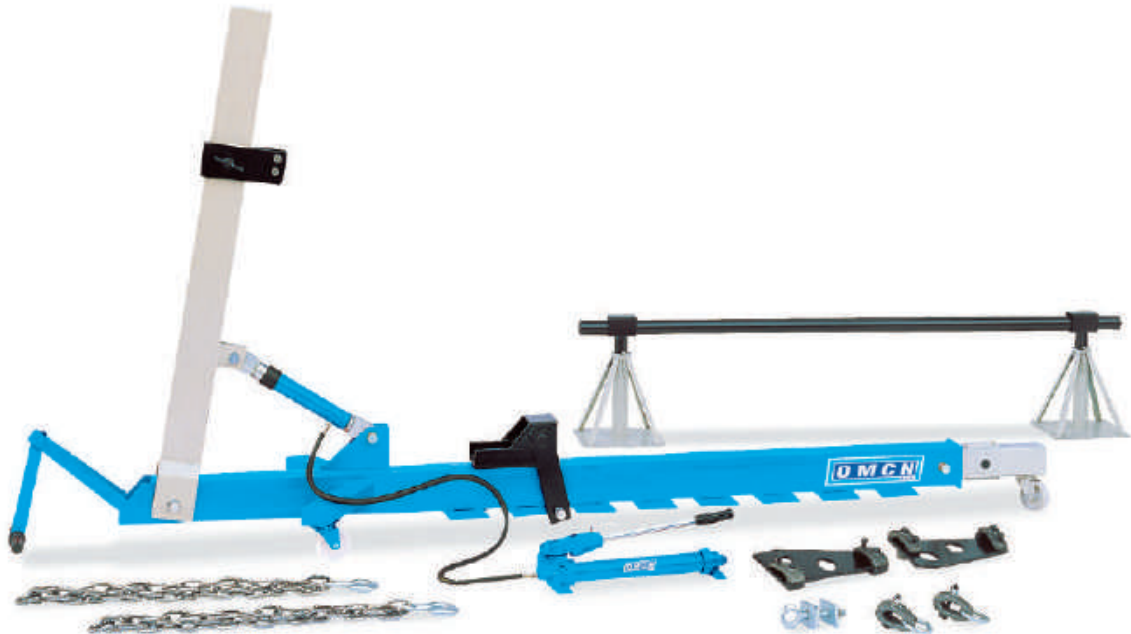

ART. STRONG EXPORT

ART.	MAX mm	MIN mm	mm	KG
MAJOR/R	6500	3650	1750	340
EXPORT	4600	3150	1650	250

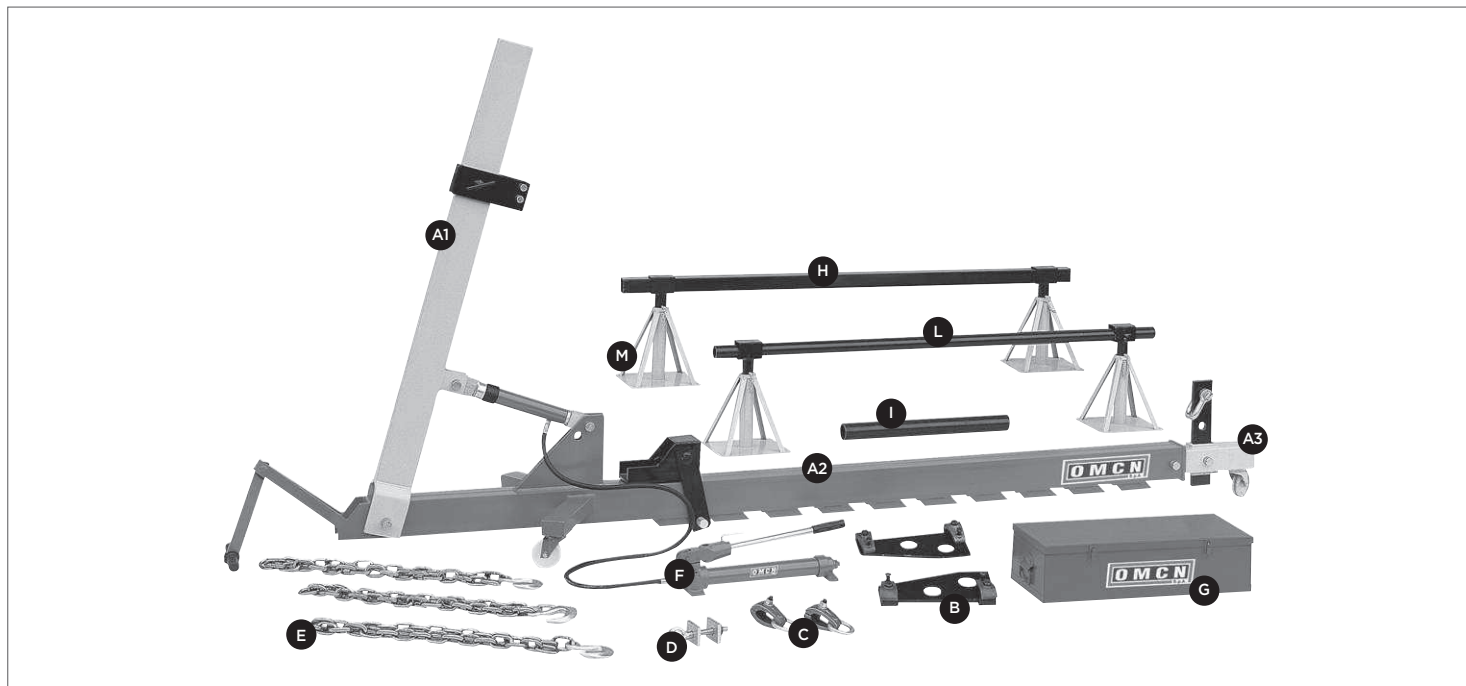

**A/1** Braccio verticale sul quale scorre il morsetto di agganciamento catene • Vertical arm • Bras vertical • Vertikalarm, auf dem die Kettenklemme läuft.

**A/2** Braccio orizzontale sul quale scorre la staffa di ancoraggio a due posizioni alta e bassa con il sistema di bloccaggio • Horizontal arm • Bras horizontal  
• Horizontalarm, auf dem der Verankerungssattel mit Hoch und Tiefeinstellung und (patentiertem) Fixiersystem läuft.

**A/3** Braccio di prolunga alla cui estremità si inserisce il piatto attacco catene • Extension arm • Bras d'extension  
• Verlängerungsarm, an dessen Ende der Kettenteller eingesetzt wird.

**B** Piastre a morsetti speciali • Special clamp plates • Plaques à étaux spéciaux • Platten mit Spezialklemmen

**C** Morsetti autobloccanti • Self-locking clamps, specially designed to hook the damaged part  
• Etaux auto-bloquants • Selbstschließende Klemmen, um die beschädigten Teile einzuhaken

**D** Tirante con doppia piastra • Tie bar with double plate • Tirant avec plaque double • Doppelplattenzuganker

**E** Catene con ganci • Chains with hook • Chaînes avec croche • Ketten mit Haken

**F** Pompa idraulica con tubo flessibile e pistone • Hydraulic pump + piston + hose • Pompe hydraulique + vérin + tube flexible • Blechkasten

**G** Cassetta in lamiera • Sheet box • Caisse en tôle • Vierkantröhr

**H** Barra quadra • Square bar • Barre carrée • Vierkantröhr

**I** Barra tonda • Round bar • Barre ronde • Rundrohr

**L** Barra tonda corta • Short round bar • Barre ronde courte • Kurzes Rundrohr

**M** Colonnate sostegno vettura • Car supporting stands • Chandelles d'appui pour voitures • Unterstellböcke





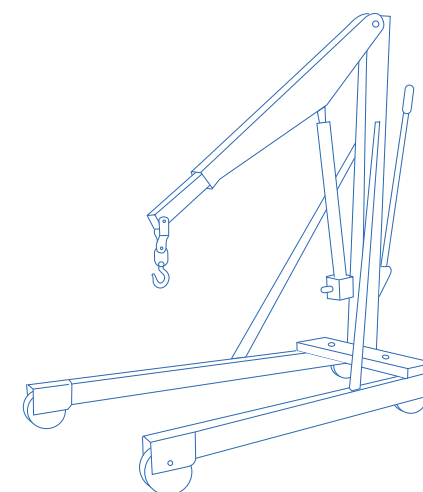

**GRU IDRAULICHE  
A CARRELLO**

TROLLEY HYDRAULIC CRANES  
GRUES HYDRAULIQUES A CHARIOT  
FAHRBARE HYDRAULIKKRÄNE

Made in Italy 





**ART. 134**

### TRACCIATO TECNICO COSTRUTTIVO

- Lo stelo rettificato e cromato garantisce un'alta affidabilità nel tempo.
- Braccio allungabile in quattro posizioni di lavoro.
- Ruote posteriori girevoli per la massima manovrabilità.
- Gancio girevole a 360°.
- Dotata di tiranti laterali.
- Valvola di protezione contro i sovraccarichi incorporata.
- Comando di discesa a velocità controllata.
- Pompa idraulica ad una velocità (131 - 132).
- Pompa idraulica a due velocità (133 - 134).
- Dotata di ruote in gomma (131 - 133).
- Dotata di ruote in gomma e nylon (132 - 134).

### TECHNICAL AND STRUCTURAL LAY-OUT

- Ground chrome-plated rod for top reliability over time.
- Extendable arm in 4 working positions.
- Revolving rear wheels to move it easily.
- 360° revolving hook.
- Lateral tie-rods.
- Safety valve to avoid any possible overload.
- Descent control device with a controlled speed.
- One speed hydraulic pump (131 - 132).
- Two speed hydraulic pump (133 - 134).
- Rubber wheels (131 - 133).
- Rubber and nylon wheels (132 - 134).





### RELEVÉ TECHNIQUE

- Vérin en acier spécial, rectifié et chromé, robuste et résistant.
- Flèche extensible: 4 positions de travail possibles.
- Roues arrière pivotantes pour faciliter les déplacements.
- Crochet pivotant à 360°.
- Tirants latéraux.
- Soupape de sécurité anti-surchage.
- Commande de descente à vitesse contrôlée.
- Pompe hydraulique à une vitesse (131 - 132).
- Pompe hydraulique à deux vitesses (133 - 134).
- Roues en caoutchouc (131 - 133).
- Roues en caoutchouc et nylon (132 - 134).

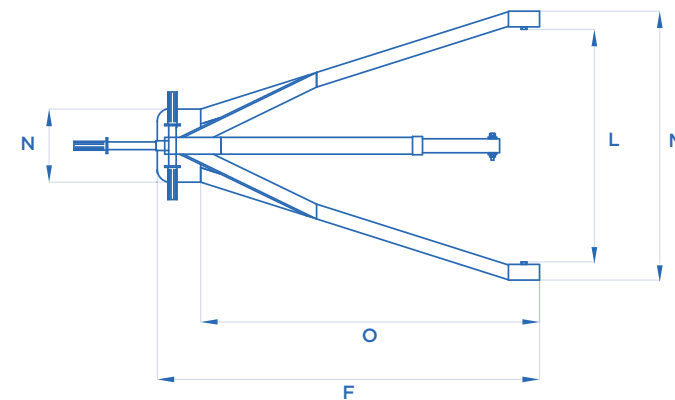
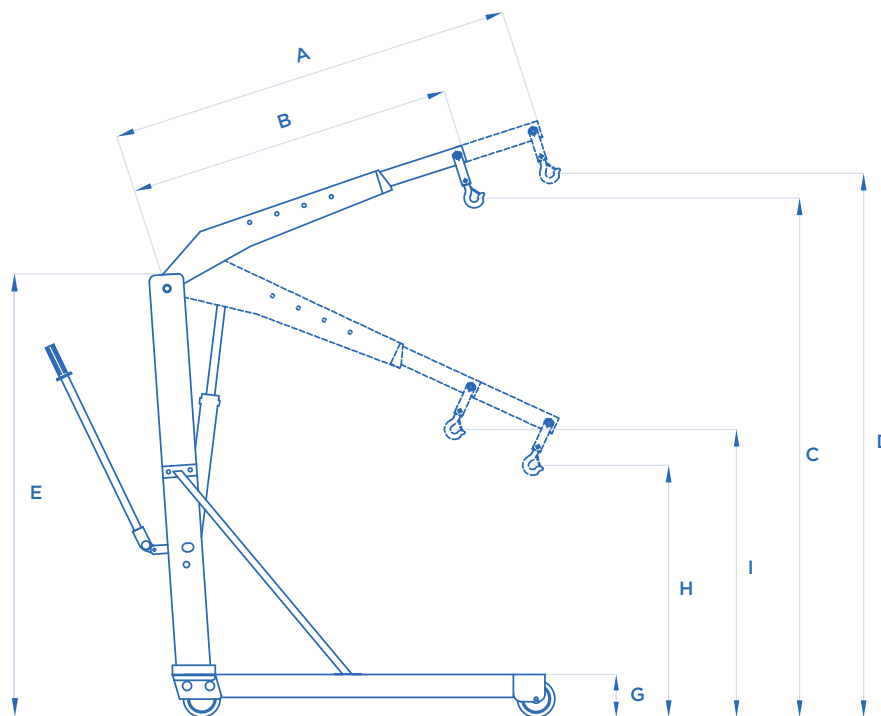
### TECHNISCHE UND KONSTRUKTIVE ANGABEN

- Verchromte und schleifende Kolben, der eine große Zuverlässigkeit im Laufe der Zeit garantiert.
- Ausziehbarer Arm in vier Arbeitspositionen.
- Mit drehbaren Hinterrädern, um die maximale Wendigkeit zu sichern.
- 360° drehbare Haken.
- Mit seitlichen Zugöse.
- Angebaut Überlastventil gegen jeder Überlastung.
- Abstiegskontrolle mit einer kontrollierten Geschwindigkeit.
- Einstufige hydraulische Pumpe (131 - 132).
- Zweistufige hydraulische Pumpe (133 - 134).
- Mit Gummirädern (131 - 133).
- Mit Gummi- und Nylonrädern (132 - 134).



ART.				
<b>131 • 133</b>	500 kg	400 kg	250 kg	150 kg
<b>132 • 134</b>	1000 Kg	800 Kg	500 Kg	300 Kg



ART.		A mm	B mm	C mm	D mm	E mm	F mm	G mm	H mm	I mm	L mm	M mm	N mm	O mm	
<b>131</b>	500 Kg	1315	1015	2130	2355	1560	1295	160	435	660	785	900	600	1140	75
<b>132</b>	1000 Kg	1540	1250	2390	2670	1720	1530	180	470	670	955	1075	745	1360	110
<b>133</b>	500 Kg	1315	1015	2130	2355	1560	1295	160	435	660	785	900	600	1140	75
<b>134</b>	1000 Kg	1540	1250	2390	2670	1720	1530	180	470	670	955	1075	745	1360	110



#### TRACCIATO TECNICO COSTRUTTIVO

- Lo stelo rettificato e cromato garantisce un'alta affidabilità nel tempo.
- Braccio allungabile in quattro posizioni di lavoro.
- Ruote posteriori girevoli per la massima manovrabilità.
- Gancio girevole a 360°.
- Dotata di tiranti laterali.
- Valvola di protezione contro i sovraccarichi incorporata.
- Comando di discesa a velocità controllata.
- Pompa idraulica a due velocità.
- Dotata di ruote in poliuretano.

#### TECHNICAL AND STRUCTURAL LAY-OUT

- Ground chrome-plated rod for top reliability over time.
- Extendable arm in 4 working positions.
- Revolving rear wheels to move it easily.
- 360° revolving hook.
- Lateral tie-rods.
- Safety valve to avoid any possible overload.
- Descent control device with a controlled speed.
- Two-speed hydraulic pump.
- Polyurethane wheels.





#### RELEVÉ TECHNIQUE

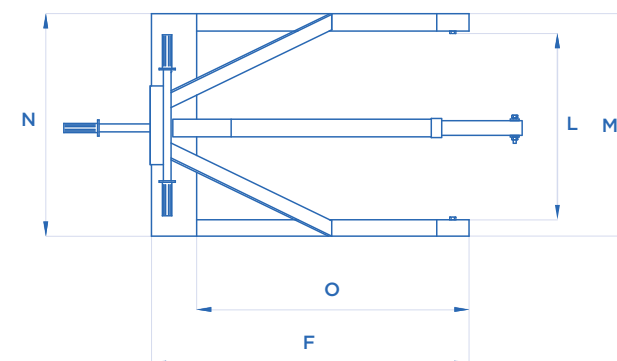
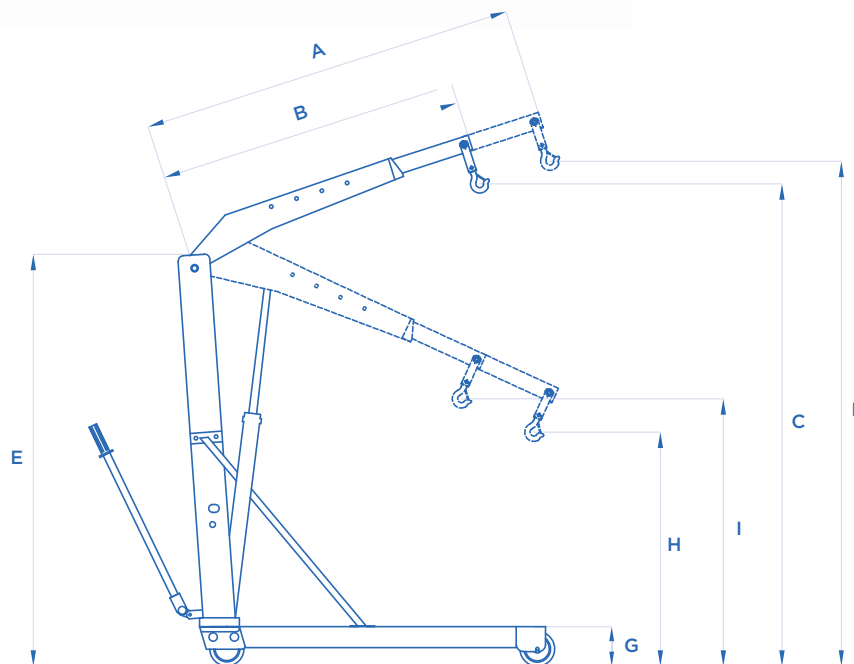

- Vérin en acier spécial, rectifié et chromé, robuste et résistant.
- Flèche extensible: 4 positions de travail possibles.
- Roues arrière pivotantes pour faciliter les déplacements.
- Crochet pivotant à 360°.
- Tirants latéraux.
- Commande de descente à vitesse contrôlée.
- Pompe hydraulique à deux vitesses.
- Roues en polyuréthane.

#### TECHNISCHE UND KONSTRUKTIVE ANGABEN

- Verchromte und schleifende Kolben, der eine große Zuverlässigkeit im Laufe der Zeit garantiert.
- Ausziehbarer Arm in vier Arbeitspositionen.
- Mit drehbaren Hinterrädern, um die maximale Wendigkeit zu sichern.
- 360° drehbare Haken.
- Mit seitlichen Zugöse.
- Angebaut Überlastventil gegen jeder Überlastung.
- Abstiegskontrolle mit einer kontrollierten Geschwindigkeit.
- Zweistufige hydraulische Pumpe.
- Mit Polyurethanrädern.



ART.				
<b>SL/15</b>	1500 kg	1200 kg	800 kg	500 kg
<b>SL/20</b>	2000 Kg	1500 Kg	1000 Kg	600 Kg
<b>SL/30</b>	3000 Kg	2400 Kg	1850 Kg	1300 Kg

ART.		A  mm	B  mm	C  mm	D  mm	E  mm	F  mm	G  mm	H  mm	I  mm	L  mm	M  mm	N  mm	O  mm	 KG
<b>SL/15</b>	1500 Kg	1815	1370	2470	2750	1865	1690	195	310	630	830	1015	1000	1450	190
<b>SL/20</b>	2000 Kg	1910	1460	2780	3110	1990	1910	215	315	645	940	1120	1100	1640	235
<b>SL/30</b>	3000 Kg	2280	1790	3300	3730	2150	2270	265	510	780	1170	1420	1400	1910	480



ART. 138

#### TRACCIATO TECNICO COSTRUTTIVO

- Lo stelo rettificato e cromato garantisce un'alta affidabilità nel tempo.
- Braccio allungabile in quattro posizioni di lavoro.
- Ruote posteriori girevoli per la massima manovrabilità.
- Gancio girevole a 360°.
- Valvola di protezione contro i sovraccarichi incorporata.
- Comando di discesa a velocità controllata.
- Pompa idraulica a due velocità.
- Dotata di ruote in gomma (135).
- Dotata di ruote in gomma e poliuretano (136).
- Dotata di ruote in poliuretano (137 - 138 - 138/A).

#### TECHNICAL AND STRUCTURAL LAY-OUT

- Ground chrome-plated rod for top reliability over time.
- Extendable arm in 4 working positions.
- Revolving rear wheels to move it easily.
- 360° revolving hook.
- Safety valve to avoid any possible overload.
- Descent control device with a controlled speed.
- Two speed hydraulic pump.
- Rubber wheels (135).
- Rubber and polyurethane wheels (136).
- Polyurethane wheels (137 - 138 - 138/A).





#### RELEVÉ TECHNIQUE

- Vérin en acier spécial, rectifié et chromé, robuste et résistant.
- Flèche extensible: 4 positions de travail possibles.
- Roues arrière pivotantes pour faciliter les déplacements.
- Crochet pivotant à 360°.
- Soupape de sécurité anti-surcharge.
- Commande de descente à vitesse contrôlée.
- Pompe hydraulique à deux vitesses.
- Roues en caoutchouc (135).
- Roues en caoutchouc et polyuréthane (136).
- Roues en polyuréthane (137 - 138 - 138/A).

#### TECHNISCHE UND KONSTRUKTIVE ANGABEN

- Verchromte und schleifende Kolben, der eine große Zuverlässigkeit im Laufe der Zeit garantiert.
- Ausziehbarer Arm in vier Arbeitspositionen.
- Mit drehbaren Hinterrädern, um die maximale Wendigkeit zu sichern.
- 360° drehbare Haken.
- Angebaut Überlastventil gegen jeder Überlastung.
- Abstiegskontrolle mit einer kontrollierten Geschwindigkeit.
- Zweistufige hydraulische Pumpe.
- Mit Gummirädern (135).
- Mit Gummi und Polyurethanrädern (136).
- Mit Polyurethanrädern (137 - 138 - 138/A).



ART.				
<b>135</b>	500 Kg	400 kg	250 kg	150 kg
<b>136</b>	1000 Kg	800 Kg	500 Kg	300 Kg
<b>137</b>	1500 Kg	1200 Kg	800 Kg	500 Kg
<b>138</b>	2000 Kg	1500 Kg	1000 Kg	600 Kg
<b>138/A</b>	2500 Kg	2000 Kg	1500 Kg	1000 Kg

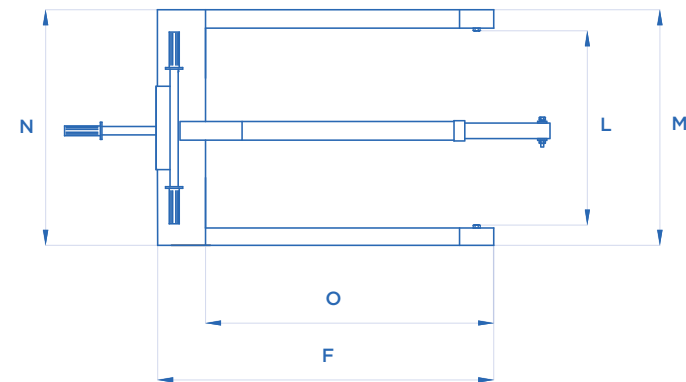
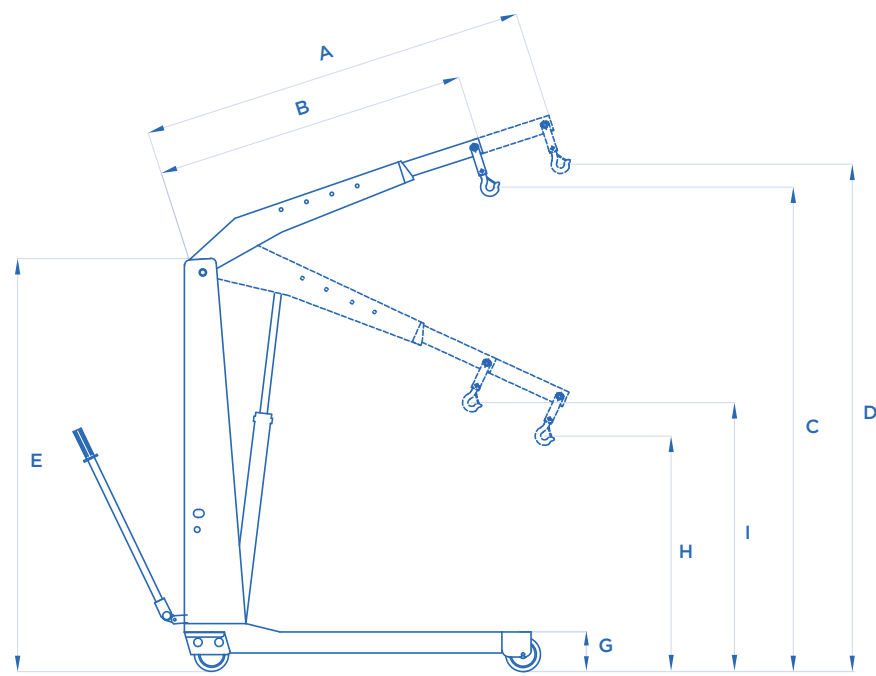

ART.		A mm	B mm	C mm	D mm	E mm	F mm	G mm	H mm	I mm	L mm	M mm	N mm	O mm	
------	---	------	------	------	------	------	------	------	------	------	------	------	------	------	---

<b>135</b>	500 Kg	1315	1010	2260	2490	1700	1370	155	520	745	650	805	800	1075	102
<b>136</b>	1000 Kg	1550	1250	2485	2695	1830	1520	165	560	760	790	960	960	1195	150
<b>137</b>	1500 Kg	1825	1370	2680	3010	1935	1810	185	310	650	960	1145	1140	1415	250
<b>138</b>	2000 Kg	1910	1460	2900	3300	2055	1915	213	510	795	1150	1350	1340	1480	315
<b>138/A</b>	2500 Kg	2010	1565	3020	3390	2085	2085	230	460	760	1180	1405	1390	1610	360



ART. 222

#### TRACCIATO TECNICO COSTRUTTIVO

- Lo stelo rettificato e cromato garantisce un'alta affidabilità nel tempo.
- Braccio allungabile in quattro posizioni di lavoro.
- Timone di manovra posteriore e ruote di grandi dimensioni garantiscono ottima manovrabilità.
- Gancio girevole a 360°.
- Valvola di protezione contro i sovraccarichi incorporata.
- Comando di discesa a velocità controllata.
- Pompa idraulica a due velocità.
- Dotata di ruote in poliuretano.

#### TECHNICAL AND STRUCTURAL LAY-OUT

- Ground chrome-plated rod for top reliability over time.
- Extendable arm in 4 working positions.
- Rear rudder and big wheels to move it easily.
- 360° revolving hook.
- Safety valve to avoid any possible overload.
- Descent control device with a controlled speed.
- Two speed hydraulic pump.
- Polyurethane wheels.

#### RELEVÉ TECHNIQUE

- Vérin en acier spécial, rectifié et chromé, robuste et résistant.
- Flèche extensible : 4 positions de travail possibles.
- Timon placé à l'arrière et roues de grandes dimensions pour faciliter les déplacements.
- Crochet pivotant à 360°.
- Soupape de sécurité anti-surcharge.
- Commande de descente à vitesse contrôlée.
- Pompe hydraulique à deux vitesses.
- Roues en polyuréthane.

#### TECHNISCHE UND KONSTRUKTIVE ANGABEN

- Verchromte und schleifende Kolben, der eine große Zuverlässigkeit im Laufe der Zeit garantiert.
- Ausziehbarer Arm in vier Arbeitspositionen.
- Mit beweglicher Deichsel und großen Rädern, um die maximale Wendigkeit zu sichern.
- 360° drehbare Haken.
- Angebaut Überlastventil gegen jeder Überlastung.
- Abstiegskontrolle mit einer kontrollierten Geschwindigkeit.
- Zweistufige hydraulische Pumpe.
- Mit Polyurethanrädern.

#### ART. 222/A

Supporto a bilanciere intercambiabile con il gancio.

Interchangeable with hook equalizer support.

Support à balancier interchangeable avec le crochet.

Tragschemel mit Ketten.

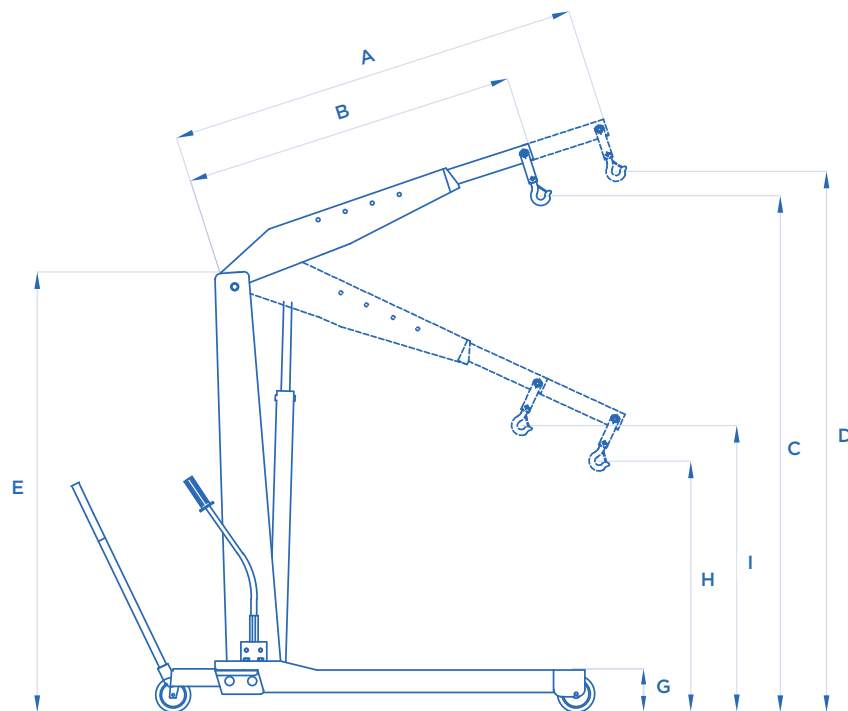
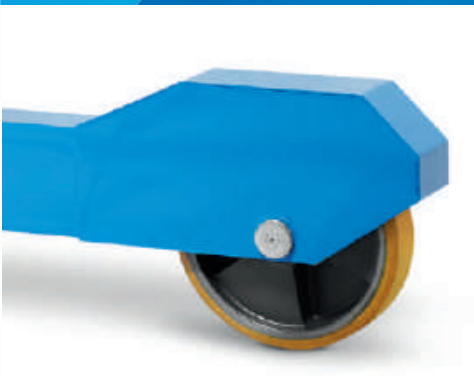

ART.

222

3000 Kg

2500 Kg

2200 Kg

1750 Kg

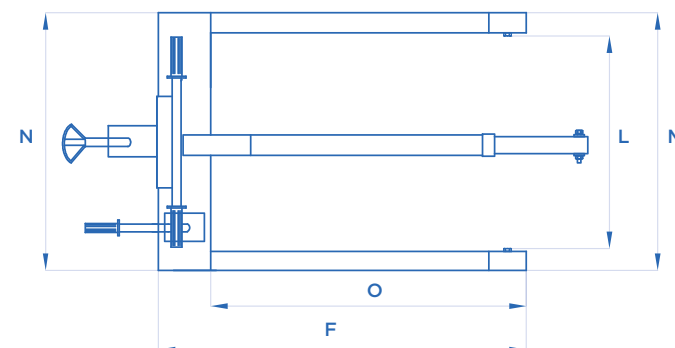

ART.		A mm	B mm	C mm	D mm	E mm	F mm	G mm	H mm	I mm	L mm	M mm	N mm	O mm	KG
222		2220	1600	3250	3800	2270	2350	340	370	750	1230	1460	1460	1860	520

ART. 222/A

OPTIONAL



3000 Kg





## GRU IDRAULICHE A CARRELLO PIEGHEVOLI

FOLDING HYDRAULIC CRANES  
GRUES HYDRAULIQUES PLIANTES  
ZUSAMMENKLAPPBARE HYDRAULIKKRÄNE



ART. GP10/DE

### TRACCIATO TECNICO COSTRUTTIVO

- Pieghevoli in pochi secondi, ingombro irrisorio in fase di riposizione.
- Lo stelo rettificato e cromato garantisce un'alta affidabilità nel tempo.
- Braccio allungabile in quattro posizioni di lavoro.
- Ruote posteriori girevoli per la massima manovrabilità.
- Gancio girevole a 360°.
- Valvola di protezione contro i sovraccarichi incorporata.
- Comando di discesa a velocità controllata.
- Pompa idraulica ad una velocità (GP05/S - GP10/S).
- Pompa idraulica a due velocità (GP05/DE - GP10/DE).
- Dotata di ruote in gomma (GP05/S - GP05/DE).
- Dotata di ruote in gomma e nylon (GP10/S - GP10/DE).

### TECHNICAL AND STRUCTURAL LAY-OUT

- Foldable in just a few seconds and so small when stored.
- Ground chrome-plated rod for top reliability over time.
- Extendable arm in 4 working positions.
- Revolving rear wheels to move it easily.
- 360° revolving hook.
- Safety valve to avoid any possible overload.
- Descent control device with a controlled speed.
- One speed hydraulic pump (GP05/S - GP10/S).
- Two speed hydraulic pump (GP05/DE - GP10/DE).
- Rubber wheels (GP05/S - GP05/DE).
- Rubber and nylon wheels (GP10/S - GP10/DE).





### RELEVÉ TECHNIQUE

- Se plie en quelques secondes et se range dans un mouchoir de poche.
- Vérin en acier spécial, rectifié et chromé, robuste et résistant.
- Flèche extensible: 4 positions de travail possibles.
- Roues arrière pivotantes pour faciliter les déplacements.
- Crochet pivotant à 360°.
- Soupape de sécurité anti-surcharge.
- Commande de descente à vitesse contrôlée.
- Pompe hydraulique à une vitesse (GP05/S - GP10/S).
- Pompe hydraulique à deux vitesses (GP05/DE - GP10/DE).
- Roues en caoutchouc (GP05/S - GP05/DE).
- Roues en caoutchouc et nylon (GP10/S - GP10/DE).

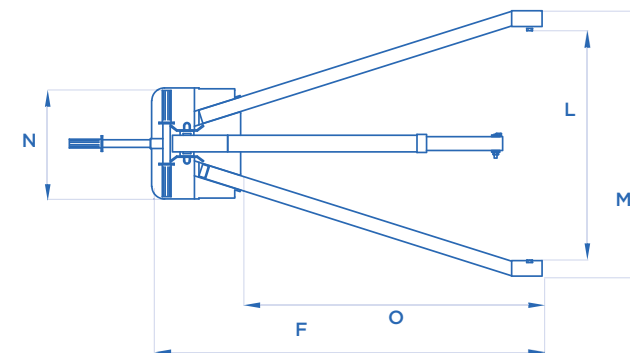
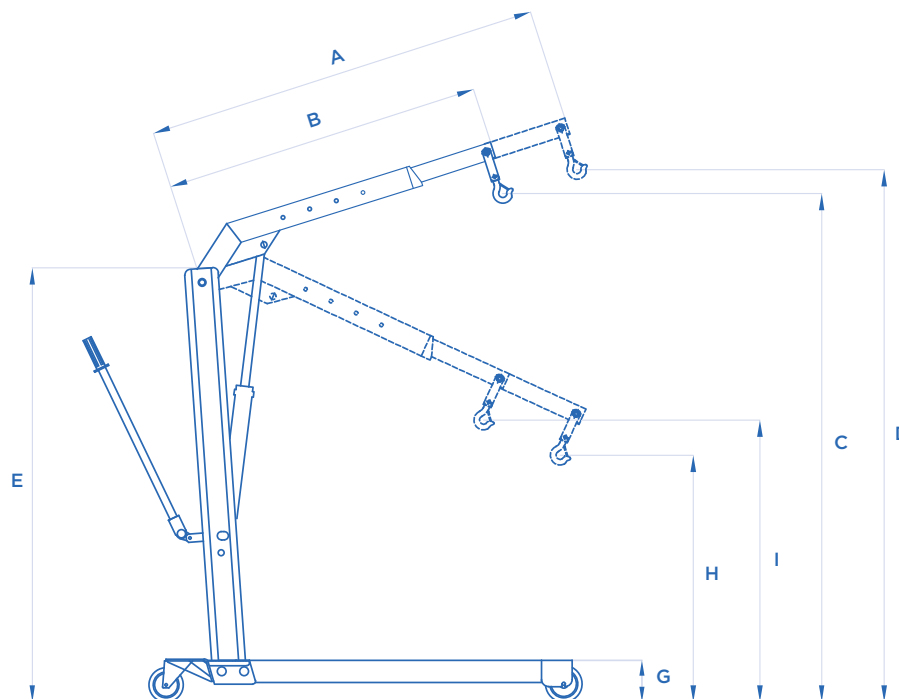
### TECHNISCHE UND KONSTRUKTIVE ANGABEN

- In wenigen Sekunden zusammenklappbar und mit einem lächerlich Lagerfläche wenn es positioniert ist.
- Verchromte und schleifende Kolben, der eine große Zuverlässigkeit im Laufe der Zeit garantiert.
- Ausziehbarer Arm in vier Arbeitspositionen.
- Drehbare Hinterrädern, um die maximale Wendigkeit zu sichern.
- 360° drehbare Haken.
- Angebaut Überlastventil gegen jeder Überlastung.
- Abstiegskontrolle mit einer kontrollierten Geschwindigkeit.
- Einstufige hydraulische Pumpe (GP05/S - GP10/S).
- Zweistufige hydraulische Pumpe (GP05/DE - GP10/DE).
- Mit Gummirädern (GP05/S - GP05/DE).
- Mit Gummi- und Nylonrädern (GP10/S - GP10/DE).



ART.				
<b>GP05/S</b> <b>GP05/DE</b>	500 Kg	400 Kg	250 Kg	150 Kg
<b>GP10/S</b> <b>GP10/DE</b>	1000 Kg	800 Kg	500 Kg	300 Kg

ART.		<b>A</b> mm	<b>B</b> mm	<b>C</b> mm	<b>D</b> mm	<b>E</b> mm	<b>F</b> mm	<b>G</b> mm	<b>H</b> mm	<b>I</b> mm	<b>L</b> mm	<b>M</b> mm	<b>N</b> mm	<b>O</b> mm	
<b>GP05/S</b> <b>GP05/DE</b>	500 Kg	1300	1000	2130	2360	1570	1540	150	400	600	780	900	400	1160	80
<b>GP10/S</b> <b>GP10/DE</b>	1000 Kg	1470	1170	2180	2320	1700	1740	180	550	725	840	980	450	1325	122



## GRU IDRAULICHE A CARRELLO PIEGHEVOLI

FOLDING HYDRAULIC CRANES  
GRUES HYDRAULIQUES PLIANTES  
ZUSAMMENKLAPPBARE HYDRAULIKKRÄNE



### TRACCIATO TECNICO COSTRUTTIVO

- Pieghevoli in pochi secondi, ingombro irrisorio in fase di riposizione.
- Lo stelo rettificato e cromato garantisce un'alta affidabilità nel tempo.
- Braccio allungabile in quattro posizioni di lavoro.
- Ruote posteriori girevoli per la massima manovrabilità.
- Gancio girevole a 360°.
- Valvola di protezione contro i sovraccarichi incorporata.
- Comando di discesa a velocità controllata.
- Pompa idraulica a due velocità.
- Dotata di ruote in poliuretano.

### TECHNICAL AND STRUCTURAL LAY-OUT

- Foldable in just a few seconds and so small when stored.
- Ground chrome-plated rod for top reliability over time.
- Extendable arm in 4 working positions.
- Revolving rear wheels to move it easily.
- 360° revolving hook.
- Safety valve to avoid any possible overload.
- Descent control device with a controlled speed.
- Two speed hydraulic pump.
- Polyurethane wheels.

### RELEVÉ TECHNIQUE



- Se plie en quelques secondes et se range dans un mouchoir de poche.
- Vérin en acier spécial, rectifié et chromé, robuste et résistant.
- Flèche extensible: 4 positions de travail possibles.
- Roues arrière pivotantes pour faciliter les déplacements.
- Crochet pivotant à 360°.
- Soupape de sécurité anti-surcharge.
- Commande de descente à vitesse contrôlée.
- Pompe hydraulique à deux vitesses.
- Roues en polyuréthane.

### TECHNISCHE UND KONSTRUKTIVE ANGABEN

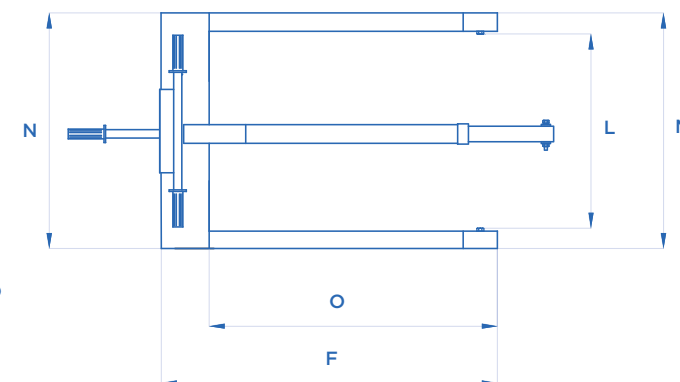
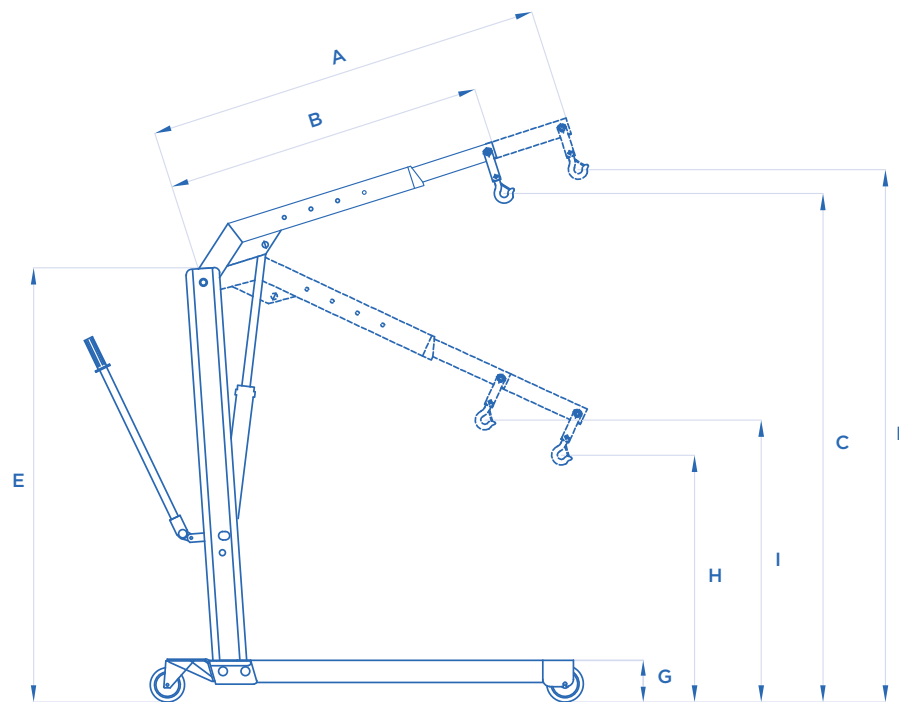
- In wenigen Sekunden zusammenklappbar und mit einem lächerlich Lagerfläche wenn es positioniert ist.
- Verchromte und schleifende Kolben, der eine große Zuverlässigkeit im Laufe der Zeit garantiert.
- Ausziehbare Arm in vier Arbeitspositionen.
- Drehbare Hinterrädern, um die maximale Wendigkeit zu sichern.
- 360° drehbare Haken.
- Angebaut Überlastventil gegen jeder Überlastung.
- Abstiegskontrolle mit einer kontrollierten Geschwindigkeit.
- Zweistufige hydraulische Pumpe.
- Mit Polyurethanrädern.



ART.				
<b>GP12/DE</b>	1200 Kg	900 Kg	800 Kg	700 Kg

ART.		A mm	B mm	C mm	D mm	E mm	F mm	G mm	H mm	I mm	L mm	M mm	N mm	O mm	
<b>GP12/DE</b>	1200 Kg	1490	1190	2140	2355	1600	1600	135	1450	1450	1005	1170	375	1110	125



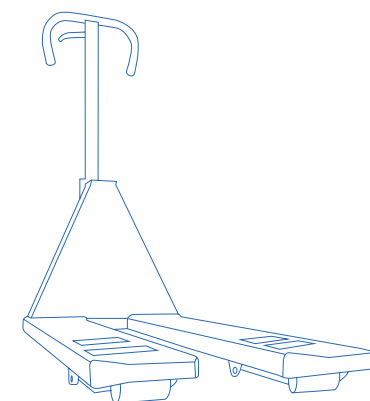

## **ELEVATORI E TRANSPALLET**

ELEVATORS AND TRANSPALLETS  
ELEVATEURS ET TRANSPALLETES  
HUBWAGEN UND PALETTENHUBWAGEN

Made in Italy 

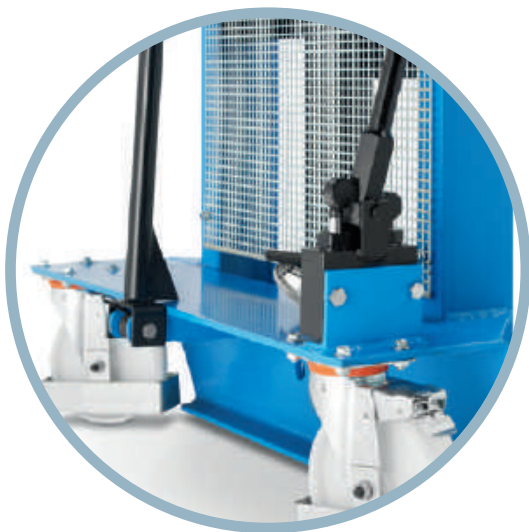

## TRACCIATO TECNICO COSTRUTTIVO

- Carrelli elevatori manuali.
- Altezza minima da terra di soli 90 mm.
- Rapidità di sollevamento grazie alla pompa a due velocità.
- Forche regolabili in larghezza per la massima versatilità.
- Movimentazione facile grazie alle ruote posteriori girevoli di grandi dimensioni complete di freno di stazionamento.
- Rulli anteriori in poliuretano.
- Comando di discesa a velocità controllata "uomo presente".
- Grande altezza di sollevamento.

## TECHNICAL AND STRUCTURAL LAY-OUT

- Manual forklifts.
- Minimum height from the ground 90 mm only.
- Two-speed pump to lift quickly.
- Width-adjustable forks for the maximum versatility.
- Move easily thanks to big rear turning wheels equipped with a stationing brake.
- Front rolls made of polyurethane.
- "Man-standing by" descent control device with controlled speed.
- Great lifting height.

## RELEVÉ TECHNIQUE

- Transpalettes manuels.
- Hauteur minimum 90 mm seulement.
- Levage très rapide grâce à une pompe à deux vitesses.
- Fourches réglables en largeur pour une polyvalence maximale.
- Mouvement facile grâce aux grandes roues arrières pivotantes avec frein de stationnement.
- Rouleaux avant en polyuréthane.
- Commande de descente de type « homme-mort » à vitesse contrôlée.
- Grande hauteur de levage.

## TECHNISCHE UND KONSTRUKTIVE ANGABEN

- Manueller Hubwagen.
- Mindestbodenhöhe von nur 90 mm.
- Sehr schnelle Hebung dank eine zweistufige Pumpe.
- Breitverstellbare Gabeln für eine maximale Vielseitigkeit.
- Einfache Bewegung dank die zwei große Drehhinterrädern, die mit einer Feststellbremse ausgerüstet sind.
- Vorderrollen aus Polyurethane.
- Totmann -Abstiegskontrolle mit einer kontrollierten Geschwindigkeit.
- Größe Hubhöhe.

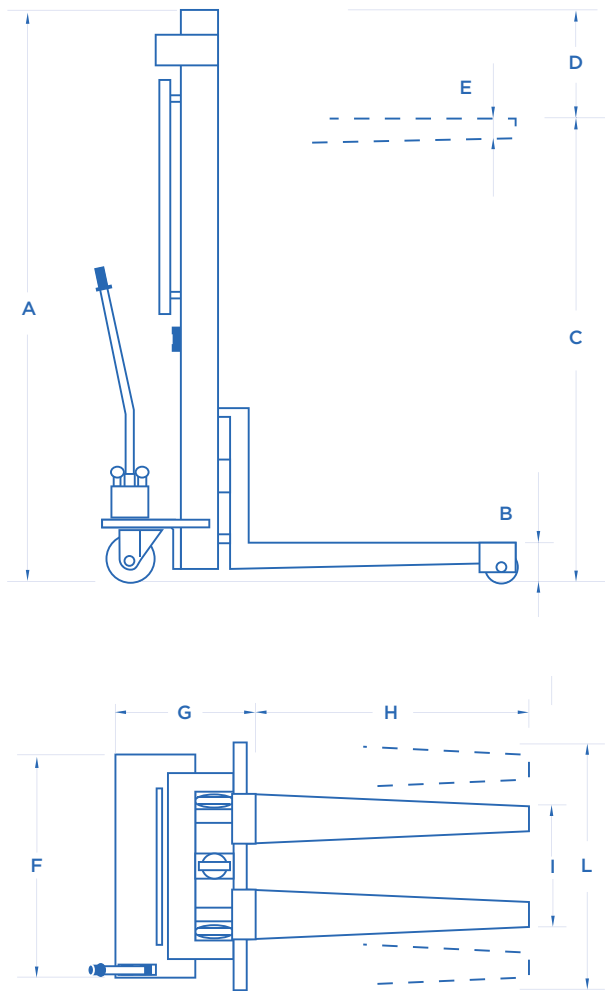

ART. 147

OPTIONAL  
ART. 146/M



ART. 147/A

OPTIONAL  
ART. 206/M



ART. 147 • 147/A

Braccio a gru regolabile

Crane arm adjustable

Potence

Aufsetzbarer und  
ausziehbarer Kranarm

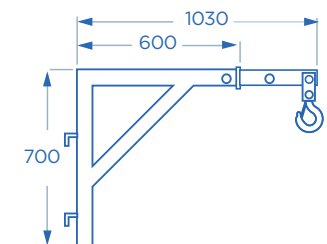

ART.		A mm	B mm	C mm	D mm	E mm	F mm	G mm	H mm	I mm	L mm
------	--	------	------	------	------	------	------	------	------	------	------

146/M	500 Kg	2050	90	1600	450	50	750	470	900	550	715
206/M	1000 Kg	2050	90	1600	450	50	950	500	1000	480	1000

ART.			
------	--	--	--

147	400 Kg	250 Kg	150 Kg
147/A	500 Kg	400 Kg	250 Kg





**ART. 223/M**

## TRACCIATO TECNICO COSTRUTTIVO

- Carrelli transpallet professionali.
- Robusta struttura sovradimensionata realizzata esclusivamente in acciaio.
- Finecorsa meccanico di sicurezza.
- Comando di discesa manuale.
- Leverismo anteriore in alluminio.
- Comando di discesa a velocità controllata "uomo presente".
- Valvola di sicurezza contro i sovraccarichi.
- Ruote posteriori in alluminio montate su cuscinetti.
- Doppi rulli anteriori in poliuretano.
- Ruote posteriori ricoperte in poliuretano.

## TECHNICAL AND STRUCTURAL LAY-OUT

- Professional forklifts.
- Sturdy oversized structure fully made of steel.
- Mechanical safety limit switch.
- Descent control by hand.
- Front linkage made of aluminium.
- "Man-standing by" descent control device with controlled speed.
- Safety valve to avoid any possible overload.
- Rear wheels made of aluminium, mounted on bearings.
- Double front rolls made of polyurethane.
- Rear wheels covered with polyurethane.





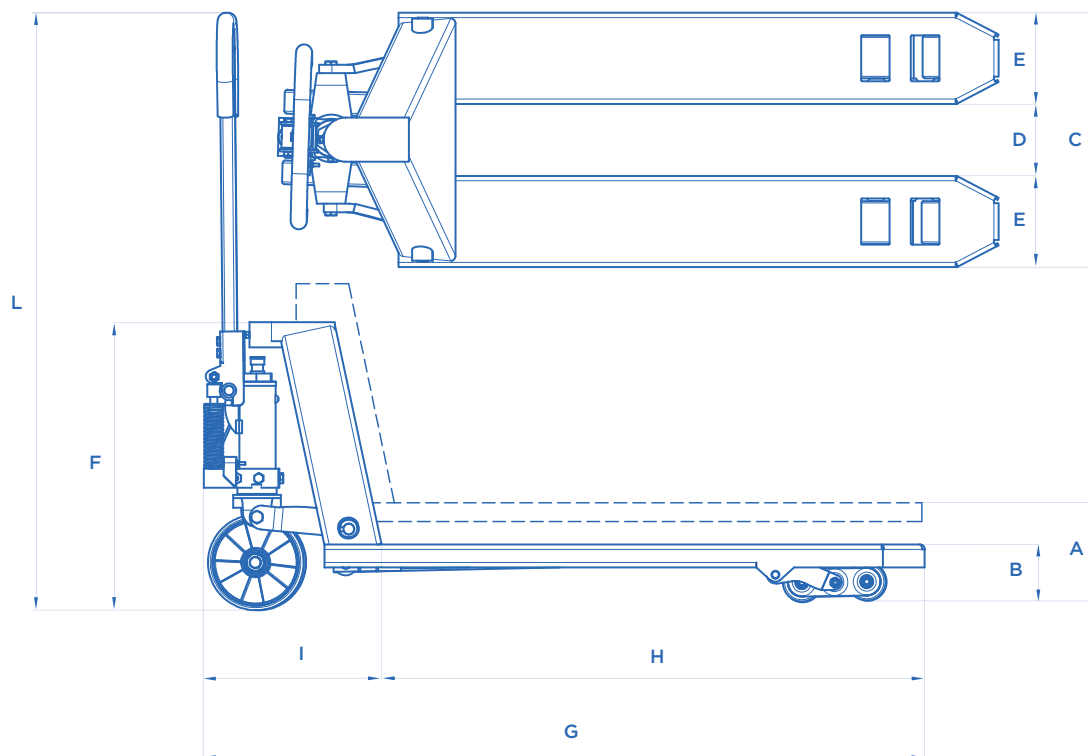

## RELEVÉ TECHNIQUE

- Transpalettes professionnelles.
- Structure surdimensionnée très robuste réalisée exclusivement en acier.
- Fin course mécanique de sécurité.
- Commande de descente manuel.
- Barre de levage antérieure en aluminium.
- Commande de descente de type « homme-mort » à vitesse contrôlée.
- Soupape de sécurité anti-surcharge.
- Roues arrières en aluminium, montées sur roulement.
- Double rouleaux avant en polyuréthane.
- Roues arrières couverture polyuréthane.

## TECHNISCHE UND KONSTRUKTIVE ANGABEN

- Professioneller Palettenhubwagen.
- Überdimensionierte Struktur, die nur aus Stahl realisiert ist.
- Mechanischer Sicherheitsendschalter.
- Mit einer Manuelle Abstiegskontrolle.
- Vordere Hebestange aus Aluminium.
- Totmann -Abstiegskontrolle mit einer kontrollierten Geschwindigkeit.
- Überlastventil gegen jeder Überlastung.
- Hinterrädern aus Aluminium, die auf Lagern montiert sind.
- Doppelvorderrollen aus Polyurethan.
- Hinterrädern aus Polyurethan bedeckt.



ART.		A  mm	B  mm	C  mm	D  mm	E  mm	F  mm	G  mm	H  mm	I  mm	L  mm	 KG
<b>149/M</b>	2000 Kg	200	85	525	185	165	560	1550	1150	400	1200	110
<b>223/M</b>	3000 Kg	200	85	525	150	185	560	1560	1160	400	1200	130



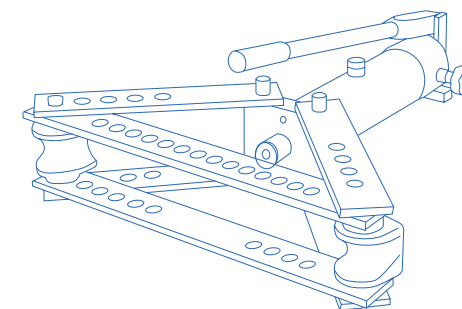

## **CURVATUBI**

PIPE BENDING MACHINES  
CINTREUSES  
ROHRBIEGEMASCHINEN

Made in Italy 

# RAPID T10 LINE

## CURVATUBI IDRAULICI

HYDRAULIC PIPE-BENDERS  
CINTREUSES HYDRAULIQUES  
HYDRAULISCHE ROHRBIEGEMASCHINEN



## OPTIONAL

### TREPPIEDE

Tripod  
Trépied  
Dreibein-Untergestell



ART. TP/1



ART. MINI • A • B • C • D

ART. TP/2



ART. E • F • G

ART.	MATRICI CONTENUTE • SUPPLIED FORMES • FORMES FOURNIES • AUSGESTATTENE BIEGEFORMEN											
<b>MINI</b>	3/8"	1/2"	3/4"	1"								
<b>A</b>	3/8"	1/2"	3/4"	1"	1 1/4"							
<b>B</b>	3/8"	1/2"	3/4"	1"	1 1/4"	1 1/2"						
<b>C</b>	3/8"	1/2"	3/4"	1"	1 1/4"	1 1/2"	2"					
<b>D</b>	3/8"	1/2"	3/4"	1"	1 1/4"	1 1/2"	2"	2 1/2"	3"			
<b>E</b>	3/8"	1/2"	3/4"	1"	1 1/4"	1 1/2"	2"	2 1/2"	3"	4"		
<b>F</b>				1"	1 1/4"	1 1/2"	2"	2 1/2"	3"	4"	5"	
<b>G</b>							2"	2 1/2"	3"	4"	5"	6"

### RAPID T10

Gli apparecchi curvatubi RAPID T10 a piastra superiore scorrevole e con piastra inferiore a lettura costante, curvano a freddo senza riempimento tubi gas e acqua, senza saldatura, UNI EN10255 (BS1387 - UNI3824).

The pipe bending machines RAPID T10 with sliding top plate and constant reading lower plate cold-bend gas and water pipes, without welding, UNI EN10255 (BS1387 - UNI3824).

Les cintreuses RAPID T10 avec la plaque supérieure coulissante et la plaque inférieure à lecture constante, assurent le cintrage des tubes gaz et eau sans soudure, UNI EN10255 (BS1387 - UNI3824).

Mit dem Rohrbieger RAPID T10 mit gleitender Oberplatte und konstant ablesbarer Unterplatte, Gas- und Wasserrohre, ohne Schweißnähte, UNI EN10255 (BS1387 - UNI3824).

## CURVATUBI ELETTROIDRAULICI

ELECTROHYDRAULIC PIPE-BENDERS

CINTREUSES ELECTROHYDRAULIQUES

ELEKTROHYDRAULISCHE ROHRBIEGEMASCHINEN

RAPID T10/M  
LINE

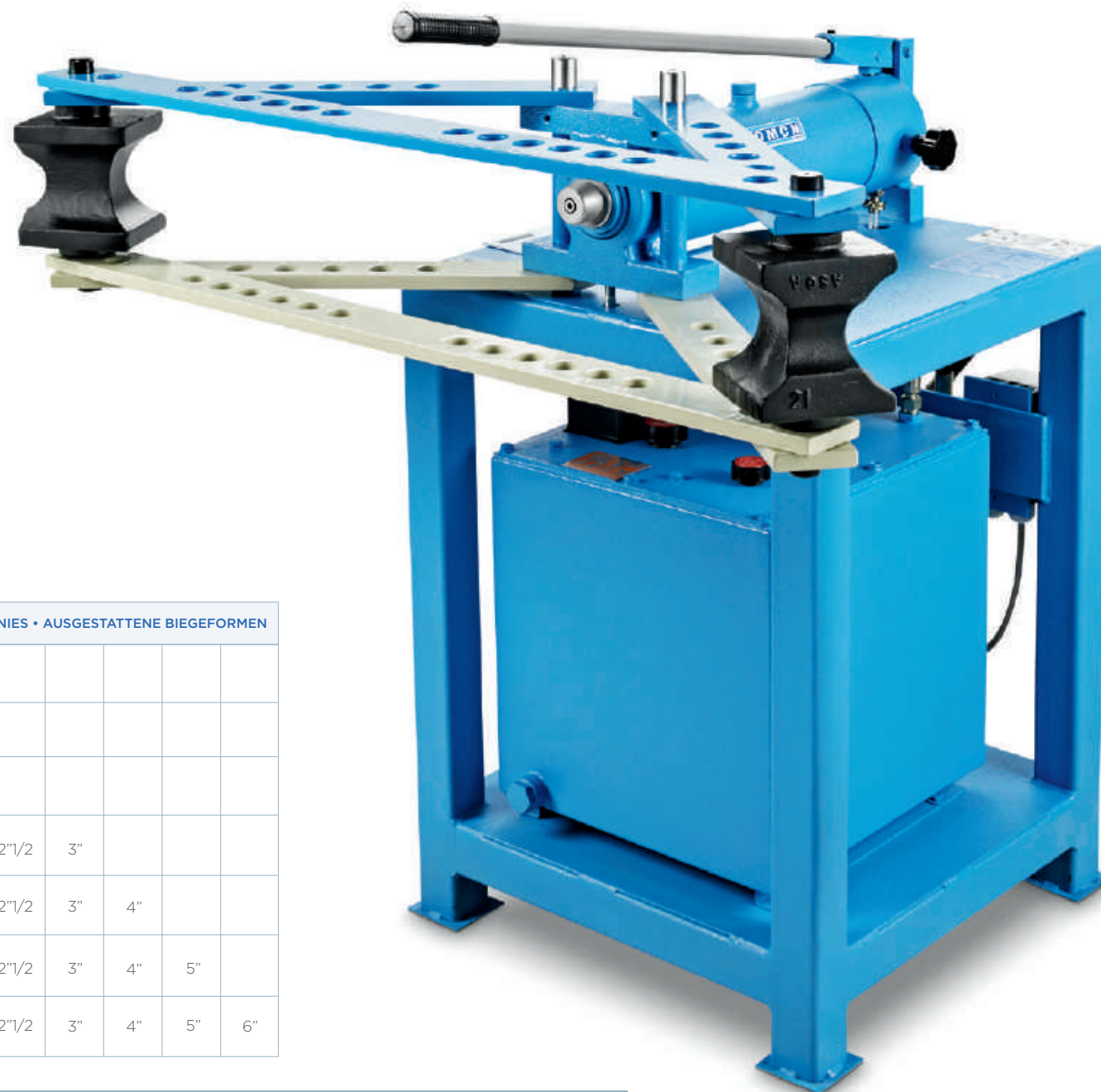

ART.	MATRICI CONTENUTE • SUPPLIED FORMES • FORMES FOURNIES • AUSGESTATTENE BIEGEFORMEN											
<b>A/M</b>	3/8"	1/2"	3/4"	1"	1"1/4"							
<b>B/M</b>	3/8"	1/2"	3/4"	1"	1"1/4"	1"1/2"						
<b>C/M</b>	3/8"	1/2"	3/4"	1"	1"1/4"	1"1/2"	2"					
<b>D/M</b>	3/8"	1/2"	3/4"	1"	1"1/4"	1"1/2"	2"	2"1/2"	3"			
<b>E/M</b>	3/8"	1/2"	3/4"	1"	1"1/4"	1"1/2"	2"	2"1/2"	3"	4"		
<b>F/M</b>				1"	1"1/4"	1"1/2"	2"	2"1/2"	3"	4"	5"	
<b>G/M</b>							2"	2"1/2"	3"	4"	5"	6"

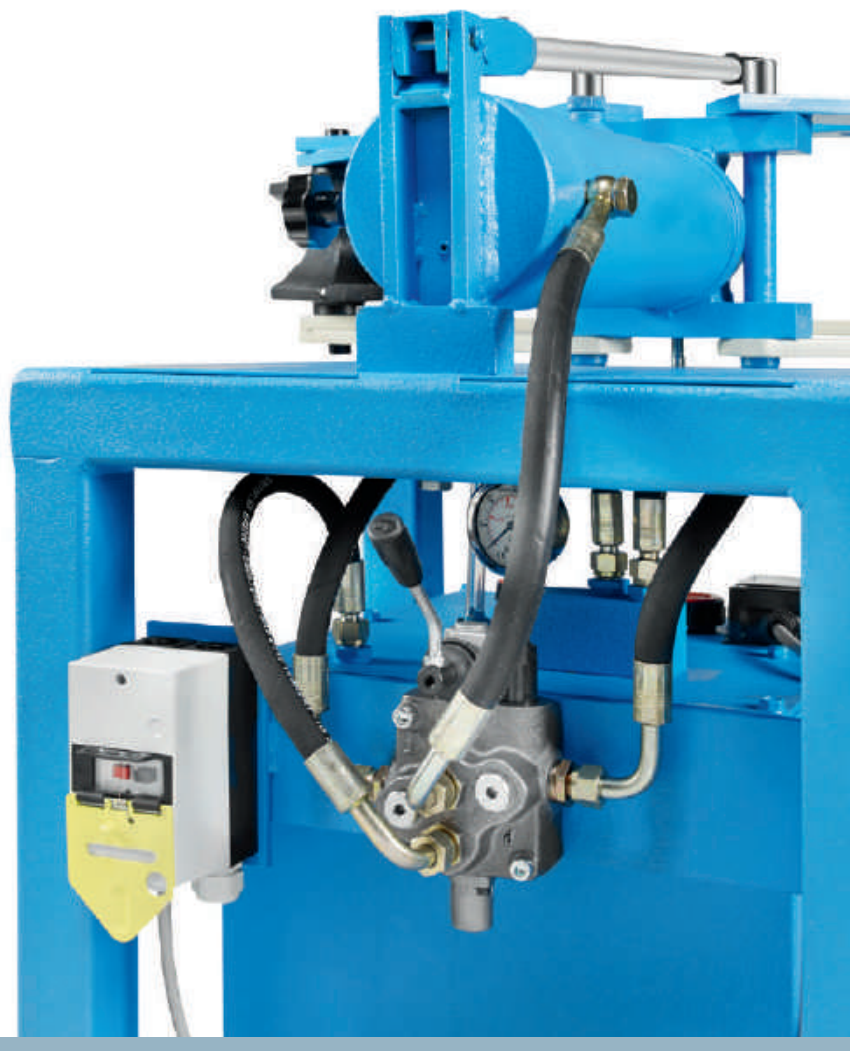

## RAPID T10/M

Gli apparecchi a motore RAPID T10/M, dotati di una silenziosa centralina elettroidraulica comandata a distanza da un distributore a due vie, sono veramente pratici per la particolare accuratezza con la quale sono stati studiati. La centralina, a pistoncini radianti, è completa di una valvola di massima che permette lo scarico automatico dell'olio, una volta raggiunto il massimo sforzo, mantenendo inalterata la pressione di esercizio. Ognuno di questi modelli è dotato inoltre di un solido banco di lavoro a due piani. Sul piano inferiore viene collocata la centralina idraulica e su quello superiore la macchina curvatubi. La novità assoluta dei RAPID T10/M è rappresentata dal fatto che, in caso di necessità, possono essere impiegati anche con funzionamento manuale. Gli stessi sono indicati per piegare tubi gas e acqua, senza saldatura, UNI EN10255 (BS1387 - UNI3824).

The motor-driven pipe bending machines RAPID T10/M fitted with silent electrohydraulic gearbox, remote-controlled by a two-way distributor, are practical indeed for the special accuracy with which they have been designed. The gearbox with radiant pistons is complete with a limit valve that enables an automatic oil discharge once the maximum stress has been reached, keeping the working pressure unaltered. Each one of these models is also fitted with a sturdy two-storey working table. The hydraulic gearbox is placed on the lower storey, while the pipe-bending machine is placed on the upper storey. The absolute newness of the RAPID T10/M is represented by the fact that they can be used also by hand if needed. The same are suitable to bend gas and water pipes without welding, UNI EN10255 (BS1387 - UNI3824).

Les cintruses à moteur RAPID T10/M sont équipées d'un distributeur électrohydraulique silencieux commandé à distance par un distributeur à deux voies. Leur étude soignée en font des appareils très pratiques. Le distributeur à pistoncini radiants, est pourvu d'une soupape qui permet l'écoulement automatique de l'huile, une fois l'effort maximum atteint, en maintenant la pression de travail constante. Chacun de ces modèles est équipé en outre d'un plan de travail résistant, à deux étages. Sur l'étage inférieur est installé le distributeur hydraulique et à l'étage supérieur la machine à cintrer les tubes. La principale nouveauté des RAPID T10/M est représentée par le fait, qu'en cas de nécessité, on peut aussi les faire fonctionner manuellement. Les mêmes sont indiqués pour plier tuyaux gaz et eau, sans soudure, UNI EN10255 (BS1387 - UNI3824).

Die motorbetriebenen Rohrbiegemaschinen RAPID T10/M sind mit einem durch ein Zweiwegeventil ferngesteuerten, geräuscharmen Elektrohydraulikaggregat ausgestattet. Aufgrund ihrer durchdachten Technik, sind die Geräte insbesondere für Arbeiten gedacht, bei denen es auf hohe Genauigkeit ankommt. Darüber hinaus sind die Geräte besonders praktisch in der Handhabung. Das Aggregat ist mit Radialkolben und mit einem Max-Druckventil ausgestattet, wodurch bei unverminderter Arbeitsleistung das Öl automatisch abfließt, wenn maximaler Druck erreicht wird. Jede dieser Maschinen zeichnet sich zudem durch eine stabile Konstruktion auf zwei Ebenen aus; unten befindet sich das Hydraulikaggregat und oben die Rohrbiegemaschine. Absolut neu die RAPID T10/M Geräte können notfalls auch per Hand bedient werden. Sie können auch verwendet werden für Gas- und Wasserrohre ohne Schweißnähte, UNI EN10255 (BS1387 - UNI3824).

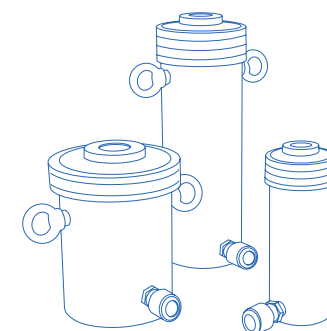

## **POMPE E CILINDRI IDRAULICI PER APPLICAZIONI INDUSTRIALI**

HYDRAULIC PUMPS AND CYLINDERS FOR INDUSTRIAL SOLUTIONS  
POMPES ET VERINS HYDRAULIQUES : SOLUTIONS POUR L'INDUSTRIE  
PUMPEN UND ZYLINDER FÜR INDUSTRIELLE ANWENDUNGEN

Made in Italy 



# CILINDRI IDRAULICI A SEMPLICE EFFETTO

SINGLE ACTING HYDRAULIC CYLINDERS

VÉRINS SIMPLE EFFET HYDRAULIQUES

EINFACHWIRKENDE HYDRAULIKZYLINDER



Ritorno a gravità  
Load return  
Retour sous charge  
Lastrückzug

ART.	TON	Pressione Pressure Pression Druck	Capacità olio Oil capacity Capacité huile Ölvolumen	A mm	B mm	C mm	D mm	KG
<b>359</b>	5	700 bar	15,3 cm <sup>3</sup>	76	60	16	30	0,6
<b>359/A</b>	5	700 bar	33,6 cm <sup>3</sup>	115	80	35	30	0,8
<b>360</b>	10	700 bar	25,4 cm <sup>3</sup>	76	60	16	40	0,9
<b>360/A</b>	10	700 bar	55,6 cm <sup>3</sup>	115	80	35	40	1,2
<b>361</b>	20	700 bar	26,4 cm <sup>3</sup>	78	70	8	60	2,7
<b>361/A</b>	20	700 bar	66,2 cm <sup>3</sup>	105	85	20	60	3,3
<b>362</b>	30	700 bar	40,1 cm <sup>3</sup>	78	70	8	75	3,8
<b>362/A</b>	30	700 bar	100,4 cm <sup>3</sup>	105	85	20	75	4,5
<b>363</b>	50	700 bar	39,2 cm <sup>3</sup>	75	70	5	90	6
<b>363/A</b>	50	700 bar	117,7 cm <sup>3</sup>	100	85	15	90	7,1



Ritorno a molla  
Spring return  
Retour par ressort  
Federrückzug

ART.	TON	Pressione Pressure Pression Druck	Capacità olio Oil capacity Capacité huile Ölvolumen	A mm	B mm	C mm	D mm	KG
<b>359/M</b>	5	700 bar	15,3 cm <sup>3</sup>	76	60	16	30	0,6
<b>359/AM</b>	5	700 bar	33,6 cm <sup>3</sup>	115	80	35	30	0,8
<b>360/M</b>	10	700 bar	25,4 cm <sup>3</sup>	76	60	16	40	0,9
<b>360/AM</b>	10	700 bar	55,6 cm <sup>3</sup>	115	80	35	40	1,2
<b>361/M</b>	20	700 bar	26,4 cm <sup>3</sup>	78	70	8	60	2,7
<b>361/AM</b>	20	700 bar	66,2 cm <sup>3</sup>	105	85	20	60	3,3
<b>362/M</b>	30	700 bar	40,1 cm <sup>3</sup>	78	70	8	75	3,8
<b>362/AM</b>	30	700 bar	100,4 cm <sup>3</sup>	105	85	20	75	4,5
<b>363/M</b>	50	700 bar	39,2 cm <sup>3</sup>	75	70	5	90	6
<b>363/AM</b>	50	700 bar	117,7 cm <sup>3</sup>	100	85	15	90	7,1

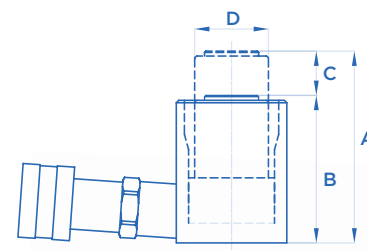

## INGOMBRO RIDOTTO

LOW HEIGHT  
EXTRA-PLATS  
KURZHUB-ZYLINDER



## IMPIEGHI GENERICI

GENERAL PURPOSE

TOUS USAGES

ALLZWECK-HYDRAULIKZYLINDER

CE Made in Italy 

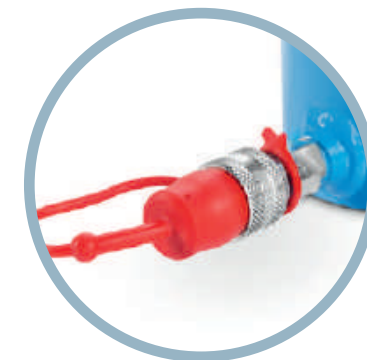
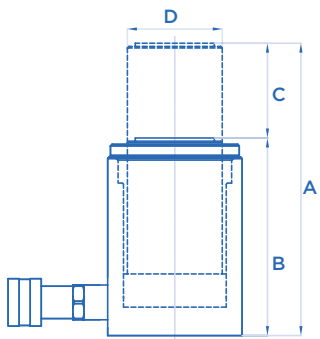

Ritorno a gravità  
Load return  
Retour sous charge  
Lastrückzug



Ritorno a molla  
Spring return  
Retour par ressort  
Federrückzug

**OPTIONAL** Pag. 297

ART.	TON	Pressione Pressure Pression Druck	Capacità olio Oil capacity Capacité huile Ölvolumen	A mm	B mm	C mm	D mm	KG	ART.	TON	Pressione Pressure Pression Druck	Capacità olio Oil capacity Capacité huile Ölvolumen	A mm	B mm	C mm	D mm	KG
<b>359/B</b>	5	700 bar	52,8 cm <sup>3</sup>	155	100	55	30	1	<b>359/BM</b>	5	700 bar	52,8 cm <sup>3</sup>	155	100	55	30	1
<b>359/C</b>	5	700 bar	72 cm <sup>3</sup>	195	120	75	30	1,2	<b>359/CM</b>	5	700 bar	72 cm <sup>3</sup>	195	120	75	30	1,2
<b>359/D</b>	5	700 bar	100,8 cm <sup>3</sup>	255	150	105	30	1,5	<b>359/DM</b>	5	700 bar	100,8 cm <sup>3</sup>	255	150	105	30	1,5
<b>360/B</b>	10	700 bar	87,4 cm <sup>3</sup>	155	100	55	40	1,6	<b>360/BM</b>	10	700 bar	87,4 cm <sup>3</sup>	155	100	55	40	1,6
<b>360/C</b>	10	700 bar	119,2 cm <sup>3</sup>	195	120	75	40	1,9	<b>360/CM</b>	10	700 bar	119,2 cm <sup>3</sup>	195	120	75	40	1,9
<b>360/D</b>	10	700 bar	167 cm <sup>3</sup>	255	150	105	40	2,4	<b>360/DM</b>	10	700 bar	167 cm <sup>3</sup>	255	150	105	40	2,4
<b>361/B</b>	20	700 bar	132,4 cm <sup>3</sup>	145	105	40	60	4,1	<b>361/BM</b>	20	700 bar	132,4 cm <sup>3</sup>	145	105	40	60	4,1
<b>361/C</b>	20	700 bar	198,6 cm <sup>3</sup>	185	125	60	60	4,9	<b>361/CM</b>	20	700 bar	198,6 cm <sup>3</sup>	185	125	60	60	4,9
<b>361/D</b>	20	700 bar	331 cm <sup>3</sup>	265	165	100	60	6,5	<b>361/DM</b>	20	700 bar	331 cm <sup>3</sup>	265	165	100	60	6,5
<b>362/B</b>	30	700 bar	200,8 cm <sup>3</sup>	145	105	40	75	5,6	<b>362/BM</b>	30	700 bar	200,8 cm <sup>3</sup>	145	105	40	75	5,6
<b>362/C</b>	30	700 bar	301,2 cm <sup>3</sup>	185	125	60	75	6,8	<b>362/CM</b>	30	700 bar	301,2 cm <sup>3</sup>	185	125	60	75	6,8
<b>362/D</b>	30	700 bar	502 cm <sup>3</sup>	265	165	100	75	9,2	<b>362/DM</b>	30	700 bar	502 cm <sup>3</sup>	265	165	100	75	9,2
<b>363/B</b>	50	700 bar	274,7 cm <sup>3</sup>	140	105	35	90	9,2	<b>363/BM</b>	50	700 bar	274,7 cm <sup>3</sup>	140	105	35	90	9,2
<b>363/C</b>	50	700 bar	431,7 cm <sup>3</sup>	180	125	55	90	11	<b>363/CM</b>	50	700 bar	431,7 cm <sup>3</sup>	180	125	55	90	11
<b>363/D</b>	50	700 bar	745,7 cm <sup>3</sup>	260	165	95	90	15,2	<b>363/DM</b>	50	700 bar	745,7 cm <sup>3</sup>	260	165	95	90	15,2

## CORSA LUNGA

LONG STROKE  
GRANDE COURSE  
LANGHUBZYLINDER



Ritorno a molla  
Spring return  
Retour par ressort  
Federrückzug

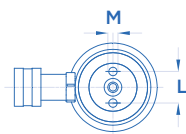
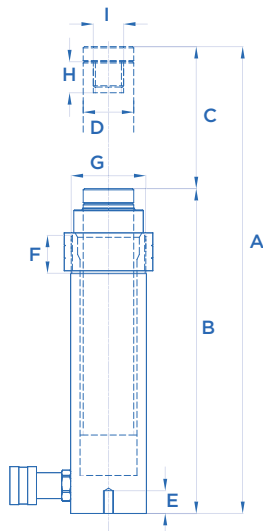

**OPTIONAL** Pag. 297

ART.	TON	Pressione Pressure Pression Druck	Capacità olio Oil capacity Capacité huile Ölvolumen	A mm	B mm	C mm	D mm	E mm	F mm	G mm	H mm	I mm	L mm	M mm	KG
<b>359/EM</b>	5	700 bar	120 cm <sup>3</sup>	370	245	125	30	20	25	M50X2	12	M16X2	32	M8	2,5
<b>359/FM</b>	5	700 bar	144 cm <sup>3</sup>	420	270	150	30	20	25	M50X2	12	M16X2	32	M8	2,7
<b>359/GM</b>	5	700 bar	178 cm <sup>3</sup>	470	295	175	30	20	25	M50X2	12	M16X2	32	M8	2,9
<b>359/HM</b>	5	700 bar	240 cm <sup>3</sup>	620	370	250	30	20	25	M50X2	12	M16X2	32	M8	3,5
<b>360/EM</b>	10	700 bar	222 cm <sup>3</sup>	405	265	140	40	20	30	M64X2	25	M24X3	45	M8	5,2
<b>360/FM</b>	10	700 bar	333 cm <sup>3</sup>	545	335	210	40	20	30	M64X2	25	M24X3	45	M8	6,4
<b>360/GM</b>	10	700 bar	445 cm <sup>3</sup>	685	405	280	40	20	30	M64X2	25	M24X3	45	M8	7,6
<b>360/HM</b>	10	700 bar	556 cm <sup>3</sup>	825	475	350	40	20	30	M64X2	25	M24X3	45	M8	8,8
<b>361/EM</b>	20	700 bar	529 cm <sup>3</sup>	450	290	160	60	20	30	M84X2	30	M30X3,5	50	M10	11,1
<b>361/FM</b>	20	700 bar	728,2 cm <sup>3</sup>	570	350	220	60	20	30	M84X2	30	M30X3,5	50	M10	13,2
<b>361/GM</b>	20	700 bar	993 cm <sup>3</sup>	730	430	300	60	20	30	M84X2	30	M30X3,5	50	M10	16,1
<b>361/HM</b>	20	700 bar	1158,5 cm <sup>3</sup>	830	480	350	60	20	30	M84X2	30	M30X3,5	50	M10	18
<b>362/EM</b>	30	700 bar	702 cm <sup>3</sup>	420	275	140	75	20	30	M104X2	25	M39X4	65	M10	16,8
<b>362/FM</b>	30	700 bar	1005 cm <sup>3</sup>	540	335	200	75	20	30	M104X2	25	M39X4	65	M10	20,2
<b>362/GM</b>	30	700 bar	1305 cm <sup>3</sup>	660	395	260	75	20	30	M104X2	25	M39X4	65	M10	23,5
<b>362/HM</b>	30	700 bar	1606 cm <sup>3</sup>	780	455	320	75	20	30	M104X2	25	M39X4	65	M10	26,5
<b>363/EM</b>	50	700 bar	1177 cm <sup>3</sup>	445	295	150	90	20	30	M128X1,5	30	M55X3	77	M10	25
<b>363/FM</b>	50	700 bar	1570 cm <sup>3</sup>	545	345	200	90	20	30	M128X1,5	30	M55X3	77	M10	28,9
<b>363/GM</b>	50	700 bar	1962 cm <sup>3</sup>	645	395	250	90	20	30	M128X1,5	30	M55X3	77	M10	32,6
<b>363/HM</b>	50	700 bar	2355 cm <sup>3</sup>	745	445	300	90	20	30	M128X1,5	30	M55X3	77	M10	37,2

## ALTA POTENZA

HIGH TONNAGE  
FORT TONNAGE  
SCHWERLASTZYLINDER

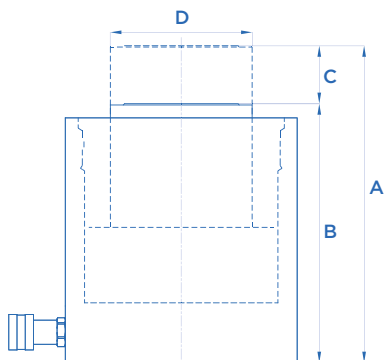

Ritorno a molla  
Spring return  
Retour par ressort  
Federrückzug

ART.	TON	Pressione Pressure Pression Druck	Capacità olio Oil capacity Capacité huile Ölvolumen	A mm	B mm	C mm	D mm	KG
<b>364/M</b>	85	520 bar	794 cm <sup>3</sup>	245	200	45	110	32,5
<b>364/AM</b>	85	520 bar	1677 cm <sup>3</sup>	345	250	95	110	38,6
<b>364/BM</b>	85	520 bar	3090 cm <sup>3</sup>	505	330	175	110	48,5
<b>365/M</b>	125	520 bar	1144 cm <sup>3</sup>	265	220	45	140	48,5
<b>365/AM</b>	125	520 bar	2416 cm <sup>3</sup>	365	270	95	140	59,5
<b>365/BM</b>	125	520 bar	4450 cm <sup>3</sup>	525	350	175	140	77
<b>368/M</b>	190	520 bar	1709 cm <sup>3</sup>	295	250	45	170	91,5
<b>368/AM</b>	190	520 bar	3609 cm <sup>3</sup>	395	300	95	170	110
<b>368/BM</b>	190	520 bar	6648 cm <sup>3</sup>	555	380	175	170	140
<b>368/CM</b>	245	520 bar	2207 cm <sup>3</sup>	305	260	45	210	121
<b>368/DM</b>	245	520 bar	6623 cm <sup>3</sup>	485	350	135	210	163



# CILINDRI IDRAULICI A DOPPIO EFFETTO

DOUBLE ACTING HYDRAULIC CYLINDERS

VÉRINS DOUBLE EFFET HYDRAULIQUES

DOPPELTWIRKENDE HYDRAULIKZYLINDER

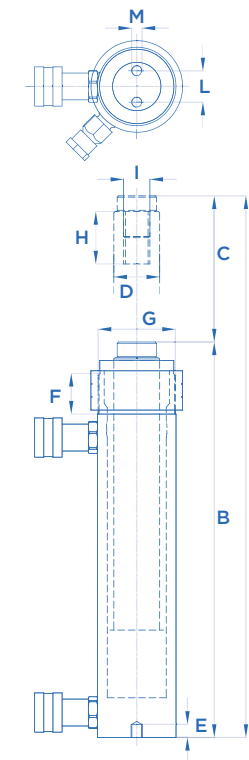

ART.	↑ TON	↓ TON	Pressione Pressure Pression Druck	Capacità olio Oil capacity Capacité huile Ölvolumen	A mm	B mm	C mm	D mm	E mm	F mm	G mm	H mm	I mm	L mm	M mm	KG
<b>369</b>	11	4	700 bar	255,3 cm <sup>3</sup>	445	285	160	35	10	25	M59X2	45	M20X2,5	23	M8	5,5
<b>369/A</b>	11	4	700 bar	516 cm <sup>3</sup>	800	470	330	35	10	25	M59X2	45	M20X2,5	23	M8	8,7
<b>369/D</b>	35	15	700 bar	955 cm <sup>3</sup>	540	350	190	60	14	35	M104X2	45	M20X2,5	60	M10	17,5
<b>369/E</b>	35	15	700 bar	1582 cm <sup>3</sup>	785	470	315	60	14	35	M104X2	45	M20X2,5	60	M10	23,5
<b>369/H</b>	55	24	700 bar	1216 cm <sup>3</sup>	470	320	150	75	20	30	M128X1,5	50	M30X3,5	65	M10	28,2
<b>369/I</b>	55	24	700 bar	2001 cm <sup>3</sup>	670	420	250	75	20	30	M128X1,5	50	M30X3,5	65	M10	36

# CILINDRI IDRAULICI CON PISTONE FORATO

HOLLOW PLUNGER CYLINDERS

VÉRINS À PISTON CREUX

HOHLKOLBENZYLINDER

## SEMPLICE EFFETTO

SINGLE ACTING

SIMPLE EFFET

EINFACHWIRKENDE

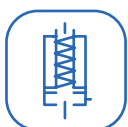

Ritorno a molla  
Spring return  
Retour par ressort  
Federrückzug

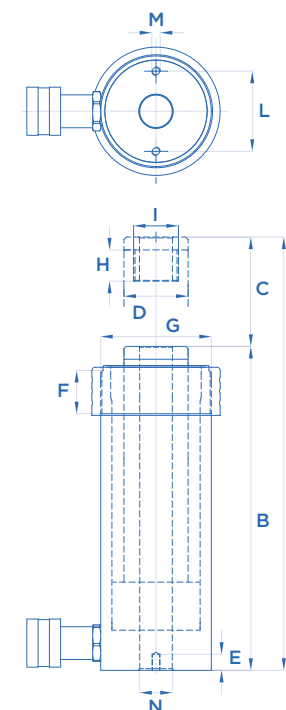

ART.	TON	Pressione Pressure Pression Druck	Capacità olio Oil capacity Capacité huile Ölvolumen	A mm	B mm	C mm	D mm	E mm	F mm	G mm	H mm	I mm	L mm	M mm	N mm	KG
<b>366</b>	12	700 bar	111 cm <sup>3</sup>	265	200	65	40	10	25	M69X2	20	M28X1,5	50	M5	20,5	4
<b>366/A</b>	12	700 bar	15 cm <sup>3</sup>	68	60	8	40	10	25	M69X2	20	M28X1,5	50	M5	20,5	1,6
<b>366/B</b>	12	700 bar	56,4 cm <sup>3</sup>	152	122	32	40	10	25	M69X2	20	M28X1,5	65	M5	20,5	3
<b>367</b>	24	700 bar	471 cm <sup>3</sup>	445	320	125	60	10	35	M104X2	25	M44X2	67	M6	27	14
<b>367/A</b>	24	700 bar	70 cm <sup>3</sup>	193	175	18	60	10	35	M104X2	25	M44X2	67	M6	27	8,5
<b>367/B</b>	37	700 bar	150 cm <sup>3</sup>	230	195	35	75	20	30	M128X1,5	20	M55X2	88	M10	34	16
<b>367/C</b>	37	700 bar	760 cm <sup>3</sup>	535	385	150	75	20	30	M128X1,5	20	M55X2	88	M10	34	25

## DOPPIO EFFETTO

DOUBLE ACTING  
DOUBLE EFFET  
DOPPELTWIRKENDE

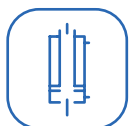
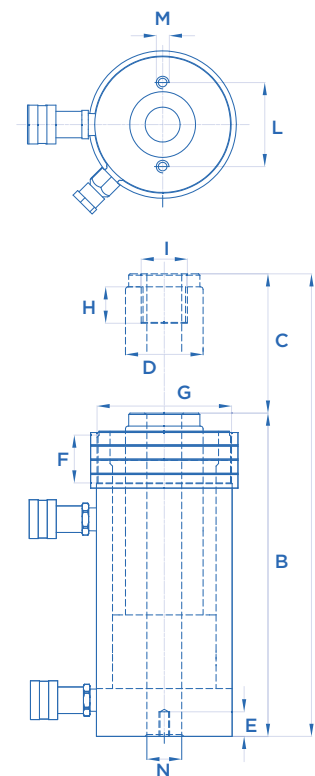

ART.	↑ TON	↓ TON	Pressione Pressure Pression Druck	Capacità olio Oil capacity Capacité huile Ölvolumen	A mm	B mm	C mm	D mm	E mm	F mm	G mm	H mm	I mm	L mm	M mm	N mm	KG
<b>367/H</b>	24	14	700 bar	301,4 cm <sup>3</sup>	330	250	80	60	10	35	M104X2	25	M44X2	67	M6	27	14
<b>367/I</b>	24	14	700 bar	753,6 cm <sup>3</sup>	570	370	200	60	10	35	M104X2	25	M44X2	67	M6	27	24
<b>367/N</b>	37	22	700 bar	471,2 cm <sup>3</sup>	335	255	80	75	18	30	M128X1,5	20	M55X2	88	M10	34	22
<b>367/O</b>	37	22	700 bar	1472,3 cm <sup>3</sup>	675	425	250	75	18	30	M128X1,5	20	M55X2	88	M10	34	34
<b>367/R</b>	48	32	700 bar	671,4 cm <sup>3</sup>	360	270	90	90	20	30	M160X3,5	25	M76X3	98	M12	54	37
<b>367/S</b>	48	32	700 bar	1790,4 cm <sup>3</sup>	660	420	240	90	20	30	M160X3,5	25	M76X3	98	M12	54	45

## POMPE MANUALI COMPLETE DI TUBO FLESSIBILE E GIUNTO RAPIDO

MANUAL PUMPS, SUPPLIED WITH HOSE AND QUICK COUPLING

POMPES MANUELLES, FLEXIBLE ET RACCORD RAPIDE INCLUS

HANDPUMPEN MIT SCHLAUCH AUF SCHNELLKUPPLUNG

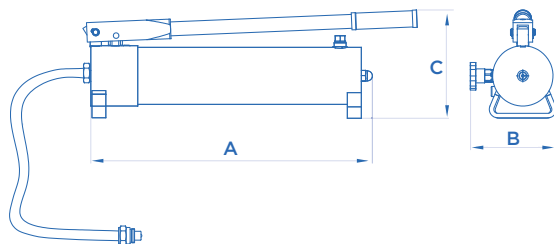

ART. 350/A



ART. 358/C



ART. 358/L

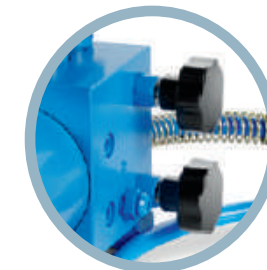

ART.	Tipo pompa Pump type Type de pompe Pumptyp	Valvola a 4 vie 4-way valve Distributeur à 4 voies 4-Wege-Ventil	Pressione Pressure Pression Druck	Portata olio per pompata Oil displacement per stroke Débit par course Fördervolumen pro Kolbenhub	Capacità serbatoio Tank capacity Capacité réservoir Behälterkapazität	A $\longleftrightarrow$ mm	B $\longleftrightarrow$ mm	C $\longleftrightarrow$ mm	KG
350/A	Ad una velocità One-speed Une vitesse Einstufig		700 bar	2,26 cm <sup>3</sup>	1100 cm <sup>3</sup>	510	165	160	9,2
358/A			700 bar	2,26 cm <sup>3</sup>	650 cm <sup>3</sup>	330	140	160	6,5
358/B			700 bar	3,5 cm <sup>3</sup>	2400 cm <sup>3</sup>	500	165	195	13,5
358/K		✓	700 bar	2,26 cm <sup>3</sup>	1000 cm <sup>3</sup>	530	100	150	10
358/C	A due velocità Two-speed Deux vitesses Zweistufig		700 bar	14,13 cm <sup>3</sup>	2400 cm <sup>3</sup>	510	160	200	12,5
358/D			520 bar	26,3 cm <sup>3</sup>	4000 cm <sup>3</sup>	520	200	250	24,5
358/E			520 bar	30,3 cm <sup>3</sup>	7500 cm <sup>3</sup>	565	230	300	40
358/L		✓	700 bar	14,13 cm <sup>3</sup>	2400 cm <sup>3</sup>	560	120	220	21,5

OPTIONAL Pag. 297



# POMPE IDROPNEUMATICHE COMPLETE DI TUBO FLESSIBILE E GIUNTO RAPIDO

AIR-HYDRAULIC PUMPS, SUPPLIED WITH HOSE AND QUICK COUPLING  
 POMPES HYDROPNEUMATIQUES, FLEXIBLE ET RACCORD RAPIDE INCLUS  
 HYDROPNEUMATISCHE PUMPEN MIT SCHLAUCH AUF SCHNELLKUPPLUNG



ART. 357



ART. 357/A



ART. 357/C

## OPTIONAL Pag. 297

ART.	Valvola a 4 vie 4-way valve Distributeur à 4 voies 4-Wege-Ventil	Pressione Pressure Pression Druck	Portata Capacity Capacité Kapazität	Capacità serbatoio Tank capacity Capacité réservoir Behälterkapazität	A mm	B mm	C mm	KG
357		700 bar	0,7 l/min	1100 cm <sup>3</sup>	295	110	170	6,3
357/A		520 bar	1,4 l/min	4500 cm <sup>3</sup>	420	240	220	14
357/B		520 bar	1,4 l/min	8000 cm <sup>3</sup>	420	240	220	19
357/C	✓	700 bar	1,1 l/min	5000 cm <sup>3</sup>	420	240	245	15,5
357/D		700 bar	1,1 l/min	4500 cm <sup>3</sup>	420	240	220	14

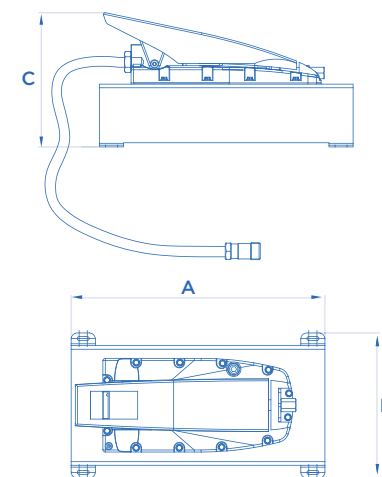

## ACCESSORI EXTRA DOTAZIONE

EXTRA EQUIPMENT • ACCESSOIRES EN OPTION • EXTRA ZUBEHÖR

### MANOMETRI IN GLICERINA

Glycerine-filled pressure gauges  
Manomètres à la glycérine  
Glyzerinmanometer

ART.	Scala Pressure range Pression Druck	Diametro Diameter Diamètre Durchmesser
M/1	0-1000 bar	63 mm
M/2	0-1000 bar	100 mm



### ADATTATORI PER MANOMETRO

Gauge adaptors  
Adaptateurs pour manomètre  
Manometer-Zwischenstück



ART. PM/1 ✓ ART. M/1  
ART. PM/2 ✓ ART. M/2

### PIASTRE DI BASE

Base plates  
Plaques de base  
Zylinderfüße

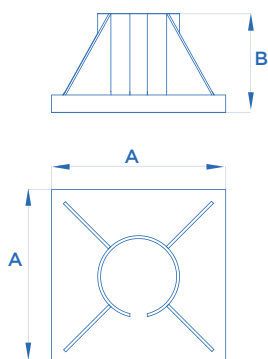

ART.

Compatibilità • Compatibility • Compatibilité • Kompatibilität

A  
mm

B  
mm

BA/1

ART. 359/D • 359/DM • 359/EM • 359/FM • 359/GM • 359/HM

220 155

BA/2

ART. 360/D • 360/DM • 360/EM • 360/FM • 360/GM • 360/HM

220 155

BA/3

ART. 361/D • 361/DM • 361/EM • 361/FM • 361/GM • 361/HM

220 155

BA/4

ART. 362/D • 362/DM • 362/EM • 362/FM • 362/GM • 362/HM

300 170

BA/5

ART. 363/D • 363/DM • 363/EM • 363/FM • 363/GM • 363/HM

300 170



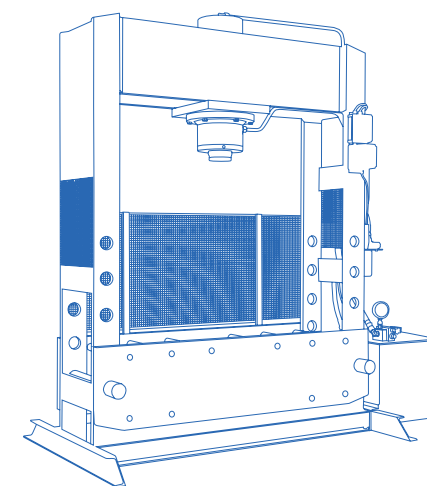

## **PRESSE IDRAULICHE**

HYDRAULIC PRESSES  
PRESSES HYDRAULIQUES  
HYDRAULISCHE PRESSEN

Made in Italy 

**6•10  
TON**



**ART. 152**

# PRESSE IDRAULICHE DA BANCO

HYDRAULIC STAND PRESSES  
PRESSES HYDRAULIQUES D'ETABLI  
HYDRAULISCHE TISCHPRESSEN

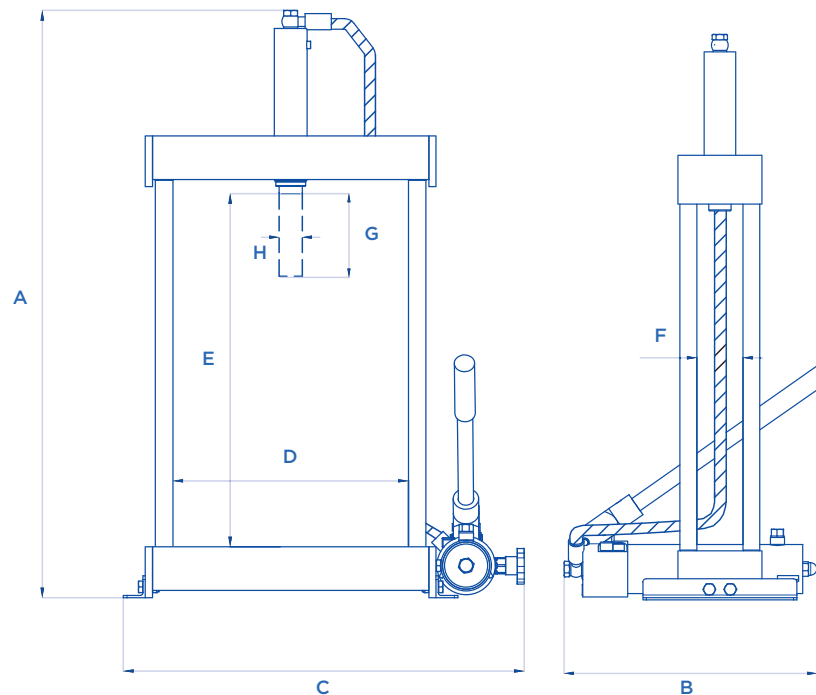

ART.	TON	A mm	B mm	C mm	D mm	E mm	F mm	G mm	H mm	KG
152	6	820	470	550	320	495	67	115	32	43

**OPTIONAL** Pag. 322



**ART. 153**

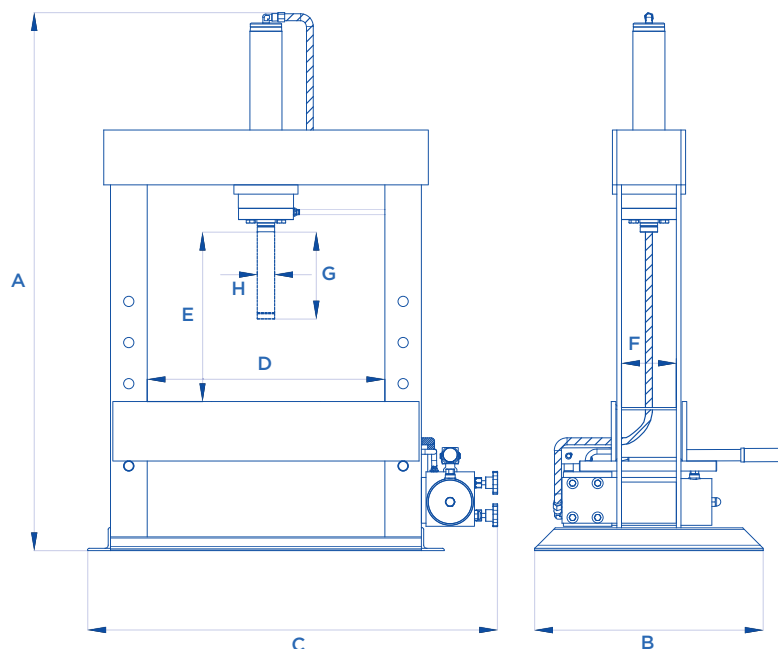

**OPTIONAL** Pag. 322

ART.	TON	A mm	B mm	C mm	D mm	E mm	F mm	G mm	H mm	KG
153	10	1210	500	895	520	370	120	190	40	104

#### TRACCIATO TECNICO COSTRUTTIVO

- Compatta struttura in robusto acciaio saldato.
- Stelo del cilindro in acciaio speciale, trattato e cromato.
- Molla in acciaio inserita nel cilindro per un rapido ritorno dello stelo.
- Pompa a mano a due velocità: rapidità in fase di avvicinamento e precisione in fase di lavoro (153).
- Gestione delle due velocità tramite volanti no posto sulla pompa (153).
- Pompa a mano ad una velocità (152).
- Massima versatilità grazie al bancale ad altezza regolabile (153).
- Piatto cacciaspina e coppia di prismi a V forniti di serie (153).

#### TECHNICAL AND STRUCTURAL LAY-OUT

- Compact and sturdy structure fully made of welded steel.
- Shafts made of specially treated and chromium-plated steel.
- Spring made of steel inside the cylinder for a rapid return of the shaft.
- Two-speed manual pump: fast when approaching and precise when working (153).
- Knob on the pump to control both speeds (153).
- One-speed manual pump (152).
- Maximum versatility thanks to the height-adjustable table (153).
- Supplied with a pin-extracting plate and a pair of V-blocks (153).

#### RELEVÉ TECHNIQUE

- Structure compacte très robuste réalisée exclusivement en acier soudé.
- Tige du cylindre en acier spécial traité et chromé.
- Ressort en acier dans le cylindre pour un retour rapide du vérin.
- Pompe manuelle à deux vitesses: rapidité en phase d'approche et précision en phase de pressage (153).
- Volant à main sur la pompe pour la gestion des deux vitesses (153).
- Pompe manuelle à une vitesse (152).
- Ultra polyvalente grâce au plan de travail réglable en hauteur (153).
- Plateau à trous et couple des prismes à V de série (153).

#### TECHNISCHE UND KONSTRUKTIVE ANGABEN

- Kompakte Struktur, die aus starkem schweißendem Stahl realisiert ist.
- Zylinderkolben aus speziellen Stahl, behandelt sowie auch verchromt.
- Feder aus Stahl, die in den Zylinder einsteckt ist, für einen schnellen Rücklauf des Kolbens.
- Zweistufige Handpumpe: Schnelligkeit während die Annäherungsphase und Exaktheit während die Arbeit (153).
- Führung der zwei Geschwindigkeiten dank einen Handrad auf der Pumpe (153).
- Einstufige Handpumpe (152).
- Maximale Vielseitigkeit dank dem höhenverstellbaren Tisch (153).
- Mit einer Auflageplatte und Doppelprismenblöcke (153).

10•20  
TON



ART. 156



ART. 154/E

## PRESSE IDRAULICHE CON POMPA A MANO

HYDRAULIC PRESSES WITH HAND PUMP

PRESSES HYDRAULIQUES AVEC POMPE MANUELLE

HAND-HYDRAULISCHE PRESSEN

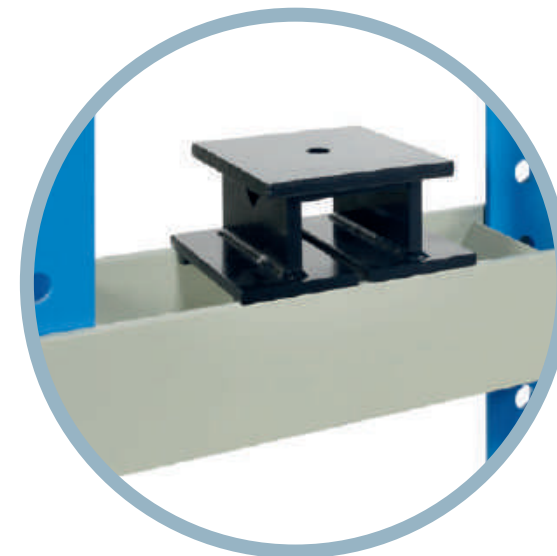

OPTIONAL Pag. 322

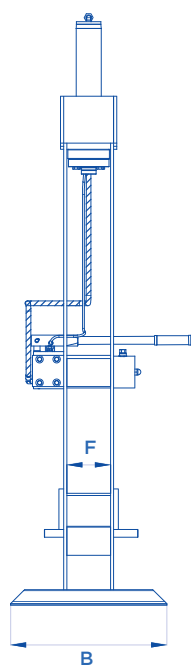
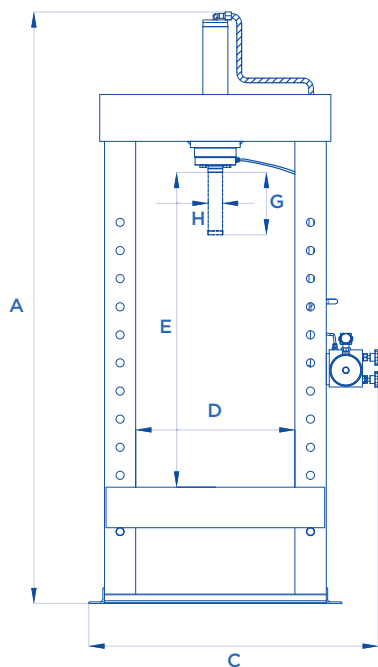
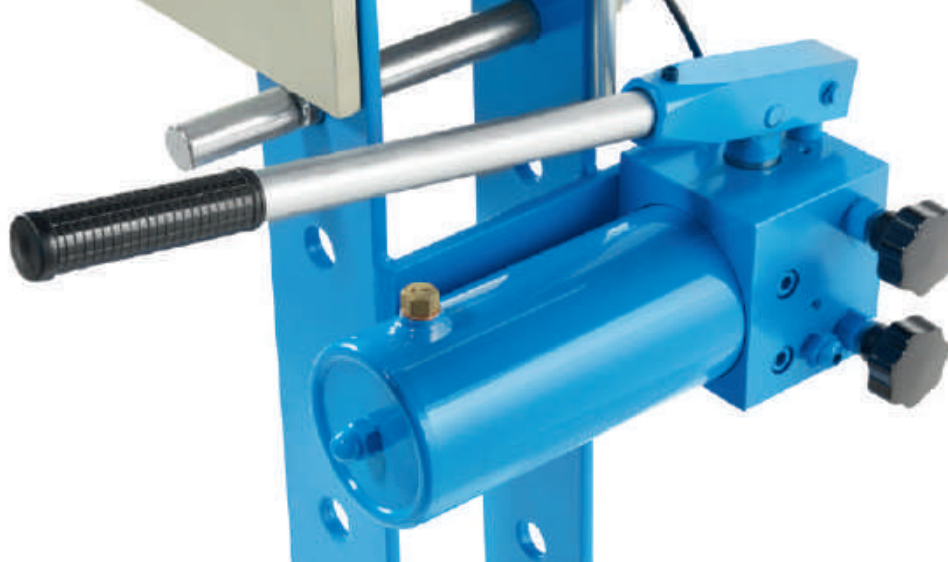

ART.	TON	A mm	B mm	C mm	D mm	E mm	F mm	G mm	H mm	KG
154/E	10	1910	500	870	520	980	120	160	40	94
154	10	1900	500	910	515	980	120	190	40	124
155	15	1930	500	930	510	1020	140	190	40	130
156	20	1960	500	930	510	1020	140	200	50	150

#### TRACCIATO TECNICO COSTRUTTIVO

- Stelo del cilindro in acciaio speciale, trattato e cromato.
- **Molla in acciaio inserita nel cilindro per un rapido ritorno dello stelo.**
- Pompa a mano a due velocità: rapidità in fase di avvicinamento e precisione in fase di lavoro (154 - 155 - 156).
- Gestione delle due velocità tramite volantino posto sulla pompa (154 - 155 - 156).
- Pompa a mano ad una velocità (154/E).
- Massima versatilità grazie al bancale ad altezza regolabile.
- Piatto cacciaspine e coppia di prismi a V forniti di serie (154 - 155 - 156).

#### TECHNICAL AND STRUCTURAL LAY-OUT

- Shafts made of specially treated and chromium-plated steel.
- **Spring made of steel inside the cylinder for a rapid return of the shaft.**
- Two-speed manual pump: fast when approaching and precise when working (154 - 155 - 156).
- Knob on the pump to control both speeds (154 - 155 - 156).
- One-speed manual pump (154/E).
- Maximum versatility thanks to the height-adjustable table.
- Supplied with a pin-extracting plate and a pair of V-blocks (154 - 155 - 156).

#### RELEVÉ TECHNIQUE

- Tige du cylindre en acier spécial traité et chromé.
- **Ressort en acier dans le cylindre pour un rapide retour du tige.**
- Pompe manuelle à deux vitesses : rapidité en phase d'approche et précision en phase de pressage (154 - 155 - 156).
- Volant à main sur la pompe pour la gestion des deux vitesses (154 - 155 - 156).
- Pompe manuelle à une vitesse (154/E).
- Ultra polyvalente grâce au plan de travail réglable en hauteur.
- Plateau à trous et couple des prismes à V de série (154 - 155 - 156).

#### TECHNISCHE UND KONSTRUKTIVE ANGABEN

- Zylinderkolben aus speziellem Stahl, behandelt sowie auch verchromt.
- **Feder aus Stahl, die in den Zylinder einsteckt ist, für einen schnellen Rücklauf des Kolbens.**
- Zweistufige Handpumpe: Schnelligkeit während die Annäherungsphase und Exaktheit während die Arbeit (154 - 155 - 156).
- Führung der zwei Geschwindigkeiten dank einem Handrad auf der Pumpe (154 - 155 - 156).
- Einstufige Handpumpe (154/E).
- Maximale Vielseitigkeit dank dem höhenverstellbaren Tisch.
- Mit einer Auflageplatte und Doppelpismenblocke (154 - 155 - 156).



**30•100  
TON**



**ART. 158**

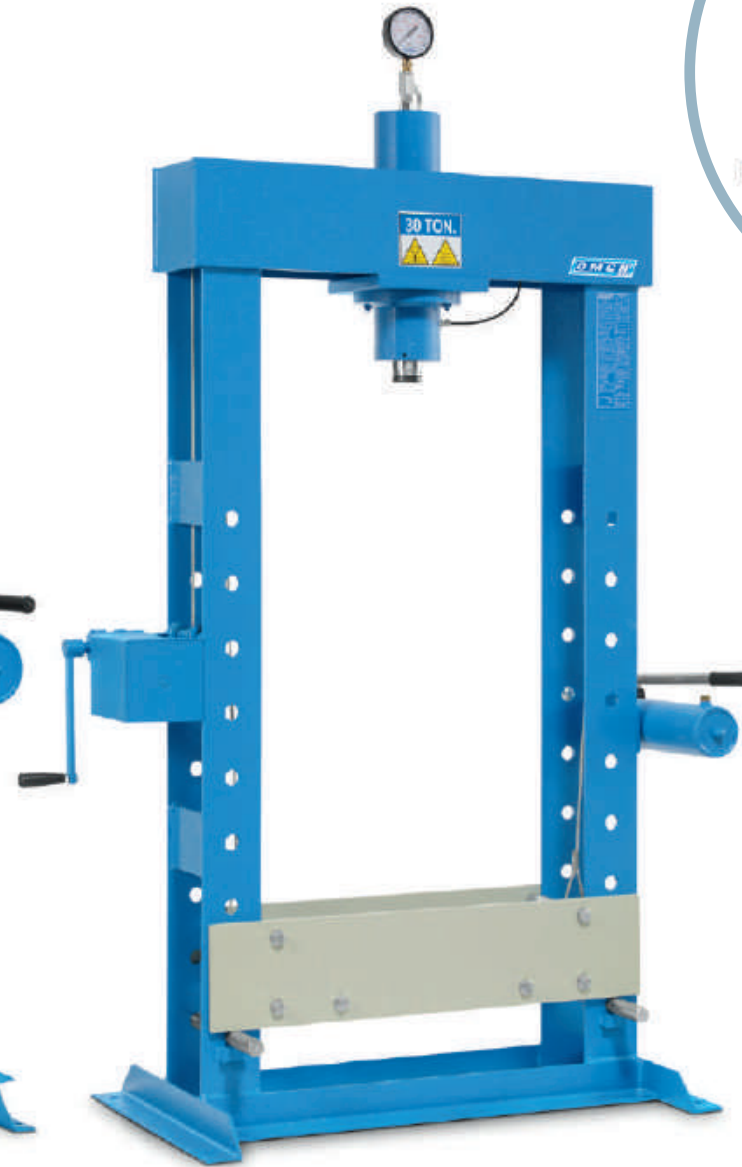

**ART. P30/SA**

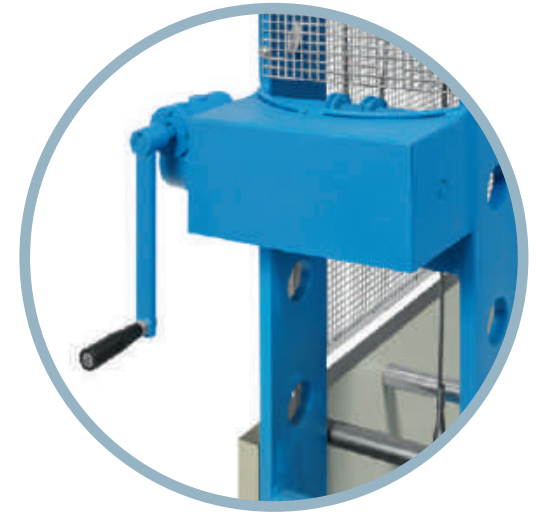

**OPTIONAL** Pag. 322

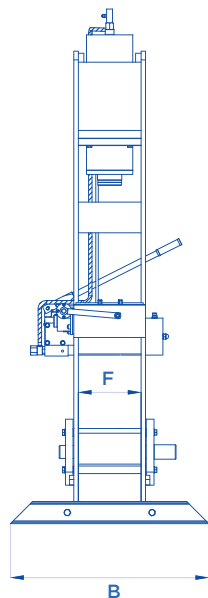
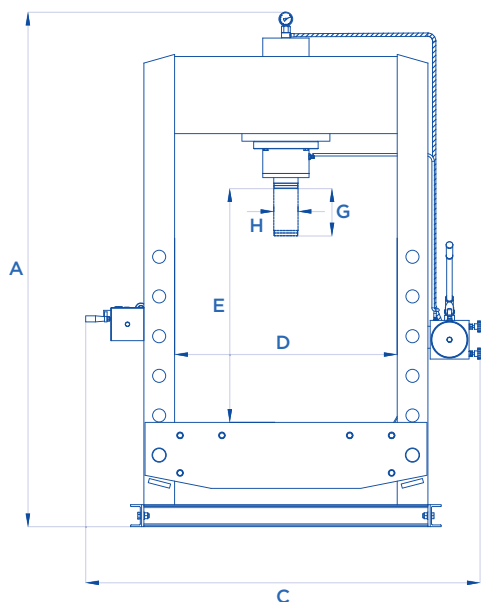
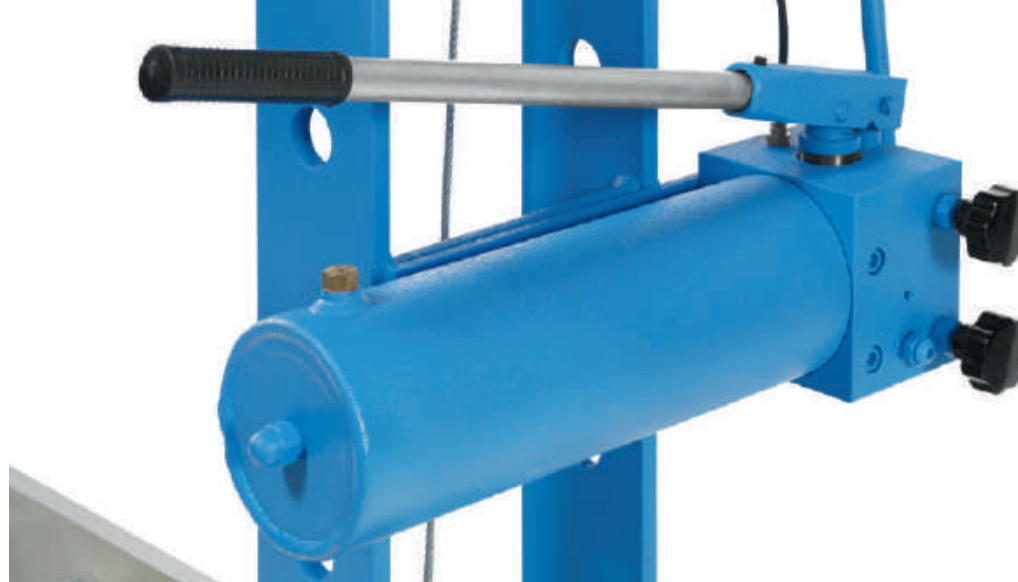

ART.	TON	A mm	B mm	C mm	D mm	E mm	F mm	G mm	H mm	KG
<b>P30/SA</b>	30	2180	600	1300	695	1000	170	190	60	280
<b>157</b>	40	2260	850	1420	770	1135	200	190	60	405
<b>158</b>	50	2260	850	1420	770	1135	210	190	60	455
<b>159</b>	70	2340	900	1580	880	1120	270	210	90	700
<b>160</b>	100	2440	900	1740	1010	1055	285	215	110	960

#### TRACCIATO TECNICO COSTRUTTIVO

- Struttura in robusto acciaio saldato.
- Stelo del cilindro in acciaio speciale, trattato e cromato.
- Molla in acciaio inserita nel cilindro per un rapido ritorno dello stelo.
- **Pompa a mano a due velocità: rapidità in fase di avvicinamento e precisione in fase di lavoro.**
- Gestione delle due velocità tramite volantino posto sulla pompa.
- Complete di argano per poter sollevare il bancale in modo pratico e veloce.
- Manometro di grosso diametro fornito di serie.

#### TECHNICAL AND STRUCTURAL LAY-OUT

- Compact and sturdy structure fully made of welded steel.
- Shafts made of specially treated and chromium-plated steel.
- Spring made of steel inside the cylinder for a rapid return of the shaft.
- **Two-speed manual pump: fast when approaching and precise when working.**
- Knob on the pump to control both speeds.
- Winch to raise easily and quickly the workbench.
- Supplied with a large diameter manometer.

#### RELEVÉ TECHNIQUE

- Structure compacte très robuste réalisée exclusivement en acier soudé.
- Tige du cylindre en acier spécial traité et chromé.
- Ressort en acier dans le cylindre pour un retour rapide du vérin.
- **Pompe manuelle à deux vitesses : rapidité en phase d'approche et précision en phase de pressage.**
- Volant à main sur la pompe pour la gestion des deux vitesses.
- Treuil pour relever le plan de travail rapidement et sans effort.
- Manomètre de gros diamètre de série.

#### TECHNISCHE UND KONSTRUKTIVE ANGABEN

- Struktur aus starkem schweißendem Stahl.
- Zylinderkolben aus speziellen Stahl, behandelt sowie auch verchromt.
- Feder aus Stahl, die in den Zylinder einsteckt, für einen schnellen Rücklauf des Kolbens.
- **Zweistufige Handpumpe: Schnelligkeit während die Annäherungsphase und Exaktheit während die Arbeit.**
- Führung der zwei Geschwindigkeiten dank einen Handrad auf der Pumpe.
- Mit einer Winde, um den Tisch einfach und schnell zu heben.
- Mit einem serienmäßigen Manometer mit einem großen Durchmesser.

**10•50  
TON**

## PRESSE IDRAULICHE CON POMPA IDROPNEUMATICA A PEDALE

HYDRAULIC PRESSES WITH  
HYDROPNEUMATIC FOOT PUMP

PRESSES HYDRAULIQUES AVEC POMPE  
HYDROPNEUMATIQUE A PEDALE

HYDRAULISCHE PRESSEN MIT  
HYDROPNEUMATISCHER FUSSPUMPE

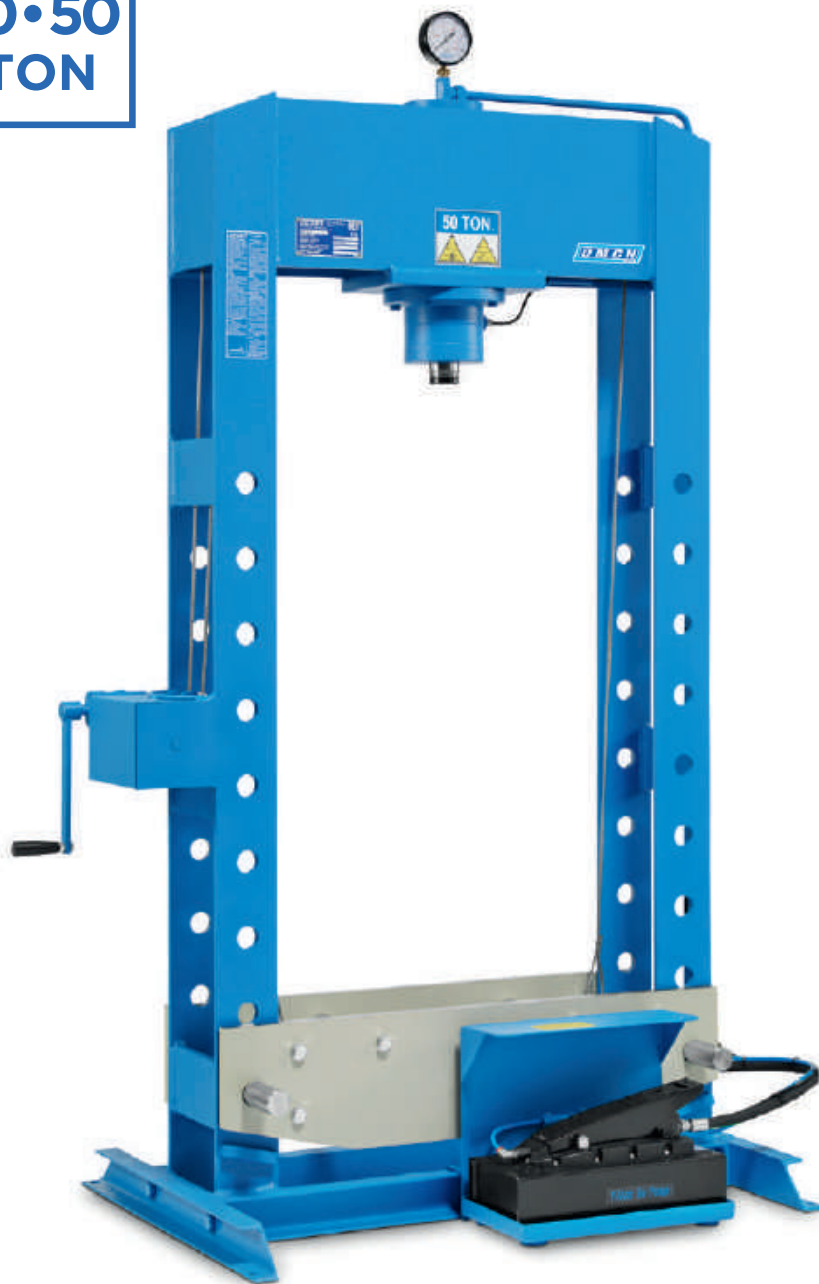

ART. 158/IP



ART. 156/IP

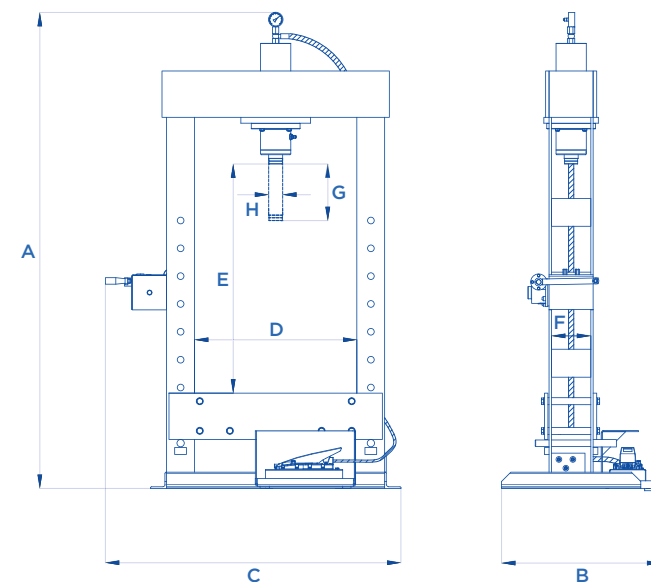

**OPTIONAL** Pag. 322



ART.	TON		 mm/min	 mm	 mm	 mm	 mm	 mm	 mm	 mm	 mm	 KG
<b>154/IP</b>	10	6-8 bar	450	1910	500	780	520	980	120	190	40	124
<b>155/IP</b>	15	6-8 bar	450	1930	500	790	510	1020	140	190	40	130
<b>156/IP</b>	20	6-8 bar	330	1960	500	810	510	1020	140	200	50	150
<b>P30/SAIP</b>	30	6-10 bar	170	2170	600	1270	695	1000	170	190	60	280
<b>157/IP</b>	40	6-10 bar	170	2260	850	1330	770	1135	200	190	60	405
<b>158/IP</b>	50	6-10 bar	120	2260	850	1330	770	1135	210	190	60	445

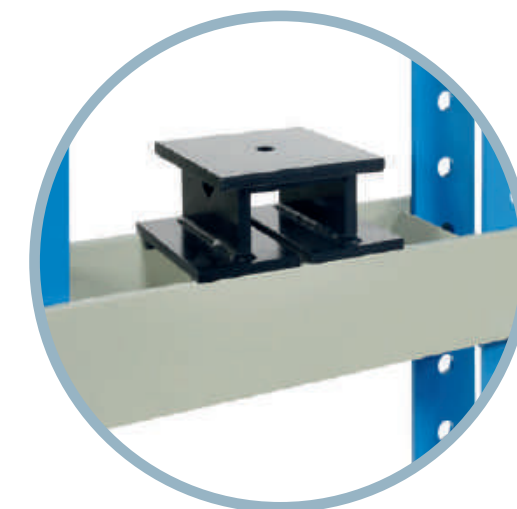

 Velocità stelo • Rod speed • Vitesse du piston • Hub Geschwindigkeit

 Alimentazione pneumatica • Pneumatic feeding • Pression d'alimentation • Benötigter Luftdruck

#### TRACCIATO TECNICO COSTRUTTIVO

- Stelo del cilindro in acciaio speciale, trattato e cromato.
- Molla in acciaio inserita nel cilindro per un rapido ritorno dello stelo.
- **La pompa idropneumatica a pedale consente di lavorare avendo entrambe le mani libere.**
- Massima versatilità grazie al bancale ad altezza regolabile.
- Complete di argano per poter sollevare il bancale in modo pratico e veloce (P30/SAIP - 157/IP - 158/IP).
- Piatto cacciaspina e coppia di prismi a V forniti di serie (154/IP - 155/IP - 156/IP).
- Manometro di grosso diametro fornito di serie (P30/SAIP - 157/IP - 158/IP).

#### TECHNICAL AND STRUCTURAL LAY-OUT

- Shafts of the cylinder of treated and chromium-plated special steel.
- Spring of steel inside the cylinder for a rapid return to the shaft.
- **Hydro-pneumatic foot pump that lets you work with both the hands free.**
- Maximum versatility thanks to the height-adjustable table.
- Winch to easily and quickly lift the working-table (P30/SAIP - 157/IP - 158/IP).
- Pin-extracting plate with a couple of V-blocks (154/IP - 155/IP - 156/IP).
- Big-diameter manometer (P30/SAIP - 157/IP - 158/IP).

#### RELEVÉ TECHNIQUE

- Tige du cylindre en acier spécial traité et chromé.
- Ressort en acier dans le cylindre pour un rapide retour du tige.
- **Pompe hydropneumatique à pédale pour travailler avec toutes les deux mains libres.**
- Ultra polyvalente grâce au plan de travail réglable en hauteur.
- Treuil pour relever le plan de travail rapidement et sans effort (P30/SAIP - 157/IP - 158/IP).
- Plateau à trous et couple des prismes à V de série (154/IP - 155/IP - 156/IP).
- Manomètre de gros diamètre de série (P30/SAIP - 157/IP - 158/IP).

#### TECHNISCHE UND KONSTRUKTIVE ANGABEN

- Zylinderkolben aus speziellen Stahl, behandelt sowie auch verchromt.
- Feder aus Stahl, die in den Zylinder einsteckt ist, für einen schnellen Rücklauf des Kolbens.
- **Fußhydropneumatische Pumpe, die erlaubt Sie mit den beiden Freihände zu arbeiten.**
- Maximale Vielseitigkeit dank dem höhenverstellbaren Tisch.
- Mit einer Winde, um den Tisch einfach und schnell zu heben (P30/SAIP - 157/IP - 158/IP).
- Mit einer Auflageplatte und Doppelpismenblocke (154/IP - 155/IP - 156/IP).
- Mit einem serienmäßigen Manometer mit einem großen Durchmesser (P30/SAIP - 157/IP - 158/IP).

**10-30  
TON**

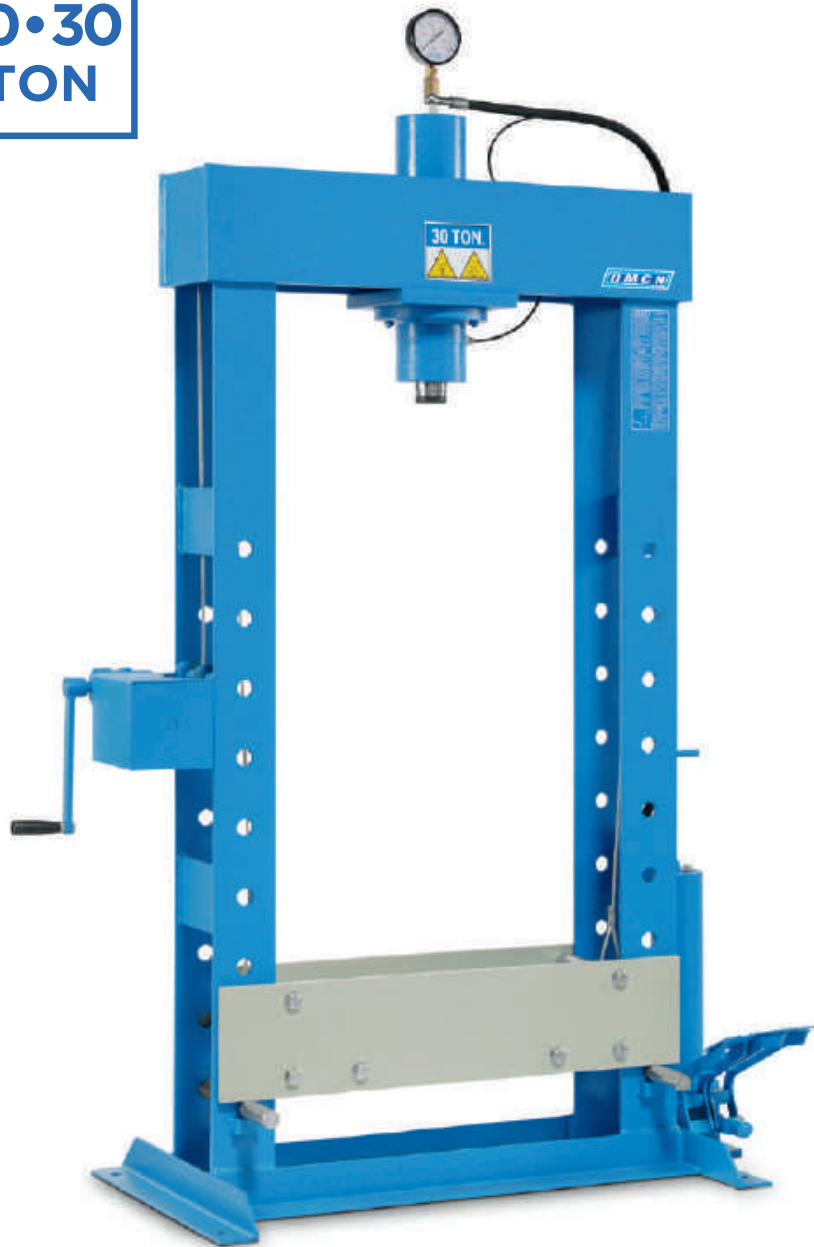

ART. P30/SAP



ART. 155/P

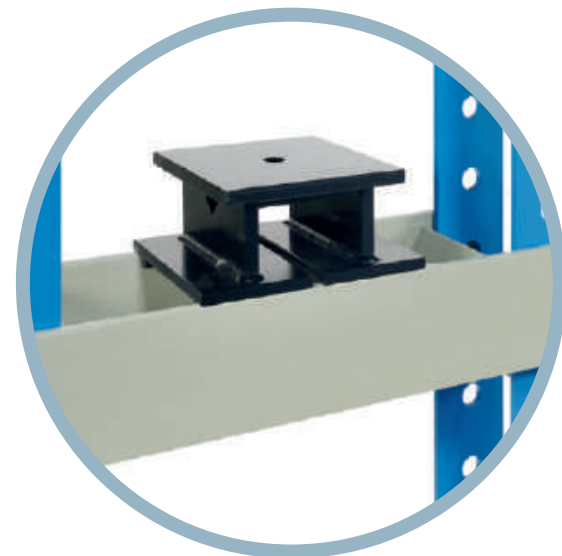

## **PRESE IDRAULICHE CON POMPA A PEDALE**

HYDRAULIC PRESSES WITH FOOT PUMP  
PRESSES HYDRAULIQUES AVEC POMPE A PEDALE  
HYDRAULISCHE PRESSEN MIT FUSSPUMPE

**OPTIONAL** Pag. 322

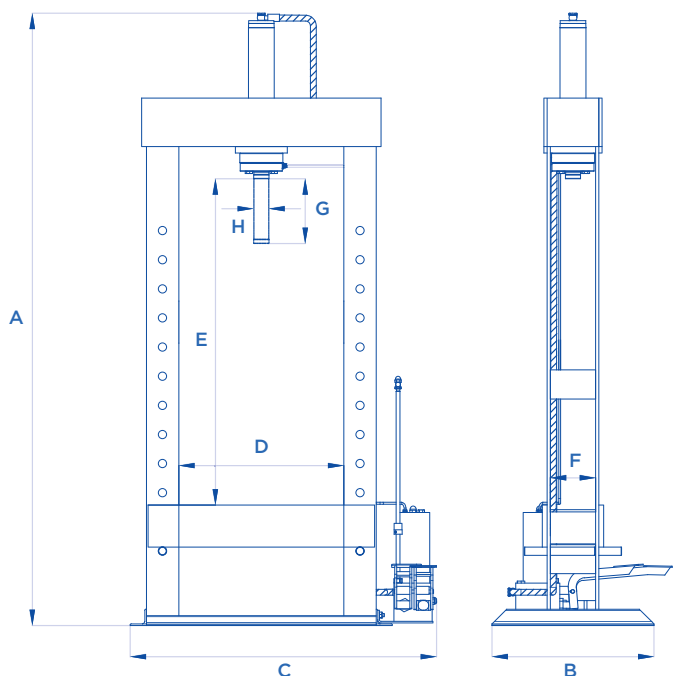
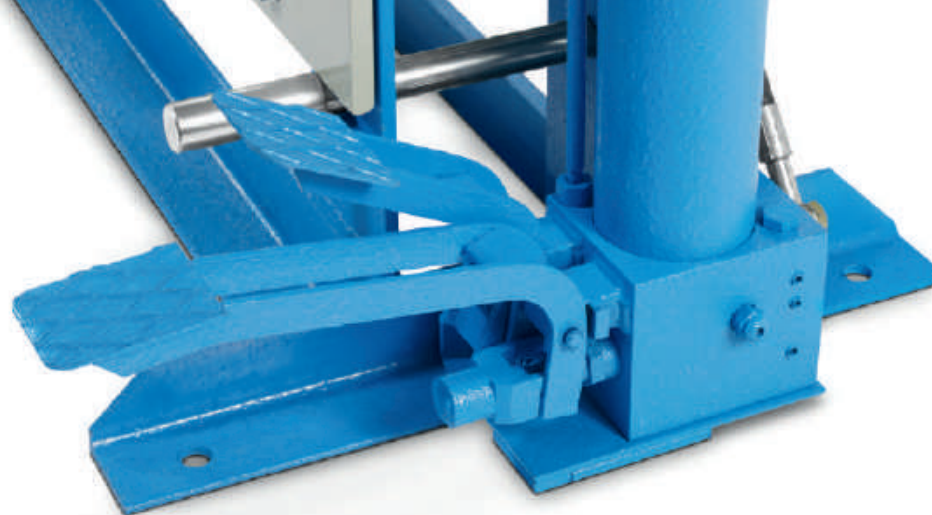

ART.	TON	A mm	B mm	C mm	D mm	E mm	F mm	G mm	H mm	KG
154/P	10	1910	500	910	520	980	120	190	40	124
155/P	15	1930	500	930	510	1020	140	190	40	130
156/P	20	1960	500	930	510	1020	140	200	50	150
P30/SAP	30	2170	600	1300	695	1000	170	190	60	280

#### TRACCIATO TECNICO COSTRUTTIVO

- Stelo del cilindro in acciaio speciale, trattato e cromato.
- Molla in acciaio inserita nel cilindro per un rapido ritorno dello stelo.
- La pompa a pedale consente di lavorare avendo entrambe le mani libere.
- **Pompa a due velocità: rapidità in fase di avvicinamento e precisione in fase di lavoro.**
- Massima versatilità grazie al bancale ad altezza regolabile.
- Completa di argano per poter sollevare il bancale in modo pratico e veloce (P30/SAP).
- Piatto cacciaspina e coppia di prismi a V forniti di serie (154/P - 155/P - 156/P).
- Manometro di grosso diametro fornito di serie (P30/SAP).

#### TECHNICAL AND STRUCTURAL LAY-OUT

- Shafts of the cylinder of treated and chromium-plated special steel.
- Spring of steel inside the cylinder for a rapid return to the shaft.
- Foot pump that lets you work with both the hands free.
- **Two-speed pump: rapidity during the approaching phase and precision during the working phases.**
- Maximum versatility thanks to the height-adjustable table.
- Winch to easily and quickly lift the working-table (P30/SAP).
- Pin-extracting plate with a couple of V-blocks (154/P - 155/P - 156/P).
- Big-diameter manometer (P30/SAP).

#### RELEVÉ TECHNIQUE

- Tige du cylindre en acier spécial traité et chromé.
- Ressort en acier dans le cylindre pour un rapide retour du tige.
- Pompe à pédale pour travailler avec toutes les deux mains libres.
- **Pompe à deux vitesses : rapidité pendant la phase d'approche et précision pendant le travail.**
- Ultra polyvalente grâce au plan de travail réglable en hauteur
- Treuil pour relever le plan de travail rapidement et sans effort (P30/SAP).
- Plateau à trous et couple des prismes à V de série (154/P - 155/P - 156/P).
- Manomètre de gros diamètre de série (P30/SAP).

#### TECHNISCHE UND KONSTRUKTIVE ANGABEN

- Zylinderkolben aus speziellen Stahl, behandelt sowie auch verchromt.
- Feder aus Stahl, die in den Zylinder einsteckt, für einen schnellen Rücklauf des Kolbens.
- Fußpumpe, die erlaubt Sie mit den beiden Freihände zu arbeiten.
- **Zweistufige Pumpe: Schnelligkeit während die Annäherungsphase und Exaktheit während die Arbeit.**
- Maximale Vielseitigkeit dank dem höhenverstellbaren Tisch.
- Mit einer Winde, um den Tisch einfach und schnell zu heben (P30/SAP).
- Mit einer Auflageplatte und Doppelprismenblocke (154/P - 155/P - 156/P).
- Mit einem serienmäßigen Manometer mit einem großen Durchmesser (P30/SAP).

**10•100  
TON**

**ML  
LINE**

**PRESSE ELETTROIDRAULICHE**

ELECTROHYDRAULIC PRESSES  
PRESSES ELECTROHYDRAULIQUES  
ELEKTROHYDRAULISCHE PRESSEN



ART. 156/ML



ART. 164

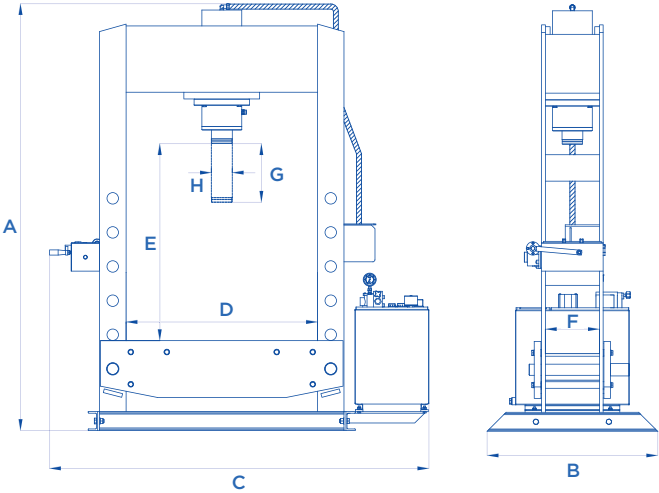

**OPTIONAL** Pag. 322



ART.	TON	 mm/min	 mm	 mm	 mm	 mm	 mm	 mm	 mm	 mm		
<b>154/ML</b>	10	570	1910	500	1100	520	980	120	260	40	1,5 kw	174
<b>156/ML</b>	20	300	1960	500	1110	510	1000	140	285	50	1,5 kw	190
<b>P30/ML</b>	30	300	2020	600	1600	695	1000	170	260	60	1,5 kw	320
<b>161</b>	40	300	2130	850	1575	770	1135	200	260	60	1,5 kw	440
<b>162</b>	50	210	2130	850	1570	770	1135	210	260	60	1,5 kw	480
<b>163</b>	70	260	2210	900	1755	880	1120	270	310	90	3 kw	740
<b>164</b>	100	180	2310	900	1930	1010	1055	285	310	110	3 kw	1000

 Velocità stelo • Rod speed • Vitesse du piston • Hub Geschwindigkeit  Potenza motore • Motor power • Puissance moteur • Motorleistung

#### TRACCIATO TECNICO COSTRUTTIVO

- Stelo del cilindro in acciaio speciale, trattato e cromato.
- **Centralina motorizzata ad una velocità.**
- Azionamento tramite distributore a leva a 3 posizioni. Questa soluzione permette di avere una mano libera per lavorare.
- Dotate di valvola di taratura per regolare la potenza in base alla lavorazione da eseguire.
- Massima versatilità grazie al bancale ad altezza regolabile.
- Complete di argano per poter sollevare il bancale in modo pratico e veloce (escluso 154/ML - 156/ML).
- Manometro fornito di serie.

#### TECHNICAL AND STRUCTURAL LAY-OUT

- Shafts of the cylinder made of treated and chromium-plated special steel.
- **Motorized one-speed control unit.**
- Start-up by means of a 3-position lever distributor. This solution allows you to have one hand free to work.
- With a control valve to set the power according to the work you have to do.
- Maximum versatility thanks to the height-adjustable table.
- Winch to easily and quickly lift the working-table (except for art. 154/ML - 156/ML).
- Supplied with a manometer.

#### RELEVÉ TECHNIQUE

- Tige du cylindre en acier spécial traité et chromé.
- **Groupe hydraulique motorisé à une vitesse.**
- Actionnement par distributeur à levier à 3 positions. Cette solution permet d'avoir une main libre pour travailler.
- Avec soupape de calibrage pour régler la puissance par rapport au travail à faire.
- Ultra polyvalent grâce au plan de travail réglable en hauteur.
- Treuil pour relever le plan de travail rapidement et sans effort (sauf art. 154/ML - 156/ML).
- Manomètre de série.

#### TECHNISCHE UND KONSTRUKTIVE ANGABEN

- Zylinderkolben aus speziellen Stahl, behandelt sowie auch verchromt.
- **Einstufiges motorisiertes Steuergerät.**
- Antrieb mittels einem Hebel-Dreiwegeverteiler.
- Diese Lösung erlaubt Sie einem Freihand zu haben, um zu arbeiten.
- Mit einem Eichventil, um die Kraft der Maschine gemäß die Arbeitstypologie zu regeln.
- Maximale Vielseitigkeit dank dem höhenverstellbaren Tisch.
- Mit einer Winde, um den Tisch einfach und schnell zu heben (nicht für art. 154/ML - 156/ML).
- Serienmäßiger Manometer.



20•150  
TON

W  
LINE



ART. 164/W



ART. P30/W

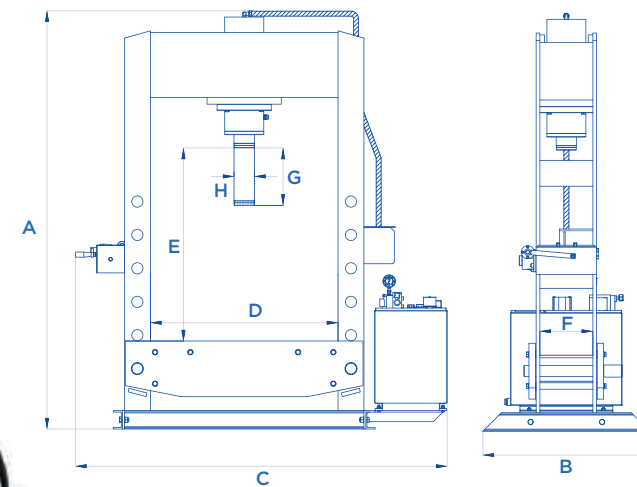

OPTIONAL Pag. 322



ART.	TON	 mm/min	 mm/min	 mm	 mm	 mm	 mm	 mm	 mm	 mm	 mm		 KG
<b>156/W</b>	20	450		1960	500	1110	510	1000	140	285	50	1,5 kw	200
<b>P30/W</b>	30	575		2020	600	1600	695	1000	170	260	60	3 kw	330
<b>161/W</b>	40	575		2130	850	1650	775	1135	195	260	60	3 kw	470
<b>162/W</b>	50	600	215	2130	850	1650	775	1135	205	260	60	1,5 kw	530
<b>163/W</b>	70	595	260	2210	900	1755	880	1120	265	310	90	3 kw	800
<b>164/W</b>	100	570	180	2310	900	1930	1010	1055	280	310	110	3 kw	1050
<b>164/WS</b>	100	570	180	2470	1300	2320	1520	1065	360	310	110	3 kw	1500
<b>204/W</b>	150	600	120	2600	1300	2470	1520	1018	410	400	140	4 kw	2200
<b>204/WE</b>	150	600	120	2600	1300	1970	1020	1035	410	400	140	4 kw	1870

-  Potenza motore • Motor power • Puissance moteur • Motorleistung  Velocità lavoro • Working speed • Vitesse travail • Arbeitsgeschwindigkeit
-  Velocità avvicinamento • Approaching speed • Vitesse approche • Vorlaufgeschwindigkeit

#### TRACCIATO TECNICO COSTRUTTIVO

- Stelo del cilindro in acciaio speciale, trattato e cromato.
- Centralina motorizzata a due velocità ad inserimento automatico (escluso 156/W - P30/W - 161/W).
- **Azionamento tramite distributore a leva a 3 posizioni. Questa soluzione permette di avere una mano libera per lavorare.**
- Dotate di valvola di taratura per regolare la potenza in base alla lavorazione da eseguire.
- Massima versatilità grazie al bancale ad altezza regolabile.
- Sollevamento del bancale tramite apposito argano (P30/W - 161/W - 162/W - 163/W - 164/W).
- Sollevamento del bancale tramite asta (164/WS - 204/W - 204/WE).
- Manometro fornito di serie.

#### TECHNICAL AND STRUCTURAL LAY-OUT

- Shaft of the cylinder made of treated and chromium-plated special steel.
- Motorized 2-speeds control unit with automatic insertion (except art. 156/W - P30/W - 161/W).
- **Start-up by means of a 3-position lever distributor. This solution allows you to have one hand free to work.**
- With a control valve to set the power according to the work you have to do.
- Maximum versatility thanks to the height-adjustable table.
- Winch to raise easily and quickly the workbench (P30/W - 161/W - 162/W - 163/W - 164/W).
- Rod to raise the workbench (164/WS - 204/W - 204/WE).
- Supplied with a manometer.

#### RELEVÉ TECHNIQUE

- Tige du cylindre en acier spécial traité et chromé.
- Groupe hydraulique motorisé à deux vitesses à insertion automatique (sauf pour les art. 156/W - P30/W - 161/W).
- **Actionnement par distributeur à levier à 3 positions. Cette solution permet d'avoir une main libre pour travailler.**
- Soupape de calibrage pour régler la puissance par rapport au travail à faire.
- Ultra polyvalente grâce au plan de travail réglable en hauteur.
- Relevage du plan de travail par treuil (P30/W - 161/W - 162/W - 163/W - 164/W).
- Relevage du plan de travail par barre (164/WS - 204/W - 204/WE).
- Manomètre de série.

#### TECHNISCHE UND KONSTRUKTIVE ANGABEN

- Zylinderkolben aus speziellen Stahl, behandelt sowie auch verchromt.
- Zweistufiges motorisiertes Steuergerät mit automatischen Einstecken (nicht für Art. 156/W - P30/W - 161/W).
- **Antrieb mittels einem Hebel-Dreivegeverteiler. Diese Lösung erlaubt Sie einem Freihand zu haben, um zu arbeiten.**
- Mit einem Eichventil, um die Kraft der gemäß die Arbeitstypologie zu regeln.
- Maximale Vielseitigkeit dank dem höhenverstellbaren Tisch.
- Hebung dem Tisch mittels einer Winde (P30/W - 161/W - 162/W - 163/W - 164/W).
- Hebung dem Tisch mittels einer Stange (164/WS - 204/W - 204/WE).
- Serienmäßiger Manometer.

**10•150  
TON**

**R  
LINE**

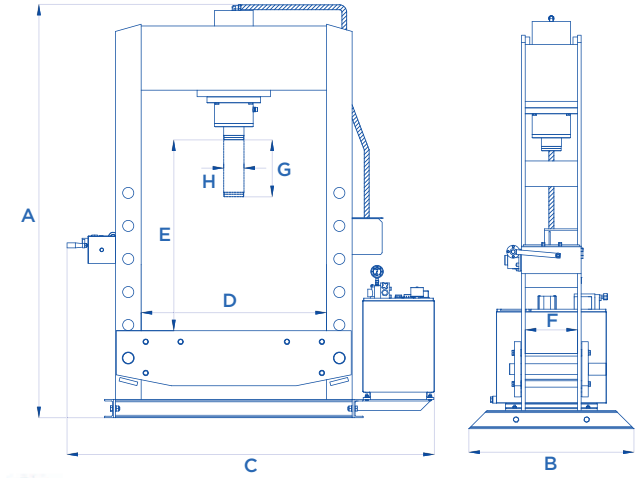



ART. 204/R



ART. 164/R



ART.	TON	 mm/min	 mm/min	 mm	 mm	 mm	 mm	 mm	 mm	 mm	 mm		
<b>154/MR</b>	10	1750	350	1910	500	1100	520	980	120	260	40	0,75 kw	194
<b>156/MR</b>	20	1100	300	1960	500	1110	510	1000	140	285	50	0,75 kw	208
<b>P30/MR</b>	30	1550	300	2020	600	1600	695	1000	170	260	60	1,5 kw	338
<b>161/R</b>	40	1530	300	2130	850	1650	775	1135	195	260	60	1,5 kw	530
<b>162/R</b>	50	1540	210	2130	850	1650	775	1135	205	260	60	1,5 kw	560
<b>163/R</b>	70	1600	260	2210	900	1755	880	1120	265	310	90	3 kw	850
<b>164/R</b>	100	1600	180	2310	900	1930	1010	1055	280	310	110	3 kw	1100
<b>164/RS</b>	100	1600	180	2470	1300	2320	1520	1065	360	310	110	3 kw	1500
<b>204/R</b>	150	1600	120	2600	1300	2470	1520	1018	410	400	140	4 kw	2200
<b>204/RE</b>	150	1600	120	2600	1300	1970	1020	1035	410	400	140	4 kw	1870

 Potenza motore • Motor power • Puissance moteur • Motorleistung  Velocità lavoro • Working speed • Vitesse travail • Arbeitsgeschwindigkeit  
 Velocità avvicinamento • Approaching speed • Vitesse approche • Vorlaufgeschwindigkeit

## TRACCIATO TECNICO COSTRUTTIVO

- Stelo del cilindro in acciaio speciale, trattato e cromato.
- Centralina motorizzata a due velocità ad inserimento automatico.
- **Funzionamento tramite distributore a leva e pulsante sul quadro da azionare contemporaneamente.**
- Complete di pannelli protettivi posteriore e laterali in acciaio zincato.
- Dotate di valvola di taratura per regolare la potenza in base alla lavorazione da eseguire.
- Massima versatilità grazie al bancale ad altezza regolabile.
- Sollevamento del bancale tramite apposito argano (P30/MR - 161/R - 162/R - 163/R - 164/R).
- Sollevamento del bancale tramite asta (164/RS - 204/R - 204/RE).
- Manometro fornito di serie.

## TECHNICAL AND STRUCTURAL LAY-OUT

- Shaft of the cylinder made of treated and chromium-plated special steel.
- Motorized 2-speeds control unit with automatic insertion.
- **Operated by lever distributor and button on the control box to be activated simultaneously.**
- Protection rear and side panels made of zinc-plated steel.
- Calibrating valve to control the power according to the work you have to do.
- Maximum versatility thanks to the height-adjustable table.
- Winch to raise workbench (P30/MR - 161/R - 162/R - 163/R - 164/R).
- Shaft to raise workbench (164/RS - 204/R - 204/RE).
- Supplied with standard manometer.

## RELEVÉ TECHNIQUE

- Tige du cylindre en acier spécial traité et chromé.
- Groupe hydraulique de commande motorisé à deux vitesses à insertion automatique.
- **Fonctionnement par distributeur à levier et bouton sur le boîtier électrique à activer en simultanée.**
- Panneaux de protection arrière et sur les côtés en acier galvanisé.
- Soupape de calibrage pour régler la puissance par rapport au travail à faire.
- Ultra polyvalence grâce au plan de travail réglable en hauteur.
- Relevage du plan de travail par treuil (P30/MR - 161/R - 162/R - 163/R - 164/R).
- Relevage du plan de travail par barre (164/RS - 204/R - 204/RE).
- Manomètre de série.

## TECHNISCHE UND KONSTRUKTIVE ANGABEN

- Zylinderkolben aus speziellen Stahl, behandelt sowie auch verchromt.
- Zweistufiges motorisiertes Steuergerät mit automatischen Einstecken.
- **Betrieb mittels einem Hebelverteiler und einem Druckknopf auf die Schaltkaste, die gleichzeitig geschaltet sein müssen.**
- Mit hinter- und seitlich Schutztafel aus verzinktem Stahl.
- Mit einem Eichventil, um die Kraft der Maschine gemäß die Arbeitstypologie zu regeln.
- Maximale Vielseitigkeit dank dem höhenverstellbaren Tisch.
- Hebung dem Tisch mittels einer Winde (P30/MR - 161/R - 162/R - 163/R - 164/R).
- Hebung dem Tisch mittels einer Stange (164/RS - 204/R - 204/RE).
- Serienmäßiger Manometer.

**200•300  
TON**

**HEAVY  
DUTY**

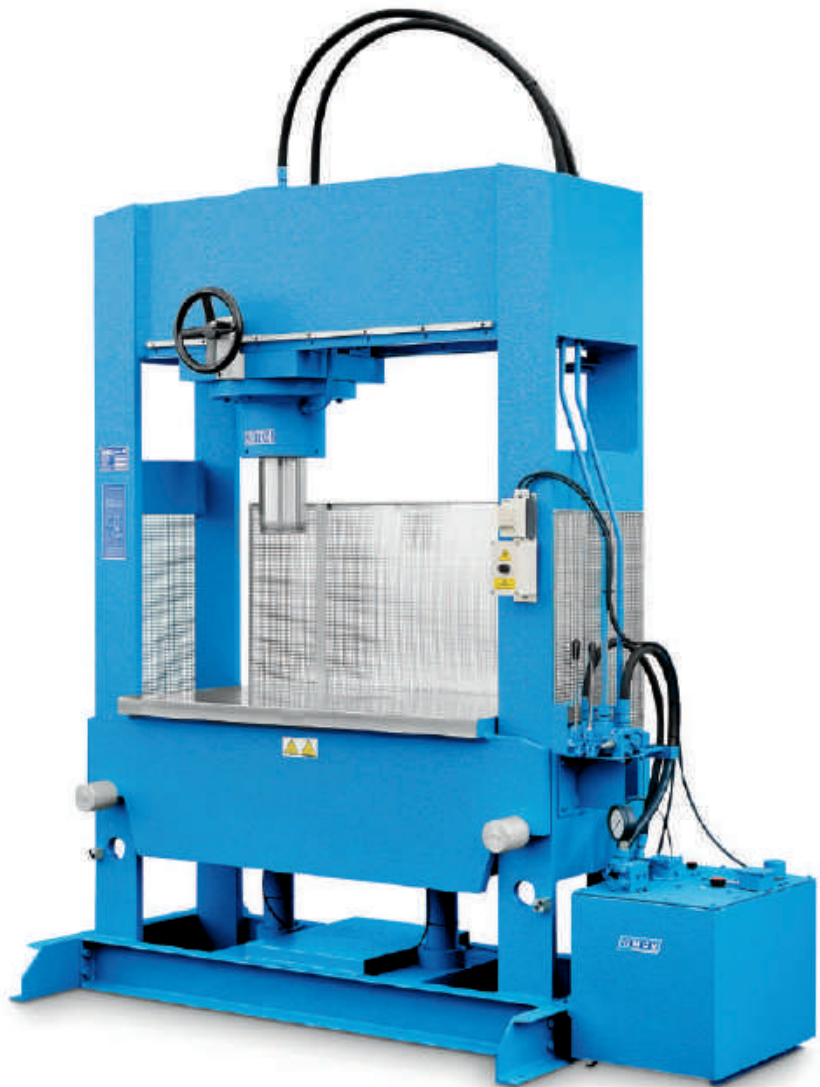

ART. 205/R+022/C

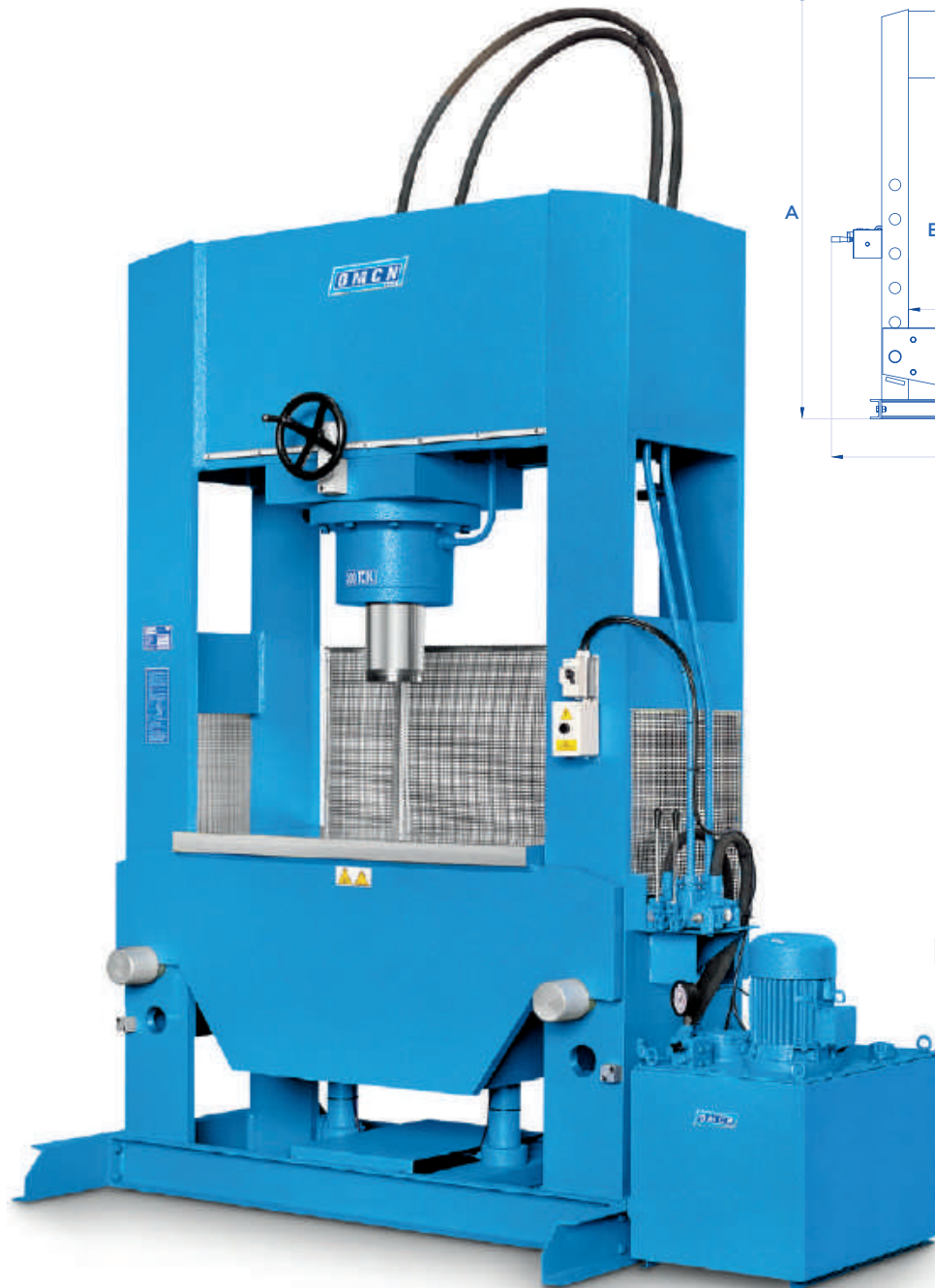

ART. 280/R+022/D

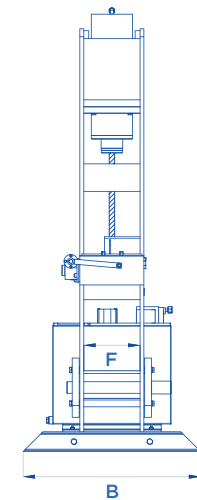
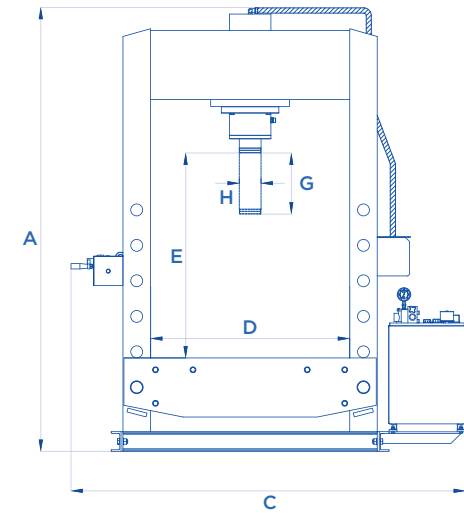

**OPTIONAL** Pag. 322

ART.	TON	 mm/min	 mm/min	 mm	 mm	 mm	 mm	 mm	 mm	 mm	 mm		
<b>205/R</b>	200	1300	95	2995	1310	2600	1520	1020	520	520	170	4 kw	4150
<b>205/W</b>	200	600	95	2995	1310	2600	1520	1020	520	520	170	4 kw	4150
<b>280/R</b>	300	1000	95	3415	1700	2900	1500	960	640	500	210	5,5 kw	8200
<b>280/W</b>	300	600	95	3415	1700	2900	1500	960	640	500	210	5,5 kw	8200

-  Potenza motore • Motor power • Puissance moteur • Motorleistung
-  Velocità lavoro • Working speed • Vitesse travail • Arbeitsgeschwindigkeit
-  Velocità avvicinamento • Approaching speed • Vitesse approche • Vorlaufgeschwindigkeit

**TRACCIATO TECNICO COSTRUTTIVO**

- Stelo del cilindro in acciaio speciale, trattato e cromato.
- Centralina motorizzata a due velocità ad inserimento automatico.
- Funzionamento tramite distributore a leva e pulsante sul quadro da azionare contemporaneamente (205/R - 280/R).
- Azionamento tramite distributore a leva a 3 posizioni. Questa soluzione permette di avere una mano libera per lavorare (205/W - 280/W).
- Complete di pannelli protettivi posteriore e laterali in acciaio zincato (205/R - 280/R).
- Dotate di valvola di taratura per regolare la potenza in base alla lavorazione da eseguire.
- **Sollevamento del bancale tramite due cilindri idraulici azionabili tramite apposita leva.**
- Complete di piano di lavoro fresato.

**TECHNICAL AND STRUCTURAL LAY-OUT**

- Shafts of treated and chromium-plated special steel.
- Motorized 2-speeds control unit with automatic insertion.
- Operation by lever distributor and a button on the control box to be activated simultaneously (205/R - 280/R).
- Start-up by means of a 3-position lever distributor. This solution allows you to have one hand free to work (205/W - 280/W).
- Protection rear and lateral panels made of zinc-plated steel (205/R - 280/R).
- Calibrating valve to set the power according to the work you have to do.
- **Two hydraulic cylinders operated by a lever to raise the workbench.**
- Supplied with a milled working-table.

**RELEVÉ TECHNIQUE**

- Tige du cylindre en acier spécial traité et chromé.
- Groupe hydraulique motorisé à deux vitesses à insertion automatique.
- Fonctionnement par distributeur à levier et bouton sur le cadre à activer en simultanée (205/R - 280/R).
- Actionnement par distributeur à levier à 3 positions. Cette solution permet d'avoir une main libre pendant le travail (205/W - 280/W).
- Panneaux de protection arrière et sur les côtés en acier galvanisé (205/R - 280/R).
- Soupape de calibrage pour régler la puissance par rapport au travail à faire.
- **Relevage du plan de travail au moyen de deux vérins hydrauliques actionnés par levier.**
- Livré avec un plateau fraisé.

**TECHNISCHE UND KONSTRUKTIVE ANGABEN**

- Zylinderkolben aus speziellen Stahl, behandelt sowie auch verchromt.
- Zweistufiges motorisiertes Steuergerät mit automatischen Einstecken.
- Betrieb mittels einem Hebelverteiler und einem Druckknopf auf die Schaltkaste, die gleichzeitig geschaltet sein müssen (205/R - 280/R).
- Antrieb mittels einem Hebel-Dreiwegeverteiler.
- Diese Lösung erlaubt Sie einem Freihand zu haben, um zu arbeiten (205/W - 280/W).
- Mit hinter- und seitlich Schutztafel aus verzinktem Stahl (205/R - 280/R).
- Mit einem Eichventil, um die Kraft der Maschine gemäß die Arbeitstypologie zu regeln.
- **Hebung dem Tisch mittels zwei hydraulischer Zylindern, die mittels des geeigneten Hebels schaltbar sind.**
- Mit einem gefrästem Tisch

**100•150  
TON**

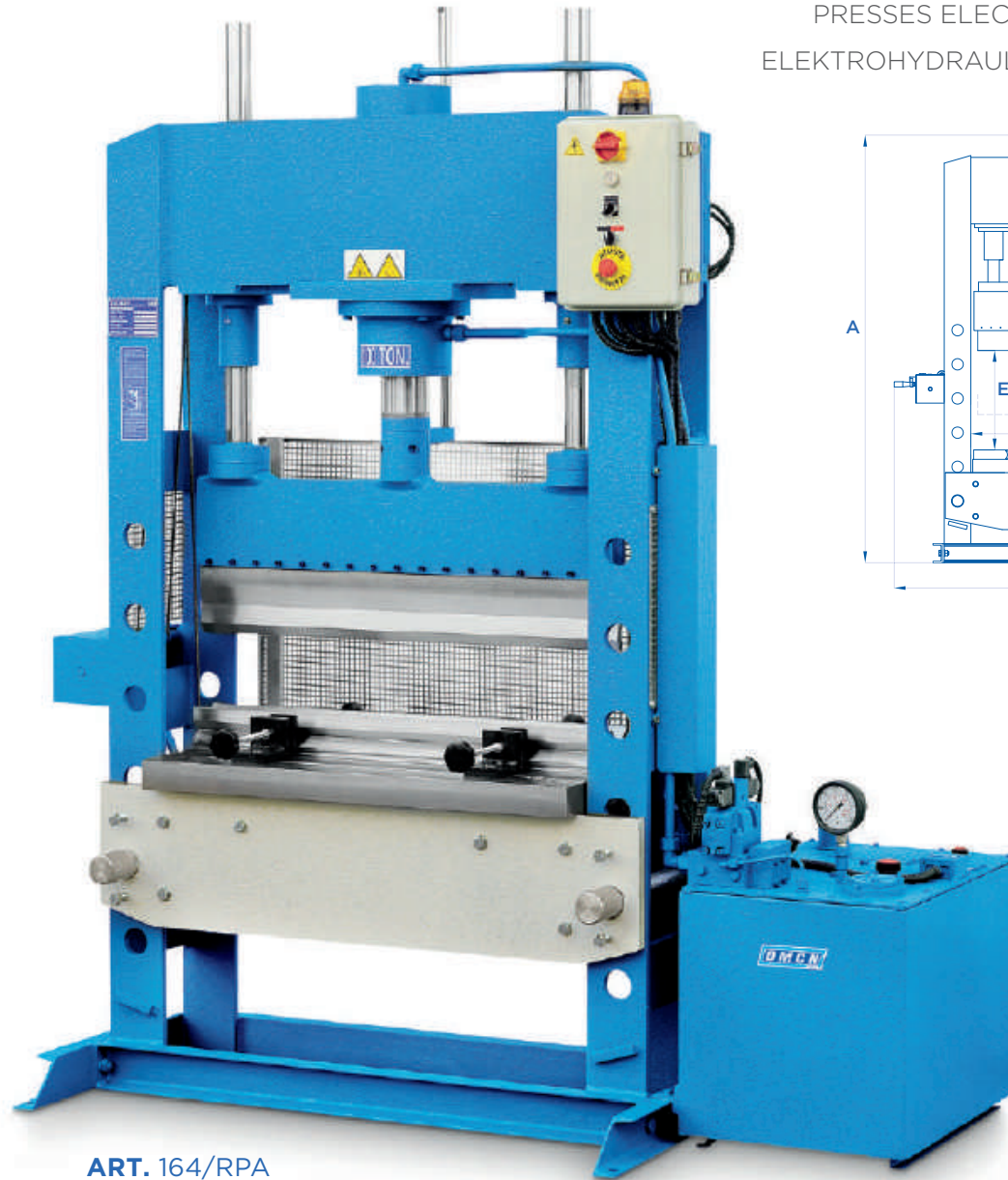
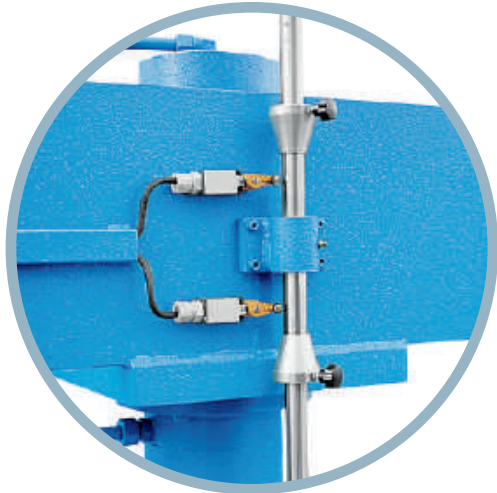

ART. 164/RPA

# PRESSE ELETTRIDRAULICHE PER PIEGATURE

ELECTROHYDRAULIC PRESSES FOR BENDING  
 PRESSES ELECTROHYDRAULIQUES POUR PLIAGE  
 ELEKTROHYDRAULISCHE PRESSEN FÜR BLECHBIEGE

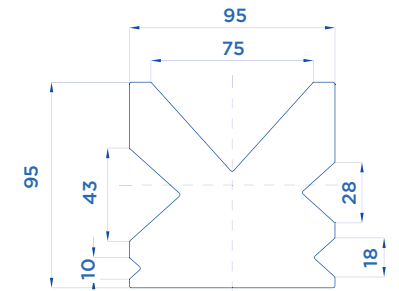
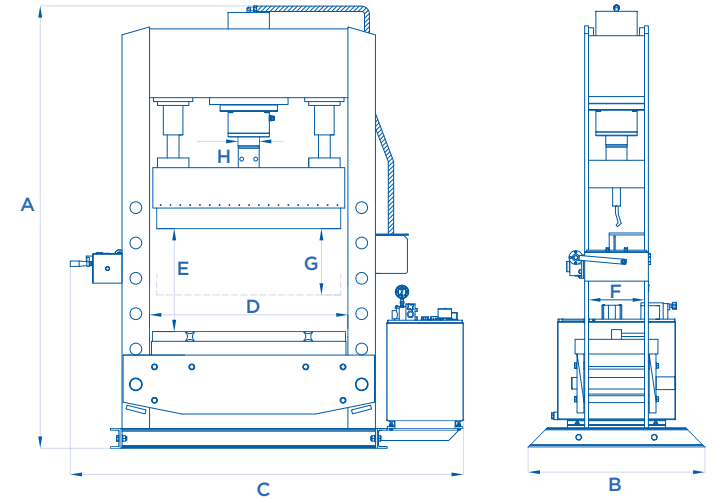

ART.	TON	 mm/min	 mm/min	 mm	 mm	 mm	 mm	 mm	 mm	 mm	 mm		 KG
<b>164/RP</b>	100	1600	180	2260	900	1950	1050	400	280	310	110	3 kw	1700
<b>164/RPA</b>	100	1600	180	2300	900	1950	1050	400	280	300	110	3 kw	1900
<b>204/RP</b>	150	1600	120	2500	1300	2530	1500	400	410	400	140	4 kw	3100
<b>204/RPA</b>	150	1600	120	2850	1200	2550	1500	400	410	400	140	4 kw	3100

 Potenza motore • Motor power • Puissance moteur • Motorleistung  Velocità lavoro • Working speed • Vitesse travail • Arbeitsgeschwindigkeit

 Velocità avvicinamento • Approaching speed • Vitesse approche • Vorlaufgeschwindigkeit

## TRACCIATO TECNICO COSTRUTTIVO

- Stelo del cilindro in acciaio speciale, trattato e cromato.
- Lama in acciaio ad altissima resistenza.
- **Dotate di una particolare matrice che ospita 5 differenti impronte. Cinque accessori in uno.**
- Dispositivo elettrico di finecorsa.
- Centralina motorizzata a due velocità ad inserimento automatico.
- Funzionamento tramite distributore a leva e pulsante sul quadro da azionare contemporaneamente (164/RP - 204/RP).
- Funzionamento tramite pulsantiera di comando a due mani che consente manovre automatiche condizionate dal dispositivo di finecorsa (164/RPA - 204/RPA).
- Complete di pannelli protettivi posteriore e laterali in acciaio zincato.
- Dotate di valvola di taratura per regolare la potenza in base alla lavorazione da eseguire.
- Per lastre fino a 10 mm. di spessore a mt. 1 di larghezza.

## TECHNICAL AND STRUCTURAL LAY-OUT

- Shafts of treated and chromium-plated special steel.
- Blade made of high resistance steel.
- **Supplied with a special forming-die housing 5 different forms. 5 accessories in 1.**
- Electric limit switch device.
- Motorized 2-speeds control unit with automatic insertion.
- Operated by a lever distributor and a button on the control box to be activated simultaneously (164/RP - 204/RP).
- Operated by a two-hand pushbutton board to control automatic operations conditionally to the limit switch device (164/RPA - 204/RPA).
- Protection rear and lateral panels made of zinc-plated steel.
- Calibrating valve to control the power according to the work you have to do.
- For press-bending plates up to 10 mm. thick and 1 mt. wide.

## RELEVÉ TECHNIQUE

- Tige du cylindre en acier spécial traité et chromé.
- lame en acier haute résistance.
- **Livré avec une matrice spéciale qui comprend 5 moules différents. 5 accessoires en un.**
- Dispositif électrique de fin de course.
- Groupe hydraulique motorisé à deux vitesses à insertion automatique.
- Fonctionnement par distributeur à levier et bouton sur le boîtier à activer en simultanée (164/RP - 204/RP).
- Pupitre à boutons poussoir pour les manœuvres automatiques contrôlées par le dispositif de fin de course (164/RPA - 204/RPA).
- Panneaux de protection arrières et sur les côtés en acier galvanisé.
- Soupape de calibrage pour régler la puissance en fonction du travail à faire.
- Pour tôle jusqu'à 10 mm. d'épaisseur et 1 mt. de largeur.

## TECHNISCHE UND KONSTRUKTIVE ANGABEN

- Zylinderkolben aus speziellen Stahl, behandelt sowie auch verchromt.
- Messer aus sehr haltbaren Stahl.
- **Mit eine spezielle Matrice, um 5 besondere Biegeformen zu unterstellen. 5 Zubehöre in nur 1.**
- **Elektroendschalter.**
- Zweistufiges motorisiertes Steuergerät mit automatischen Einstecken.
- Betrieb mittels einem Hebelverteiler und einem Druckknopf auf die Schaltkaste, die gleichzeitig geschaltet sein müssen (164/RP - 204/RP).
- Betrieb mittels einem Zweihand-Schalttafel, wodurch automatische Bedienung möglich sind, die vom Endschalter beeinflusst werden (164/RPA - 204/RPA).
- Mit hinter- und seitlich Schutztafel aus verzinktem Stahl.
- Mit einem Eichventil, um die Kraft der Maschine gemäß die Arbeitstypologie zu regeln.
- Für Blechplatten bis zu 10 mm. Stärke und 1 m Breite.



50•150  
TON

# PRESSE ELETTRIDRAULICHE A MONTANTE MOBILE

ELECTROHYDRAULIC PRESSES WITH MOVABLE STANCHION

PRESSES ELECTROHYDRAULIQUES A MONTANT MOBILE

ELEKTROHYDRAULISCHE PRESSEN MIT BEWEGLICHEM STÄNDER

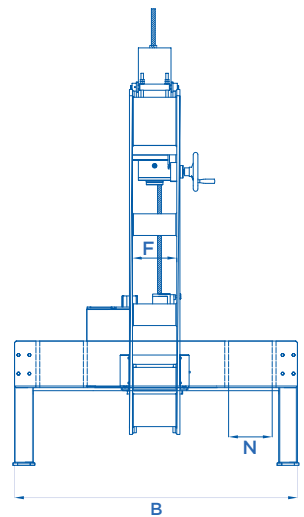
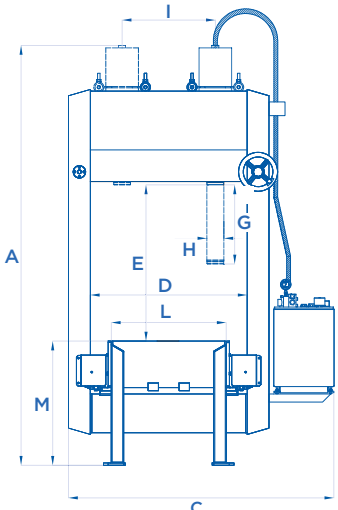

ART. 164/WM

⚙️ Potenza motore • Motor power • Puissance moteur • Motorleistung  
⌚ Velocità avvicinamento • Approaching speed • Vitesse approche • Vorlaufgeschwindigkeit

⌚ Velocità lavoro • Working speed • Vitesse travail • Arbeitsgeschwindigkeit

## TRACCIATO TECNICO COSTRUTTIVO

- Presse dotate di montante e cilindro traslabili manualmente.
- Ideale per svariati utilizzi quali montaggi, raddrizzature, piegature ed estrazioni.
- Scorrimento del montante su rulli in acciaio pieno completi di cuscinetti.
- Stelo del cilindro in acciaio speciale, trattato e cromato.
- Set di due prolunghe per aumentare la corsa utile dello stelo (accessorio).
- Set di prismi componibili in base al tipo di lavorazione da eseguire (accessorio).
- Centralina motorizzata a due velocità ad inserimento automatico.
- **Azionamento tramite distributore a leva a 3 posizioni. Questa soluzione permette di avere una mano libera per lavorare.**
- Dotate di valvola di taratura per regolare la potenza in base alla lavorazione da eseguire.
- Manometro fornito di serie.

## TECHNICAL AND STRUCTURAL LAY-OUT

- Stanchion and cylinder manually movable.
- Perfect for different uses like mounting, straightening, folding and extracting.
- Stanchion move on full steel rollers with bearings.
- Shafts of treated and chromium-plated special steel.
- Set of two extensions to increase the shaft's stroke (optional).
- Set of modular V-blocks according to the kind of work you have to do (optional).
- Motorized 2-speeds control unit with automatic insertion.
- **Start-up by 3-position lever distributor. This solution allows you to have one hand free to work.**
- Calibrating valve to control the power according to the work you have to do.
- Supplied with a manometer.

## RELEVÉ TECHNIQUE

- Presses à montants et vérins mobiles.
- Manœuvrables à la main.
- Idéale pour de multiples utilisations: montage, redressage, pliage et extraction.
- Les montants se déplacent sur galets en acier plein sur roulements.
- Tige du vérin en acier spécial traité et chromé.
- Jeu de deux rallonges pour augmenter la course utile du vérin (en option).
- Jeu de prismes modulaires en fonction du travail à faire (en option).
- Groupe hydraulique motorisé à deux vitesses à insertion automatique.
- **Actionnement par distributeur à levier à 3 positions. Cette solution permet d'avoir une main libre pour travailler.**
- Soupape de calibrage pour régler la puissance en fonction du travail à faire.
- Manomètre de série.

## TECHNISCHE UND KONSTRUKTIVE ANGABEN

- Pressen mit Manuell schwenkbaren Ständer und Zylinder.
- Für verschiedenartige Benutzungen, wie Montagen, Richten, Verbiegungen und Ausziehungen geeignet.
- Der Ständer gleitet auf Vollstahlrollen mit Lager.
- Zylinderkolben aus speziellen Stahl, behandelt sowie auch verchromt.
- Satz von Verlängerungen, um den Kolbenhub zu vergrößern (zusätzlich).
- Satz von zusammensetzbare Prismenblöcken gemäß die Arbeitstypologie (zusätzlich).
- Zweistufiges motorisiertes Steuergerät mit automatischen Einstecken.
- Antrieb mittels einem Hebel-Dreiwegeverteiler.
- **Diese Lösung erlaubt Sie einem Freihand zu haben, um zu arbeiten.**
- Mit einem Eichventil, um die Kraft der Maschine gemäß die Arbeitstypologie zu regeln.
- Serienmäßiger Manometer.

ART.	TON	 mm/min	 mm/min	 A mm	 B mm	 C mm	 D mm	 E mm	 F mm	 G mm	 H mm	 I mm	 L mm	 M mm	 N mm	
<b>162/WM</b>	50	600	215	2450	1600	1600	890	810	235	500	60	590	710	800	280	1,5 kw
<b>164/WM</b>	100	570	180	2700	1820	1750	1010	1000	285	500	110	600	740	800	280	3 kw
<b>204/WM</b>	150	590	120	2900	2000	1950	1210	1000	360	500	140	750	1010	900	380	4 kw

## ACCESSORI EXTRA DOTAZIONE

EXTRA EQUIPMENT • ACCESSOIRES EN OPTION • EXTRA ZUBEHÖR

### SET DI PROLUNGHE (2)

Pair of extensions  
Paire de rallonges  
2 Verlängerungen

ART.	 mm	Compatibilità Compatibility Kompatibilität
<b>040</b>	150	ART. 162/WM
<b>040/A</b>	250	ART. 164/WM
<b>040/B</b>	250	ART. 204/WM



### SET DI PRISMI componibili

Set of modular blocks  
Jeu de 4 prismes modulables  
Zusammensetzbare Prismenblöcke

- ART. 038 ✓ ART. 162/WM
- ART. 038/A ✓ ART. 164/WM
- ART. 038/B ✓ ART. 204/WM

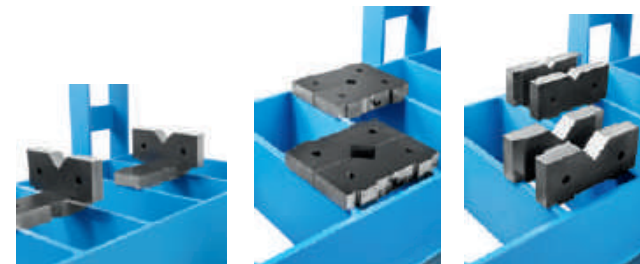

## ACCESSORI EXTRA DOTAZIONE

EXTRA EQUIPMENT • ACCESSOIRES EN OPTION • EXTRA ZUBEHÖR

### PRISMI A V

V Blocks

Prismes à V

Prismenblöcke

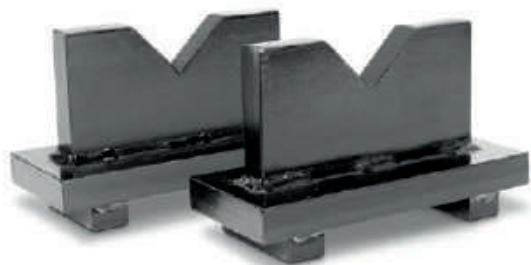
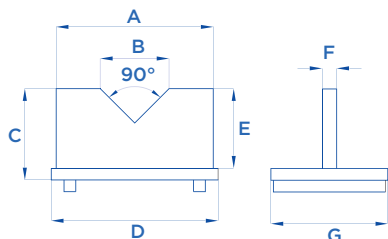

ART.	Compatibilità Compatibility Compatibilité Kompatibilität	A mm	B mm	C mm	D mm	E mm	F mm	G mm	KG
<b>030</b>	SERIE 10 TON	160	70	95	170	80	15	120	4
<b>031</b>	SERIE 15 - 20 TON	160	70	95	190	80	15	120	8
<b>031/A</b>	SERIE 30 TON	190	80	125	240	100	25	100	9
<b>031/B</b>	SERIE 40 TON	250	100	145	300	120	25	100	12
<b>032</b>	SERIE 50 TON	250	100	145	320	120	25	100	13
<b>032/A</b>	SERIE 50 TON + ART. 022	330	100	180	380	150	30	100	20
<b>033</b>	SERIE 70 TON	330	100	180	380	150	30	100	20
<b>034</b>	SERIE 100 TON (D = 1000 mm)	330	100	180	410	150	30	100	20
<b>034/A</b>	SERIE 100 TON + ART. 022/A SERIE 100 TON (D = 1500 mm)	330	100	190	480	150	30	120	32
<b>035</b>	SERIE 150 TON	450	100	220	560	180	40	120	58
<b>036</b>	SERIE 200 TON	450	100	220	880	180	40	120	60
<b>037</b>	SERIE 300 TON	450	100	220	1000	200	80	150	116



### MANOMETRO

Manometers

Manomètres

Manometer

**ART. 001** Ø 100 mm

✓ ART. 153 • 154/E • 154 • 155  
156 • 154/P • 155/P • 156/P



**ART. 002** Ø 63 mm

✓ ART. 152

**ART. 002/A** Ø 100 mm

✓ ART. 154/IP • 155/IP • 156/IP

### PIATTO CACCIASPINE

Pin-extracting plate

Plateaux à trous

Auflageplatte

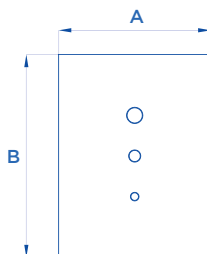
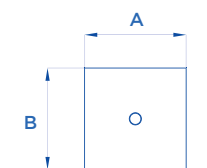

ART.	Compatibilità Compatibility Compatibilité Kompatibilität	A mm	B mm	Diametro Diameter Diamètre Durchmesser	KG
<b>010</b>	SERIE 10 TON	200	200	22 mm	5
<b>011</b>	SERIE 15 - 20 TON	200	200	22 mm	5
<b>011/A</b>	SERIE 30 TON	240	400	15 - 22 - 28 mm	23
<b>012</b>	SERIE 40 - 50 TON	300	400	15 - 22 - 28 mm	28
<b>012/A</b>	SERIE 50 TON + ART. 022	400	400	15 - 22 - 28 mm	50
<b>013</b>	SERIE 70 TON	400	400	15 - 22 - 28 mm	50
<b>014</b>	SERIE 100 TON (D = 1000 mm)	400	400	15 - 22 - 28 mm	63
<b>014/A</b>	SERIE 100 TON + ART. 022/A SERIE 100 TON (D = 1500 mm)	480	480	20 - 30 - 40 mm	90
<b>015</b>	SERIE 150 TON	550	550	20 - 30 - 40 mm	118

D = Luce pressa • Width between uprights • Distance entre les montants • Licht Breite

## ACCESSORI EXTRA DOTAZIONE

EXTRA EQUIPMENT • ACCESSOIRES EN OPTION • EXTRA ZUBEHÖR

### ACCESSORI

Accessories  
Accessoires  
Zubehör

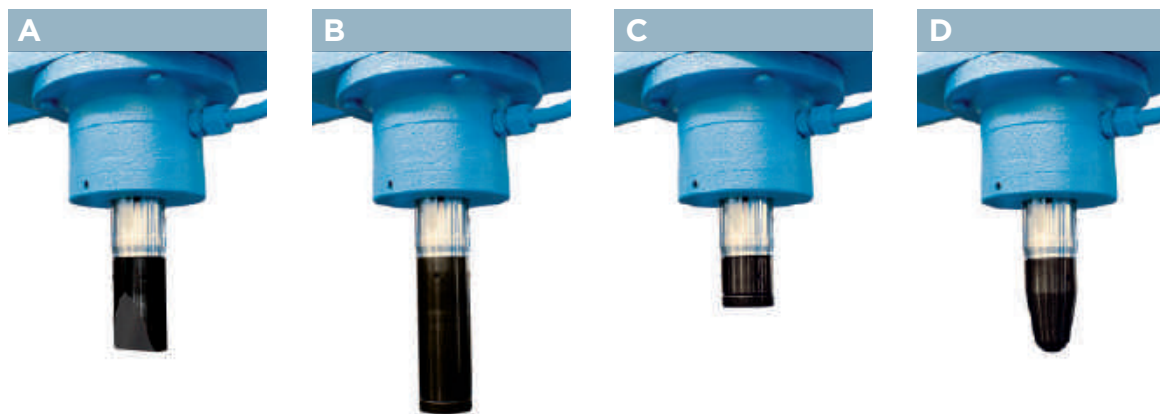
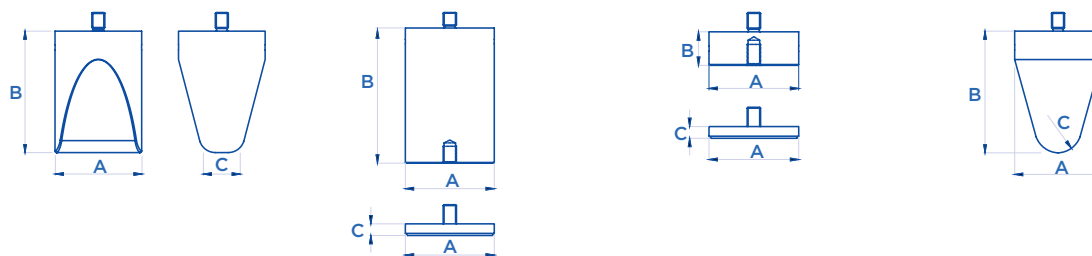

ART. 041 • 041/A

ART. 042 • 042/A

ART. 043 • 043/A

ART. 044 • 044/A

ART.	Compatibilità Compatibility Compatibilité Kompatibilität	A mm	B mm	C mm
<b>041</b>	SERIE 30 - 40 - 50 TON	57	100	25
<b>041/A</b>	SERIE 70 - 100 TON	107	150	45
<b>042</b>	SERIE 30 - 40 - 50 TON	57	150	14
<b>042/A</b>	SERIE 70 - 100 TON	107	200	14
<b>043</b>	SERIE 30 - 40 - 50 TON	57	40	14
<b>043/A</b>	SERIE 70 - 100 TON	107	40	14
<b>044</b>	SERIE 30 - 40 - 50 TON	57	100	20
<b>044/A</b>	SERIE 70 - 100 TON	107	150	30

### SET DI 8 PERNI CACCIASPINE

Set of 8 mandrels

Jeu de 8 mandrins

Satz mit 8 Dornsätzen

ART. 045 ✓ SERIE 10 - 15 - 20 - 30 TON

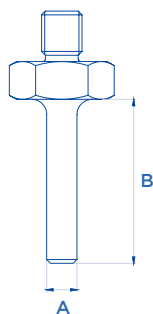

A mm	B mm	Forza di spinta massima Maximum thrust force Force de poussée maximale Max. Schubkraft
12	65	0,8 TON
14	65	1 TON
16	65	1,5 TON
18	65	2 TON
20	65	2,5 TON
22	65	3 TON
25	65	3,8 TON
30	65	5 TON



## ACCESSORI EXTRA DOTAZIONE

EXTRA EQUIPMENT • ACCESSOIRES EN OPTION • EXTRA ZUBEHÖR

### PANNELLO DI PROTEZIONE FRONTALE

Front protection panel

Panneau de protection avant

Vordere Schutzplatte

ART.

Compatibilità  
Compatibility  
Compatibilité  
Kompatibilität

**090**

SERIE 10 - 15 - 20 TON

**090/A**

SERIE 30 TON

**090/B**

SERIE 40 - 50 TON

**090/C**

SERIE 70 TON

**090/D**

SERIE 100 TON (D = 1000 mm)

**090/E**

SERIE 150 TON (D = 1000 mm)



## ACCESSORI EXTRA DOTAZIONE

EXTRA EQUIPMENT • ACCESSOIRES EN OPTION • EXTRA ZUBEHÖR

### CONTROPUNTE REGISTRABILI

Pair of adjustable centers

Paire de contrepointes réglables

Zentriervorrichtung



ART. 051

ART. 050 ✓ SERIE 10 - 15 - 20 TON

ART. 051 ✓ SERIE 30 - 40 - 50 - 70 - 100 TON

ART. 052 ✓ SERIE 150 TON (D = 1000 mm)

ART. 053 ✓ SERIE 100 - 150 TON (D = 1500 mm)

### PIASTRA FRESATA CON CAVE A T

Tee slots milled plate

Plaque fraisée avec carrières à T

Auflageplatte mit Nuten als Pressformenhalterung

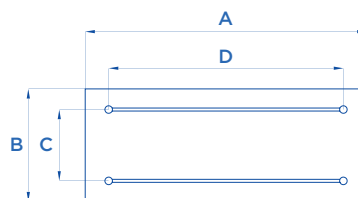

ART.

Compatibilità  
Compatibility  
Compatibilité  
Kompatibilität

A mm

B mm

C mm

D mm

KG

080

SERIE 40 - 50 TON

750

400

160

600

100

081

SERIE 70 TON

850

450

270

700

170

082

SERIE 100 TON (D = 1000 mm)

990

500

300

800

220

083

SERIE 150 TON (D = 1000 mm)

1000

600

380

800

320

084

SERIE 100 - 150 TON (D = 1500 mm)

1500

600

380

1250

480

### DISPOSITIVO ELETTRICO DI FINE CORSA

Stop electric device

Dispositif électrique de fin de course

Elektroendschalter



ART. 060 ✓ SERIE 40 - 50 - 70 - 100 TON

ART. 061 ✓ SERIE 150 - 200 TON

ART. 062 ✓ SERIE 300 TON

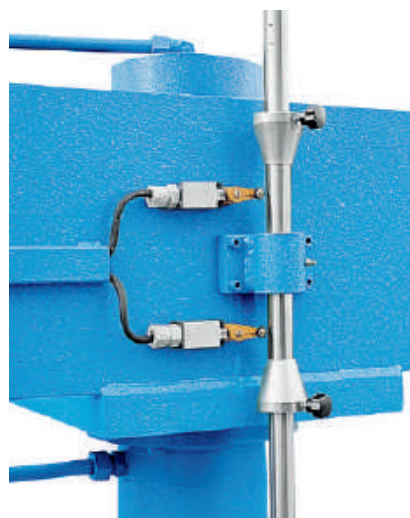

### DISPOSITIVO ANTIROTAZIONE STELO

Anti-rotation device of piston rod

Dispositif anti-rotation de la tige

Rotations-Stoppeinrichtung



ART. 070 ✓ SERIE 40 - 50 TON

ART. 071 ✓ SERIE 70 - 100 TON

ART. 072 ✓ SERIE 150 - 200 TON

ART. 073 ✓ SERIE 300 TON

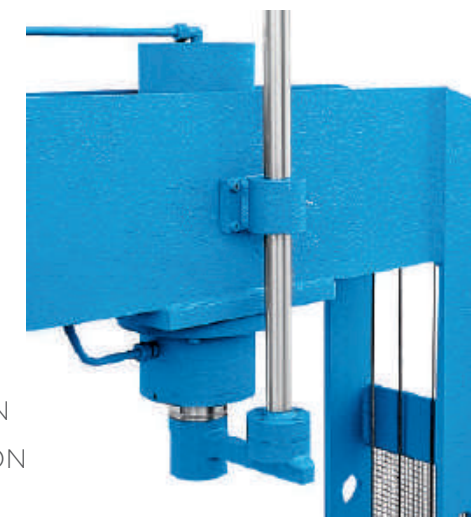

### CILINDRO MOBILE

Mobile ram  
Piston mobile  
Versetzbarem Zylinder



#### ART. 020

✓ ART. 153 • 154 • 155 • 156 • 154/IP •  
155/IP • 156/IP • 154/P • 155/P • 156/P

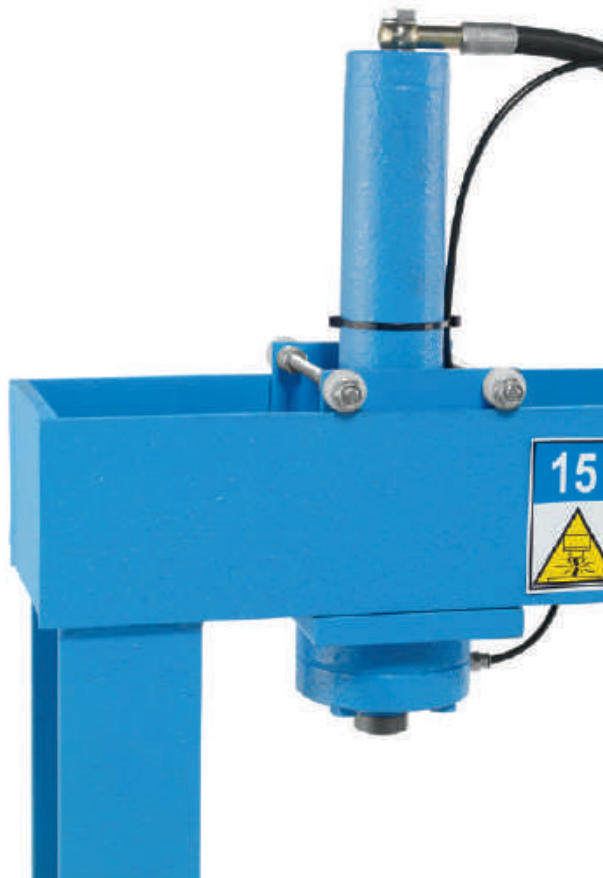

#### ART. 021

✓ ART. P30/SA • P30/SAIP • P30/SAP

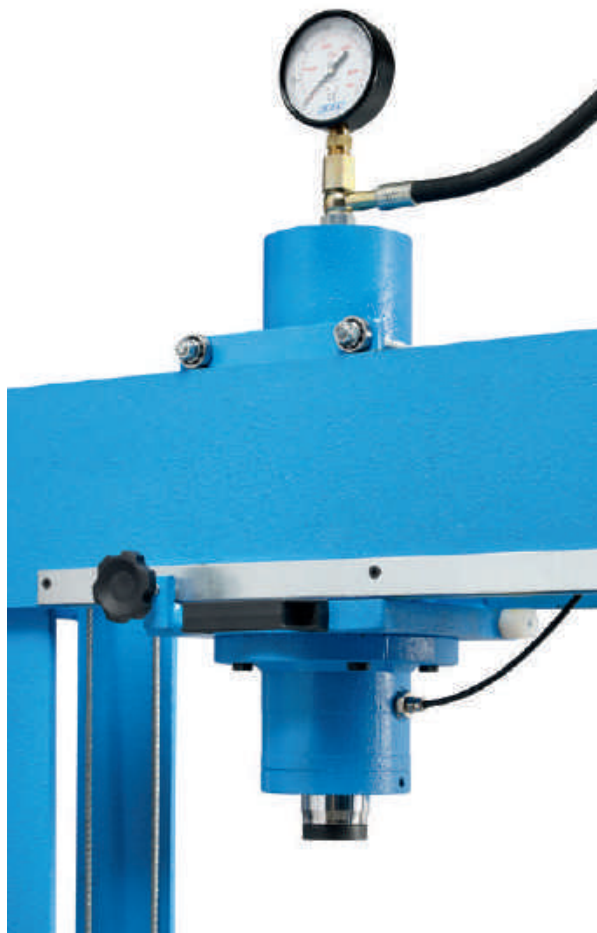

#### ART. 022\*



ART. 162/W • 162/R

#### ART. 022/A\*



ART. 164/W • 164/WS • 164/R • 164/RS

#### ART. 022/B\*



ART. 204/W • 204/R

#### ART. 022/C



ART. 205/W • 205/R

#### ART. 022/D



ART. 280/W • 280/R



- Cinquantennale esperienza realizzativa.
- Oltre settanta modelli di serie con capacità da 6 a 300 ton.
- Esecuzioni speciali per tipologia, dimensioni e capacità.
- Presenza distributiva a livello mondiale.
- La soluzione ideale per le vostre esigenze.

- Fifty-year-long experience.
- Over seventy standard models with capacity from 6 to 300 ton.
- Special executions for typology, dimensions and capacity.
- Worldwide presence.
- The ideal solution for your needs

- Un demi-siècle d'expérience.
- Plus de soixante-dix modèles de série d'une capacité de 6 à 300 ton.
- Réalisation sur demande selon type, dimensions et capacité.
- Présence effective au niveau mondial.
- La réponse idéale à vos exigences.

- Fünfzigjährige Erfahrung.
- Mehr als siebenzig Standard-Ausführungen mit einer Kapazität von 6 bis 300 t.
- Sonderausführungen mit abweichenden Maßen und Kapazitäten möglich.
- Weltweiter Vertrieb.
- Die beste Lösung für Ihre Bedürfnisse.

**SPECIAL  
LINE**

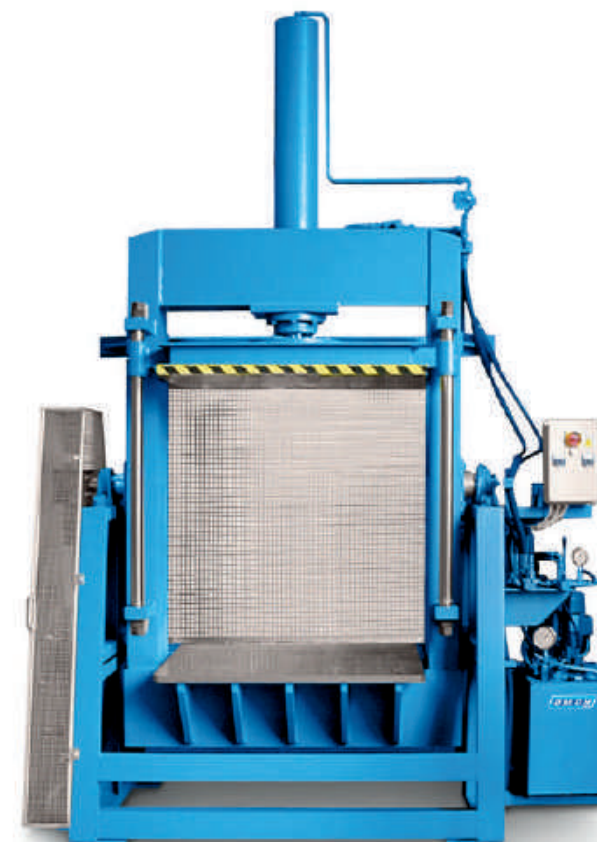
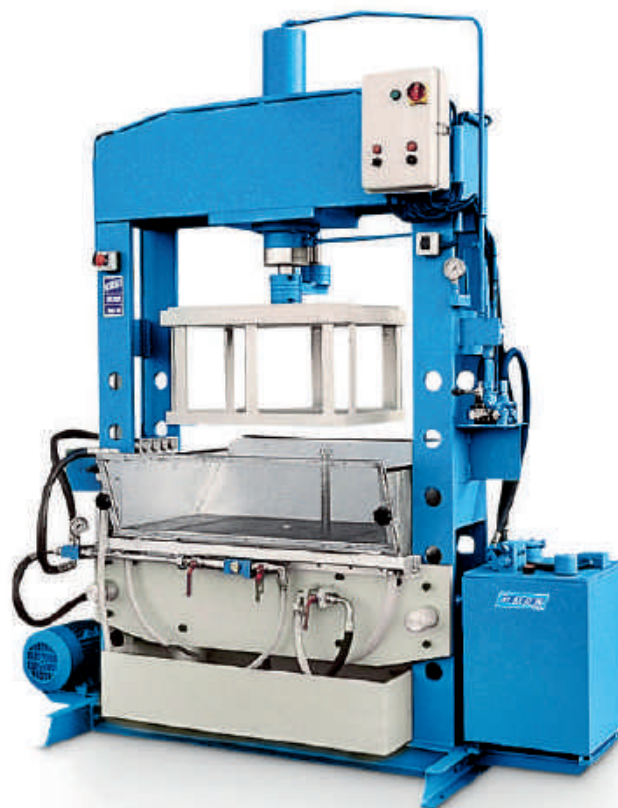



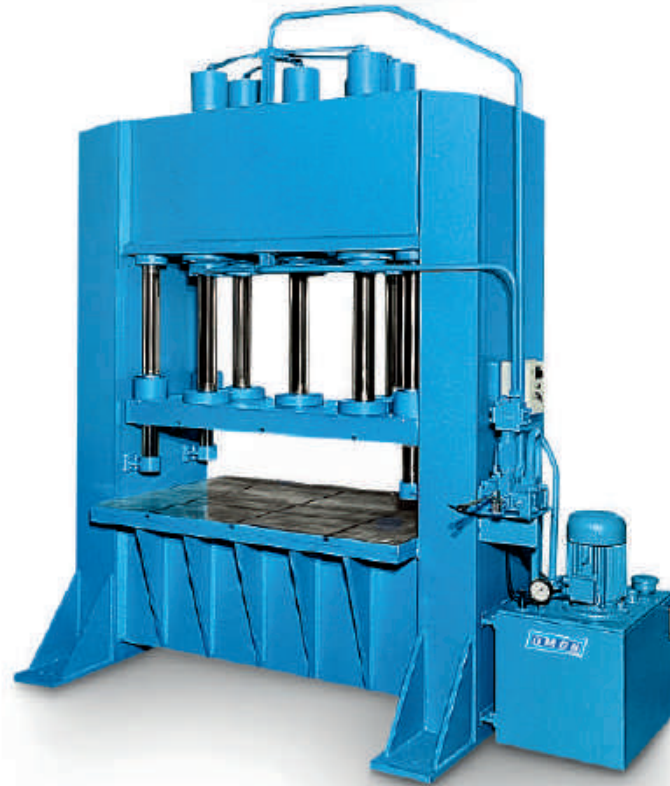
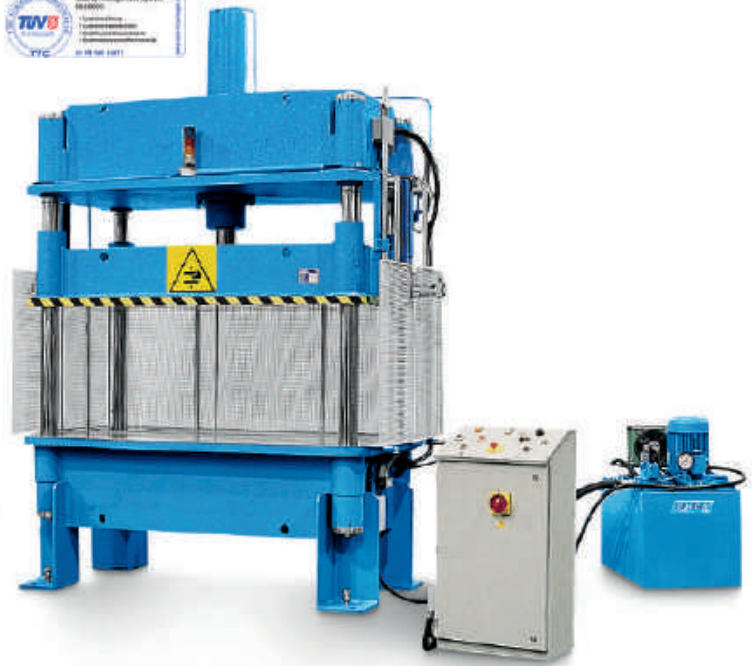



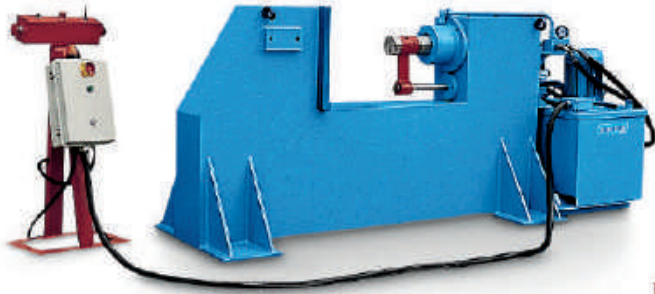

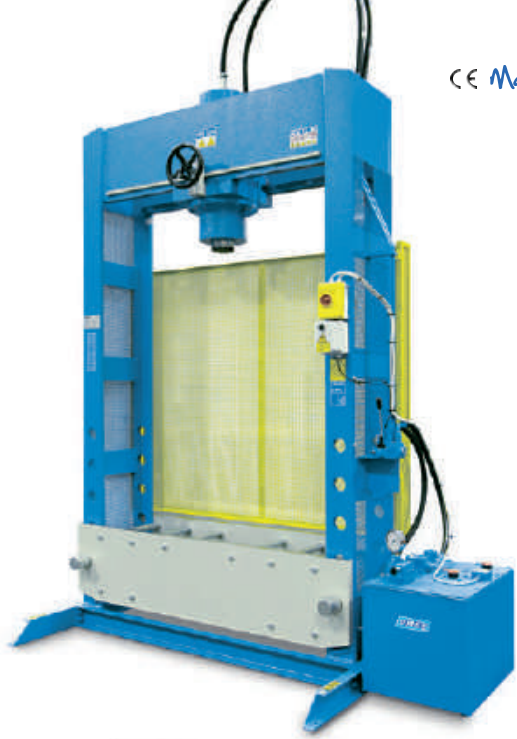



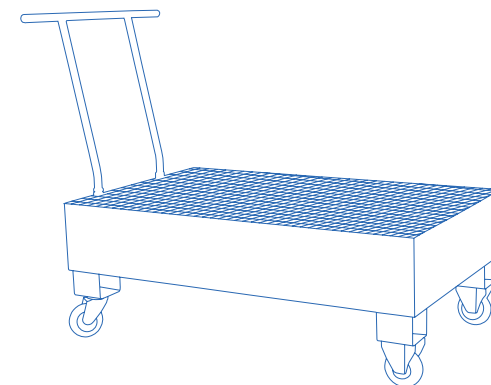

**ATTREZZI ECOLOGICI**

ENVIRONMENTAL EQUIPMENT  
OUTILS ECOLOGIQUES  
ENTSORGUNGSGERÄTE

Made in Italy 

## PRESSA ELETTRIDRAULICA SCHIACCIA FILTRI

ELECTROHYDRAULIC FILTER CRUSHER  
PRESSE ELECTROHYDRAULIQUE ECRASE FILTRES  
ELEKTROHYDRAULISCHE FILTER-PRESSE



ART. 389/A

## ART. 389/A

Pressa elettroidraulica a due velocità di lavoro. Compatta i filtri olio di tutti gli autoveicoli ed ottiene un doppio risultato: il recupero totale dell'olio residuo e la massima riduzione dell'ingombro dei filtri stessi. L'olio ed i filtri schiacciati vengono raccolti automaticamente a caduta libera in due distinti contenitori. Il contenitore per i filtri è munito di un cestello che, oltre alla raccolta degli stessi, consente lo sgocciolamento dell'eventuale minimo residuo di olio. I benefici ecologici, il ritorno economico derivato dal recupero e dalla facilitazione di riciclaggio dell'olio e dei filtri, la sua realizzazione in armadio carrellato (quattro ruote di cui due orientabili) e gli accorgimenti antinfortunistici testimoniano l'indiscussa utilità in qualsiasi officina di questa schiaccia filtri. Relé di sicurezza chiusura vano di lavoro.

Two working speed electrohydraulic press. It compresses the oil filters of every vehicle and it obtains the total salvage of the residual oil and of the highest reduction of encumbrance of the filters themselves. The oil and compressed filters are automatically collected in free-fall in two separated containers. The filter container is equipped with a basket that, besides collecting the filters, allows the dripping of the possible residual oil. The undisputed usefulness of this filter crusher in any car workshop is proved by the environmental benefits, the economic return derived from the salvage and the oil and filter recycling facilities, the fact that it is structured as a trolley cupboard (with four wheels of which two revolving) and the accident-prevention devices. Safety relay controlled closure of the working room.

Presse électrohydraulique, à deux vitesses de travail. Elle comprime les filtres d'huile de toutes les voitures en obtenant un double résultat la récupération des résidus d'huile et la réduction maximale des filtres eux-mêmes. L'huile et les filtres écrasés sont récupérés automatiquement dans deux réceptacles distincts. Le réceptacle à filtre est équipé d'un panier percé, pour recueillir un éventuel résidu d'huile. Les bénéfices écologiques, le retour économique qui passe par la récupération et la facilité de recyclage des filtres et de l'huile, sa présentation en armoire amovible (quatre roues dont 2 pivotantes) et les normes de travail, témoignent de l'indiscutable utilité de l'écrase filtres dans tous les garages.

Elektrohydraulische Presse mit 2 Arbeitsgeschwindigkeiten. Ölfilter jeden Fahrzeugtyps lassen sich hiermit zusammenpressen, wobei das anfallende Altöl gesammelt wird. Öl und Filter werden automatisch in zwei Behältern gesammelt; durch einen Korbeinsatz im Filtersammelbehälter kann das im Filter verbliebene Restöl abtropfen. Die unbestrittenen Vorteile der Filter-Pressen liegen in ihrer Umweltfreundlichkeit, d.h. der getrennten Wiederverwertung von Altöl und der anfallenden Reststoffe, der Konzeption als Schrankwagen (4 Räder - 2 davon drehbar) sowie entsprechenden Vorrichtungen zur Unfallverhütung. Das Schließen der Preßkammer wird durch ein Sicherheitsrelais gesteuert.

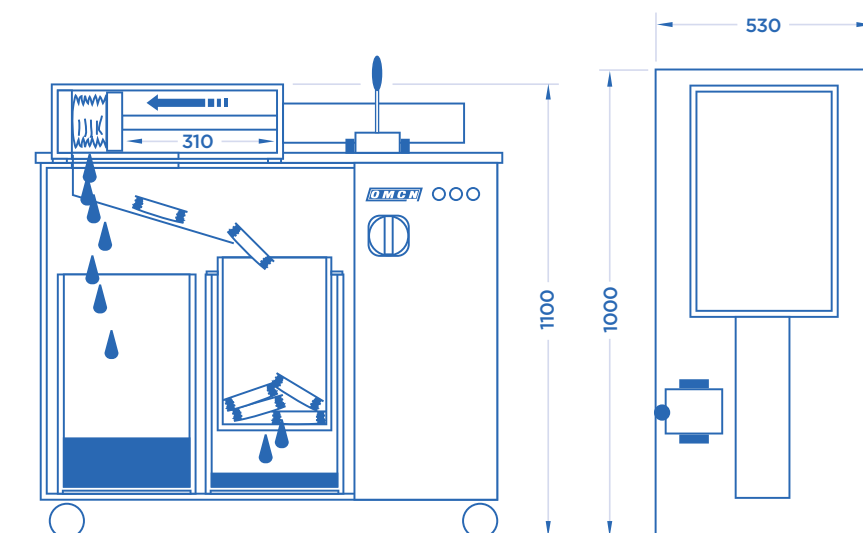

<b>ART.</b>	<b>TON</b>		Dimensioni camera Working room dimensions Dimensions chambre Maße der Preßkammer	
<b>389/A</b>	40	1,5 kw	175 x 260 x 320 mm	250

 Potenza motore • Motor power • Puissance moteur • Motorleistung



## PRESSE IDRAULICHE SCHIACCIA BARATTOLI

CAN CRUSHING HYDRAULIC PRESSES  
PRESSES HYDRAULIQUES A COMPRIMER LES POTS ET BIDON DE PEINTURE  
HYDRAULIK-PRESSE FÜR DAS ZUSAMMENPRESSEN VON BLECHDOSEN

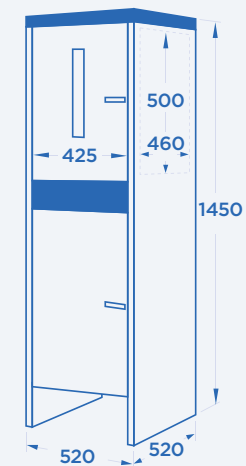

**ART. 390/A**



**ART. 390/B**

### ART. 390/A

Pressa completa di pompa elettroidraulica.

Press complete with electrohydraulic pump.

Presse munie de pompe électrohydraulique.

Presse, komplett ausgestattet mit elektrohydraulischer Pumpe.

### ART. 390/B

Pressa completa di pompa idropneumatica.

Press complete with hydropneumatic pump.

Presse munie de pompe hydropneumatique.

Presse, komplett ausgestattet mit pneumatisch-hydraulischer Pumpe.

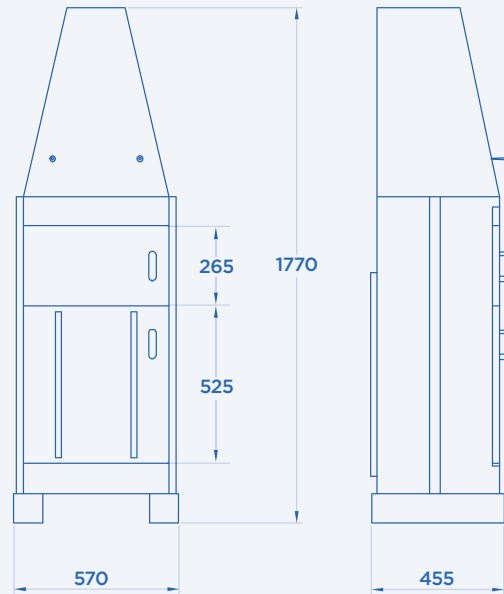

ART.	KG	Corsa pistone Ram stroke Course du piston Kolbenhub					
			mm	mm	mm	mm	KG
396	700	500 mm	10 bar	500	780	400	150

Indicata per carta e cartone, a funzionamento pneumatico è dotata di doppio bloccaggio di sicurezza e di pianale inferiore parzialmente estraibile per una più facile evacuazione della palla formata.

Indicated for paper and cardboard, pneumatic working it is provided with twin safety locking and lower partially extractable planal for an easier evacuation of the formed bale.

Indiquée pour le traitement des papier et carton. Fonctionnement pneumatique. Pourvu d'un double blocage de sécurité et d'un fond extractible pour faciliter l'évacuation de la balle formée.

Pneumatisch arbeitende Presse für Papier und Pappe, ausgestattet mit doppeltem Sicherheitsverschluß und einem teilweise ausziehbareren Tisch, mit dessen Hilfe, sich der gepreßte Ballen einfach entnehmen läßt.

\*Dimensioni vano • Room dimensions • Dimensions de la chambre • Ballenmaße

Pressione di utilizzo • Feeding pressure • Pression d'alimentation • Benötigter Luftdruck

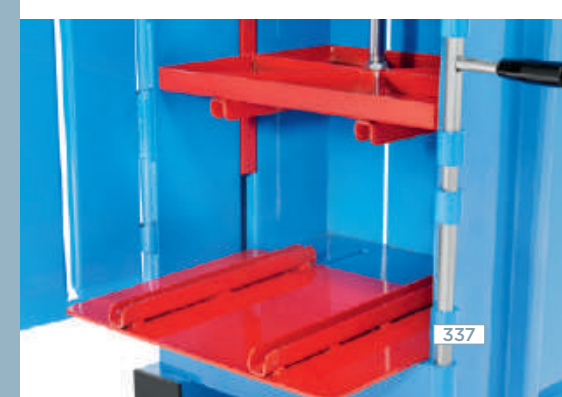

## VASCHE ECOLOGICHE

TANKS OF DUMP AGAINST THE ACCIDENTAL LOSSES  
BACS DE RECOLTE CONTRE LES FUITES ACCIDENTELLES  
ÖLAUFFANGBEHÄLTER

Da posizionare su superfici piane, protette dalla pioggia. In presenza di immagazzinaggio di sostanze diverse, le stesse dovranno essere tra loro compatibili.

To put on plane surfaces, protected by the rain. If there is a storing of different substances, these ones shall be each others compatible.

A positionner sur des surfaces planes à l'écart des intempéries. Ne pas stocker ensemble des produits incompatibles.

Dieser Behälter dient zum Auffangen von ÖL aus undichten oder überlaufenden Ölfässern.

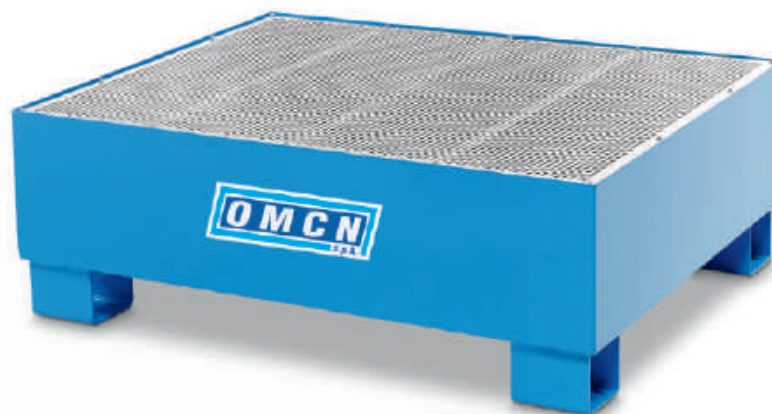

ART. 5000



ART. 5001/M

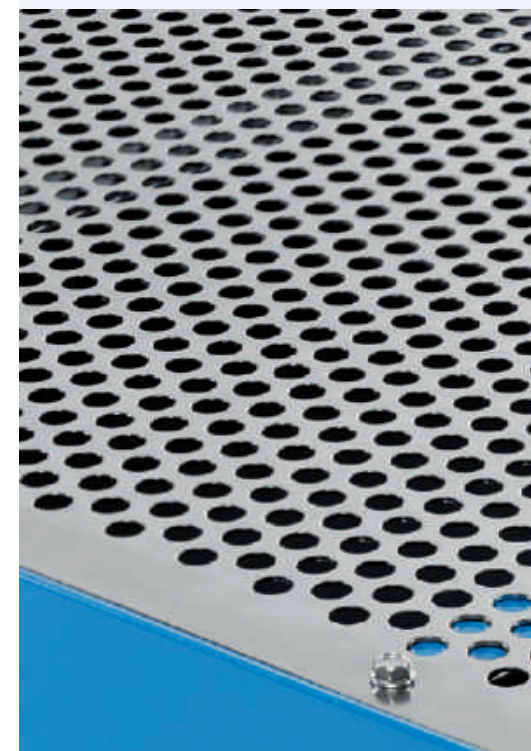

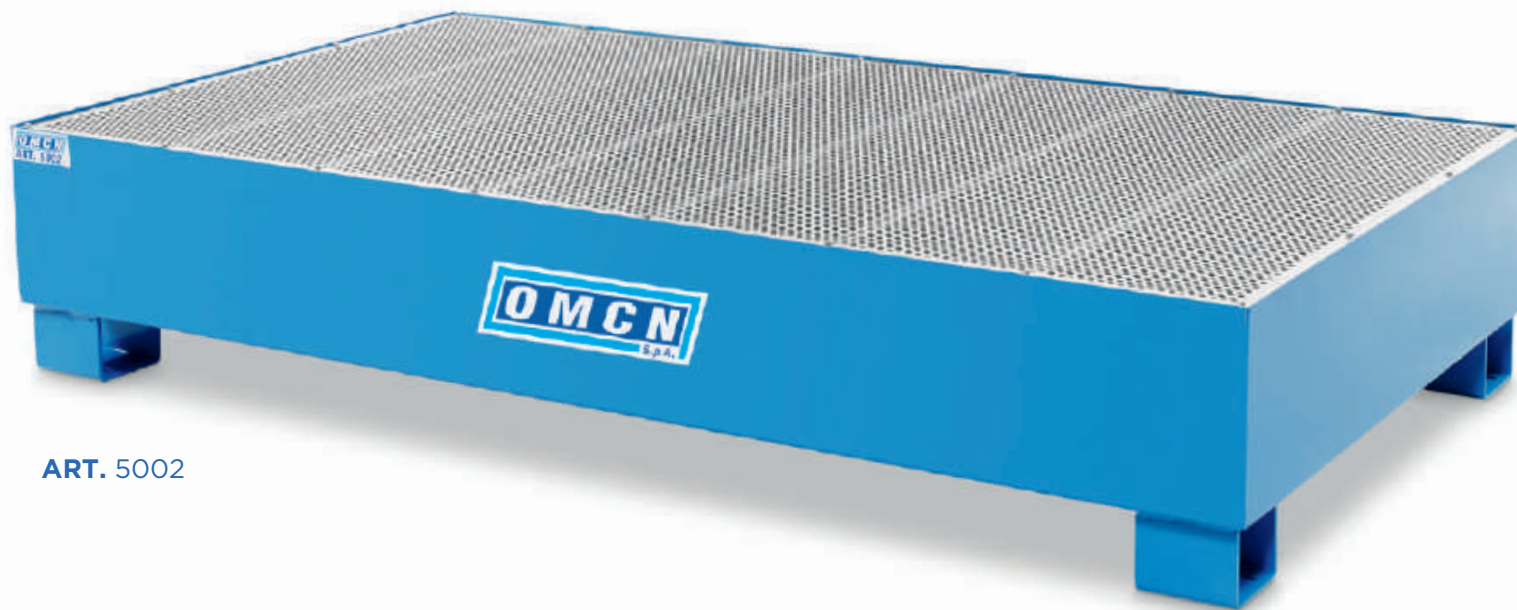

ART. 5002

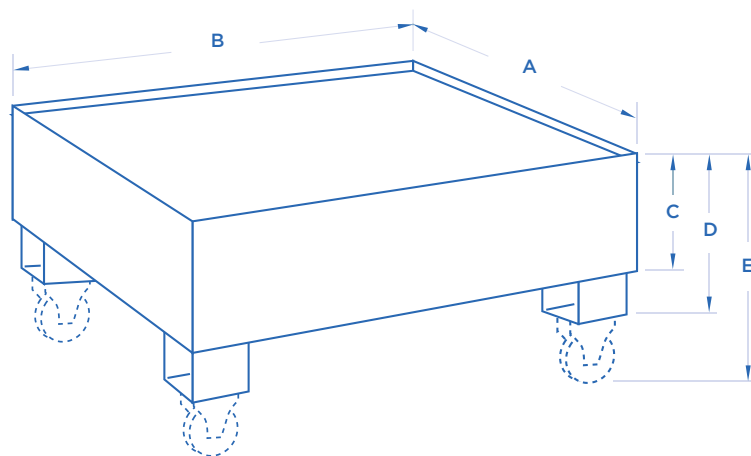

ART.		A mm	B mm	C mm	D mm	E mm	KG
5000	210	850	1000	250	355		54
5000/M	210	850	1000	250	355	525	60
5001	285	850	1350	250	355		80
5001/M	285	850	1350	250	355	525	86
5002	450	1000	1800	250	355		113
5002/M	450	1000	1800	250	355	525	120

 Capacità • Capacity • Capacité • Belastbarkeit

 Versione mobile • Mobile version • Version mobile • Fahrbare Ausführung

**CONDIZIONI GENERALI DI VENDITA:** Gli articoli o gruppi di articoli contraddistinti dal marchio CE verranno forniti agli stati membri della Comunità Economica Europea secondo gli standard previsti dalle normative in vigore. Il marchio CE contraddistingue gli articoli che, secondo le vigenti normative europee, devono risultare coperti, a seconda dei casi, da certificazione o da autocertificazione. Per gli Stati non di appartenenza alla Comunità, lo standard esecutivo CE dovrà essere espressamente richiesto. Le figure, i dati, i pesi, le misure d'ingombro, le caratteristiche rilevate dal catalogo non sono impegnative, in quanto ci riserviamo di apportare quelle modifiche necessarie per il sempre migliore funzionamento ed ammodernamento dei nostri prodotti.

**ORDINI:** Gli ordinativi sono da considerarsi accettati quando l'acquirente avrà ricevuto regolare conferma scritta da parte del venditore e la validità dei prezzi sarà quella indicata nella conferma.

**SPEDIZIONI:** Le spedizioni sono eseguite a rischio e pericolo del Committente, le stesse verranno appoggiate al corriere prescritto dal cliente, o in mancanza di questo al corriere più economico di ns. conoscenza, ma senza alcuna ns. responsabilità. Il Committente prima di prendere in consegna dal vettore la merce, dovrà controllare che la spedizione sia completa e in perfetto stato; in caso di ritardo, avaria o perdita durante il trasporto, ogni relativa azione contro il vettore dovrà essere fatta dal Committente.

**CONSEGNE:** I termini di consegna sono da considerarsi indicativi. Eventuali ritardi verranno comunicati dal venditore all'acquirente. Tali ritardi non daranno comunque diritto all'annullamento dell'ordine né tantomeno potranno costituire titolo di rivalsa per danni o penali se non espressamente pattuite per iscritto.

**PAGAMENTI:** Il pagamento delle fatture deve essere fatto a noi direttamente; non si accettano trattenute o arrotondamenti. Nel caso di pagamento per contanti a ricevimento fattura, l'eventuale sconto cassa pattuito va calcolato sul solo importo netto del materiale, esclusa I.V.A., imballo e eventuali spese di trasporto o postali. Trascorsi 15 gg. dalla data della fattura o dal periodo accordato precedentemente, s'intende revocato questo beneficio e pertanto la rimessa va effettuata per il totale della fattura. Qualora i pagamenti non vengano effettuati nei termini pattuiti, la ditta si riterrà autorizzata all'emissione di riba. Si precisa inoltre che inadempimenti nei pagamenti da parte dell'acquirente daranno diritto al venditore di sospendere o annullare eventuali ordini in corso o restanti. Sui pagamenti effettuati in ritardo, rispetto alle scadenze pattuite, saranno dovuti gli interessi di mora secondo i termini di legge.

**RISERVA DI PROPRIETÀ:** I prodotti consegnati dal venditore all'acquirente rimarranno comunque di proprietà del venditore fino all'integrale pagamento della fornitura stessa.

**GARANZIE:** La garanzia dei ns. prodotti è di 24 mesi (solo per il mercato Italia). La garanzia comprende la sostituzione o la riparazione della parte difettosa (componente macchina, o parte di essa). La sostituzione di tale parte non comporta il rinnovo del periodo di garanzia sull'intera macchina, salvo che non si tratti della sostituzione del prodotto completo. Il costruttore resta con ciò esonerato da ogni obbligo di risarcimento a qualsiasi titolo e l'acquirente rinuncia a qualsiasi richiesta per spese o danni anche a terzi dovuti, per eventuali fermo-macchina. Dalla garanzia restano escluse le parti accidentalmente danneggiate durante il trasporto, per incuria di movimentazione, per errato collegamento alla linea di alimentazione elettrica, nonché le parti soggette a normale usura o deperimento per agenti atmosferici ed ambientali esterni e sono esclusi tutti i guasti derivanti da mancata, insufficiente o errata manutenzione, da imperizia di uso, da uso improprio, da uso non consentito o non previsto, da modifiche o riparazioni non autorizzate e manomissioni. La validità della garanzia è subordinata alla corretta esecuzione delle manutenzioni come descritto nella sezione del manuale riservata alle istruzioni di "uso e manutenzione", che corredano i prodotti. I dati tecnici indicati non sono comunque vincolanti per il produttore. Lo stesso potrà apportare modifiche o migliorie a proprio insindacabile giudizio senza che le stesse possano costituire motivo di contestazione o reso della merce.

**MANUALE DI ISTRUZIONE D'USO E MANUTENZIONE:** Congiuntamente ad ogni singolo prodotto verrà consegnato il manuale di istruzione d'uso e manutenzione e dove dovuta la dichiarazione CE di conformità. Documenti, schemi tecnici e disegni contenuti in detti manuali sono da ritenersi di esclusiva proprietà del venditore sia dal punto di vista intellettuale che industriale.

**ESCLUSIONI DI RESPONSABILITÀ:** Il mancato rispetto delle istruzioni impartite nei manuali rilasciati all'atto della consegna del prodotto solleveranno il venditore dalla responsabilità di danni causati a persone, animali o cose sia in forma diretta che in forma indiretta.

**NORME REGOLATRICI:** Per quanto non espressamente disciplinato dalle presenti "Condizioni generali di vendita" saranno applicabili le norme sulla vendita disciplinata dagli articoli 1470 e seguenti del Codice Civile Italiano.

**DATI PERSONALI:** Ai sensi dell'art. 13 del D.Lgs 196/03 - codice privacy il trattamento dei dati sarà effettuato per permettere la gestione dei rapporti commerciali e di tutte le azioni necessarie allo svolgimento delle attività che andremo ad esercitare inerenti il contratto. Il personale coinvolto nella gestione dei rapporti commerciali è stato debitamente istruito in materia di tutela delle informazioni personali e del diritto alla privacy.

**LEGGE APPLICABILE E FORO COMPETENTE:** Qualsiasi controversia derivante dalla interpretazione, applicazione, esecuzione, risoluzione del contratto e/o delle presenti "Condizioni Generali di vendita" sarà disciplinata dalla Legge Italiana e devoluta in via esclusiva per competenza al Foro Giudiziario di Bergamo (Italy).

**RESPONSABILITÀ PRODOTTO:** Tutti gli articoli sono assicurativamente coperti da polizza "Responsabilità prodotto" valida per un periodo di 10 anni.

**CONDITIONS GENERALES DE VENTE:** Les articles ou groupes d'articles signalés par le logo CE seront fournis aux états membres de la Communauté Economique Européenne selon les standards prévus par les normes en vigueur. Le logo CE signale les articles qui doivent être accompagnés, selon les cas, d'un certificat ou d'une déclaration, et ce, conformément aux normes européennes en vigueur. Pour les Etats en dehors de la Communauté Européenne, le standard CE ne sera exécuté qu'en cas de demande express. Les illustrations, poids, mesures d'encombrement et données techniques indiquées sur le catalogue n'engagent pas le constructeur qui se réserve la possibilité d'apporter des modifications nécessaires à l'amélioration et à la modernisation de ses produits.

**COMMANDES:** Une commande est considérée acceptée quand l'acheteur reçoit un accusé de réception écrit de la part du vendeur. Les prix valables sont ceux indiqués dans l'accusé.

**EXPÉDITIONS:** Expéditions effectuées aux risques et périls de l'acheteur. Elles seront confiées aux transporteurs mandatés par le client ou à défaut, confiées au transporteur le plus économique de notre connaissance, sans engagement d'une quelconque responsabilité OMCN. Avant d'accepter la livraison de la marchandise, l'acheteur devra s'assurer que le chargement soit complet et en parfait état; en cas de retard, avarie ou perte pendant le transport, il incombe à l'acheteur de prendre les mesures appropriées à l'encontre du transporteur.

**LIVRAISON:** Les délais de livraison sont données à titre indicatif. Les retards éventuels sont signalés par le vendeur à l'acheteur. Cependant de tels retards ne donnent pas droit à l'annulation de la commande ni ne peuvent donner lieu à des dommages et intérêts à moins qu'un accord définissant ces conditions n'ait été stipulé par écrit.

**PAIEMENTS:** Les règlements des factures doivent être versés directement à OMCN. Nous n'acceptons ni retenues, ni arrondissements. En cas de règlement comptant à réception de la facture, la remise éventuellement accordée se calcule sur le montant hors taxes de la marchandise hors frais postaux, d'emballage ou de transport. A échéance de 15 jours de la date d'émission de la facture ou de la période convenue au préalable, cette remise est considérée comme caduque et le règlement sera du total de la facture. Nous précisons de plus que tout impayé donne droit au vendeur de suspendre ou d'annuler les éventuelles commandes en cours ou reliquats. En cas de retard de paiement sur les délais concordés, les pénalités sont dues en fonction du taux d'intérêt légal fixé par décret.

**CLAUSE DE PROPRIÉTÉ:** Les produits livrés par le vendeur à l'acheteur restent la propriété du vendeur jusqu'au paiement intégral de la fourniture en question.

**GARANTIE:** Nos produits sont garantis 12 mois. La garantie comprend le remplacement ou la réparation de la partie défectueuse (composant de la machine ou partie de celle-ci). Le remplacement de cette partie n'implique pas le renouvellement de la période de garantie de l'intégralité de la machine, sauf en cas de remplacement de la machine dans son intégralité. Ainsi, le constructeur n'est soumis à aucune obligation de remboursement à quelque titre que ce soit, et l'acheteur renonce à toute demande de frais ou de dommages et intérêts, même dus à un tiers, pour d'éventuels arrêt machine. La garantie ne couvre pas les pièces endommagées accidentellement durant le transport, par négligence dans les déplacements, par erreur de branchement au circuit électrique, ni les pièces sujettes à usure ou à détérioration par les agents atmosphériques et environnementaux. Toute panne dérivant d'un entretien incorrect, insuffisant ou inexistant, par inexpérience dans l'utilisation ou usage inapproprié, interdit ou non prévu, par modifications ou réparations non autorisées et altérations. La validité de la garantie dépend d'un entretien correct comme décrit aux chapitres qui traitent le sujet dans nos manuels "d'instruction et entretien" fournis avec nos produits. Le constructeur se réserve la possibilité de modifier ou améliorer les données techniques indiquées, sans que ces variations ne puisse ouvrir recours à contestation ou retour de marchandise.

**MANUEL D'INSTRUCTIONS D'UTILISATION ET D'ENTRETIEN:** Le manuel d'instruction d'utilisation et d'entretien est livré avec chaque produit. De même, le cas échéant, pour la déclaration CE de conformité. Les documents, schémas techniques et dessins inclus dans les manuels sont propriété intellectuelle et industrielle exclusives du vendeur.

**EXCLUSION DE RESPONSABILITÉ:** Le non respect des instructions imparties dans les manuels remis à la livraison du produit relève le vendeur de toute responsabilité de dommages causés aux personnes, aux animaux ou choses, que ce soit de manière directe ou indirecte.

**NORMES RÉGULATRICES:** Les cas non expressément normalisés par ces «Conditions générales de vente» relèvent des normes sur la vente conformément aux articles 1470 et selon le Code Civil Italien.

**DONNÉES PERSONNELLES:** Aux termes de l'art.13 du Décret Législatif 196/03 – Confidentialité, les données personnelles seront traitées aux fins des rapports commerciaux et de toutes les opérations nécessaires au bon déroulement des actions que nous devons entreprendre, inhérentes au contrat. Le personnel travaillant sur la gestion des rapports commerciaux est instruit en matière de protection des données personnelles et du droit à la confidentialité.

**DROIT APPLICABLE ET TRIBUNAL COMPÉTENT:** tout litige relevant de l'interprétation, l'application, l'exécution, la résolution du contrat et/ou des présentes « Conditions générales de vente » sera jugé selon le Droit Italien par le tribunal de Bergame (Italie), seul compétent.

**GENERAL SALE CONDITIONS:** The items - or groups of items - that are distinguished by the CE mark will be supplied to the member countries of the Economic European Community according to the standards stated in the regulations in force. The CE mark distinguishes the items which, according to the European regulations in force, must prove to be covered, depending on the circumstances, by certification or self-certification. As regards those countries that are not member of the European Community, the CE execution standard shall be expressly requested. Pictures, data, weights, overall dimensions and features indicated on the catalogue are not binding, as we reserve ourselves the right to introduce the necessary changes for the best operation and modernization of our products.

**ORDERS:** orders will be accepted only once the customer will receive a regular written confirmation from the seller and the validity of the prices will be that indicated on the confirmation.

**CONSIGNMENTS:** Consignments are executed at buyer's risk. They will be delivered to the forwarding-agent prescribed by the customer or failing the customer's prescription, to a forwarding-agent at our discretion, but without any responsibility from our part. The buyer, before accepting the delivery of the goods from the forwarding-agent, must check that the consignment is complete and in good condition; in case of delay, damage or loss during the carriage, any relative action towards the forwarding-agent shall be made by the buyer.

**DELIVERIES:** Delivery times are approximate. Possible delays will be communicated from the seller to the buyer. Possible delays do not constitute the right to cancel the order nor title of compensation for damages or penalties if not expressed in a written agreement.

**PAYMENTS:** Payments of invoices must be executed directly to us, without any deductions or rounding off. In case of cash payment at the receipt of invoice, the possible agreed cash discount should be calculated on the net amount of the sole material, package and possible costs for transport or delivery by post excluded. After 15 days from the date of invoice or from the period agreed previously, this benefit must be considered countermanded and the payment shall be done for the total amount of the invoice. Any failure of payment by the buyer, entitles the seller to suspend or cancel any ongoing or remaining order. For payments made later than the agreed dates, late payment interests will be due conforming with the law.

**RETENTION OF TITLE:** The products delivered by the seller to the buyer will remain property of the seller itself, until the full payment of the supplied goods.

**WARRANTIES:** Our products are covered by warranty for 12 months. The warranty involves the replacement or the repair of the faulty part (component of the machine or part of it). The replacement of this part doesn't involve the renewal of the warranty period on the whole product, except in case of replacement of the complete article. The manufacturer is therefore exonerated from each reward obligation and the purchaser renounces to every request for costs and damages also to third parties, even if the machine does not or work incorrectly. From the warranty are excluded all the parts that can be damaged accidentally during the transport, for negligence during the displacement, for the wrong connection to the electric feed line, and also the parts that are submitted to the normal wear or to deterioration due to external environmental and atmospheric causes. From the warranty are also excluded all the breakdowns due to insufficient, wrong or missing maintenance, to incompetence, to an incorrect, not allowed or not foreseen use, to not authorized modifications or replacement and to tampering. The validity of the warranty is under the correct execution of the maintenance, as described in "use and maintenance" section of the manual, following each single article. The mentioned technical details do not represent a bond for the manufacturer. The manufacturer could modify or improve the products at his discretion. Such changes could not represent reason of objections or return of goods.

**USE AND MAINTENANCE MANUAL:** With each single article made, a use and maintenance manual will be provided together with a CE-declaration of conformity, when it is due. Documents and technical schemes included in these manuals must be considered of exclusive property of the seller both intellectually and industrially.

**DISCLAIMER :** Lack of respect of the instructions given in the manuals issued upon the product delivery, relieves the seller from any responsibility of damages caused to persons, animals or objects both directly and indirectly.

**REGULATORY NORMS:** As for what not expressly disciplined by these "General Terms of Sale", the norms concerning the disciplined sale, as of the Italian Civil Code articles 1470 and following, have to be applied.

**PERSONAL DATA:** According to the art. 13 of the Legislative Decree 196/03 - privacy code, personal data will be used to allow the management of business relationships and for all those actions that are necessary for the pursuing of all the activities concerning the contract. The staff involved in the business relationships management have been duly informed concerning the protection of personal information and the right to privacy.

**APPLICABLE LAW AND JURISDICTION:** Any dispute arising from the interpretation, application, implementation and the termination of the agreement and/or of these "Terms of Sale conditions" will be disciplined by the Italian Law and exclusively devolved to the Judicial Court of Bergamo (Italy).

**PRODUCT LIABILITY:** All articles are covered by a "Product liability" insurance which is valid for a 10 years period.

**ALLGEMEINE LIEFER-UND ZAHLUNGSBEDINGUNGEN:** Die Waren bzw. Warengruppen, die durch eine CE Markierung gekennzeichnet sind, werden in die Mitgliedsstaaten der EU, konform der gültigen Verordnungen, geliefert. Die CE Markierung kennzeichnet jene Güter, die entsprechend der Anforderungen durch Zertifizierung oder Selbst-Zertifizierung ausgezeichnet sind. Auf Wunsch kann auch in Nicht-EU-Länder konform des CE -Standards geliefert werden. Die Abbildungen, technischen Daten, Gewichte und Maßangaben des Katalogs sind nicht bindend. Wir behalten uns das Recht vor, dem technischen Fortschritt dienende Änderungen durchzuführen.

**BESTELLUNGEN:** Bestellungen erfolgen ausschließlich wenn der Käufer schriftliche Bestätigung durch den Verkäufer erhalten hat und die Gültigkeit der Preise wird in die Auftragsbestätigung bezeichnet.

**LIEFERUNGEN:** Der Auftraggeber entscheidet, welcher Transportunternehmer mit dem Transport der Ware beauftragt wird. Wird uns kein entsprechender Spediteur genannt, beauftragen wir ein Speditionsunternehmen. Die Gefahr geht mit Absendung auf den Besteller über. Beanstandungen wegen unvollständiger oder falscher Lieferung sind unverzüglich mitzuteilen. Sonst gilt die Lieferung als für in Ordnung befunden. Der Besteller muss wegen des Transportunternehmers für jene Streitfrage über Lieferung schadlos halten.

**LIEFERZEITEN:** Diese versteht sich als annähernd. Lieferverzögerungen werden vom Verkäufer auf den Käufer mitgeteilt. Diese Verzögerungen geben Ihnen nicht das Recht, die Bestellung zu stornieren. Schadensersatzansprüche wegen verspäteter Lieferungen sind ausgeschlossen sofern sie nicht ausdrücklich und schriftlich ausgemacht werden.

**ZAHLUNGEN:** Die Zahlung des Rechnungsbetrages erfolgt ohne Abzüge direkt an uns. Im Falle sofortiger Zahlung nach Erhalt der Rechnung, kann ein eventuell vereinbarter Skonto nur für den Netto-Warenbetrag, ohne Verpackung, Transport- bzw. Postversandkosten gewährt werden. 15 Tage nach Rechnungsdatum oder vorab anders vereinbarter Periode, ist der Gesamt-Rechnungsbetrag ohne Skonto-Abzug fällig. Bei Nichteinhalten der Zahlungen durch den Käufer, wird den Verkäufer berechtigt anstehende oder verbleibende Bestellungen auszusetzen oder zu stornieren. Bei verspäteten Zahlungen, Verzugszinsen werden unter den Bedingungen des Gesetzes fällig.

**EIGENTUMSVORBEHALT:** Die vom Verkäufer an den Käufer gelieferten Produkte, werden Eigentum des Verkäufers bis zur vollständigen Zahlung der Warenlieferung.

**GARANTIE:** Für unsere Erzeugnisse gewähren wir 12 Monate Garantie. Die Garantie beinhaltet den Ersatz oder die Reparatur des defekten Teils (Geräte - Komponente). Der Austausch eines Geräteteils beeinflusst nicht die Garantiedauer des gesamten Gerätes, es sei denn, das komplette Gerät wird ersetzt. Der Hersteller ist darüber hinaus für jede Verpflichtung entlastet und der Käufer verzichtet auf jegliche Forderung zur Erstattung von Kosten und Entschädigungen auch an Dritten, auch wenn die Maschine nicht oder nicht richtig arbeitet. Von der Garantie ausgeschlossen sind alle Teile, die durch unsachgemäßen Transport / Montage, durch falsches Anschließen am vorhandenen elektrischen Netz, durch nicht fachgerechtes Versetzen, unzulässige oder nicht dem Betriebszweck dienende Veränderungen sowie externe Umgebungs- und Wetter- Einflüsse beschädigt wurden. Garantie kann nur gewährt werden, wenn die Maschinenwartung durchgeführt wurde, wie beschrieben in jeder den Geräten beigefügten Bedienungsanleitung (siehe die "Gebrauch und Wartung" Abschnitt). Der Hersteller behält sich das Recht technischer Änderung/Verbesserungen des Produktes ohne vorherige Benachrichtigung des Kunden vor. Diese Änderung/Verbesserungen stellen keinen Grund zum Rücktritt vom Kauf des Artikels dar.

**BEDIENUNGSANLEITUNG:** Gemeinschaftlich mit jedem hergestellten Produkt wird eine Bedienungsanleitung mit einer EG-Konformitätserklärung (wo es benötigt ist) ausgeliefert. Geschäftsunterlagen, Technisches Datenblatt sowie Technische Zeichnungen die in diesen Bedienungsanleitungen enthalten sind, sind geistiges sowie gewerbliches Eigentum des Verkäufers.

**IMPRESSUM:** Die Nichtbeachtung der Anweisungen, die in die bei der Lieferung gelieferte Bedienungsanleitungen beschrieben sind, entheben den Verkäufer von jeder Verantwortung für Schäden an Personen, Tieren oder Sachen, ob direkt oder indirekt.

**VORSCHRIFTEN:** Sofern nicht ausdrücklich in diesen „Geschäftsbedingungen“ geregelt ist, gelten die Normen des italienischen Zivilgesetzbuches ab den Artikelnummer 1470 in Bezug auf den Verkauf von Waren.

**PERSÖNLICHE DATEN:** Gem. Artikel 13 des Dekrets 196/03 - Datenschutzkodex, die Verarbeitung von Daten wird gemacht, um den Management der Geschäftsbeziehungen und die Maßnahmen, die für die Durchführung der Aktivitäten inhärent den Vertrag die wir ausüben werden zu verwalten. Das Personal, das in der Verwaltung von Geschäftsbeziehungen einbezogen ist, ist über den Schutz der persönlichen Daten und über das Recht auf Achtung der Privatsphäre geschult.

**ANWENDBARES RECHT UND GERICHTSSTANDS:** Jede beliebige Streitigkeit, die sich aus der Auslegung, Handhabung, Abwicklung, Wandelung und/oder aus dieser „Geschäftsbedingungen“, werden durch das italienische Gesetz geregelt. Als zuständiger Gerichtsstand wird ausschließlich das Gericht Bergamo (Italien) vereinbart.

**PRODUKTHAFTUNG:** Alle Produkte sind durch eine Versicherung gedeckt, die für einen Zeitraum von 10 Jahren gültig ist.



ART.	PAG.	ART.	PAG.	ART.	PAG.	ART.	PAG.	ART.	PAG.	ART.	PAG.
001	322	041	323	099/B	224	115	194	143	169	163/R	314
002	322	041/A	323	15/73	164	116	194	146/M	278	163/W	312
002/A	322	042	323	100	255	117	194	147	279	164	310
010	322	042/A	323	100/A	255	118	194	147/A	279	164/R	314
011	322	043	323	100/B	255	118/A	194	149/M	280	164/RP	318
011/A	322	043/A	323	100/C	255	119	196	151	212	164/RPA	318
012	322	044	323	100/D	255	119/A	196	152	300	164/RS	314
012/A	322	044/A	323	101	251	120	196	153	301	164/W	312
013	322	045	323	102	251	120/A	196	154	302	164/WM	320
014	322	050	325	102/EXPORT	252	122	198	154/E	302	164/WS	312
014/A	322	051	325	105	252	122/A	198	154/IP	306	196	141
015	322	052	325	106/A	258	123	198	154/ML	310	196/A	141
020	326	053	325	106/B	258	123/A	198	154/MR	314	196/B	142
021	326	060	325	106/B1	258	124	198	154/P	308	196/MS	137
022	326	061	325	108	256	125	180	155	302	196/MS-SP	137
022/A	326	062	325	108/A	256	125/A	180	155/IP	306	196/NS	137
022/B	326	070	325	109/A	222	126	180	155/P	308	196/OS	138
022/C	326	071	325	109/AS	222	126/A	180	156	302	196/OSL	139
022/D	326	072	325	109/B	222	126/B	180	156/IP	306	196/OSL-SP	139
030	322	073	325	109/BS	222	127	180	156/ML	310	196/P	136
031	322	080	325	109/C	222	127/A	180	156/MR	314	196/PI	136
031/A	322	081	325	109/CS	222	128	180	156/P	308	196/PL	136
031/B	322	082	325	110	212	129	180	156/W	312	196/PL-SP	136
032	322	083	325	110/A	212	129/A	180	157	304	199/ALFA	24
032/A	322	084	325	110/B	212	130	182	157/IP	306	199/BETA	15
033	322	090	324	110/C	212	130/A	182	158	304	199/DELTA	14
034	322	090/A	324	111	217	130/B	184	158/IP	306	199/DK	22
034/A	322	090/B	324	111/A	219	131	264	159	304	199/GAMMA	23
035	322	090/C	324	111/B	219	132	264	160	304	199/GK	22
036	322	090/D	324	112	192	133	264	161	310	199/R	18
037	322	090/E	324	112/A	192	134	264	161/R	314	199/RL	18
038	321	092	225	112/B	192	135	268	161/W	312	199/RX	20
038/A	321	095	225	112/C	192	136	268	162	310	199/RY	20
038/B	321	095/A	225	112/D	192	137	268	162/R	314	199/T	12
040	321	096	258	112/XR	208	138	268	162/W	312	199/TE	13
040/A	321	096/A	258	113	194	138/A	268	162/WM	320	199/U	12
040/B	321	099	224	114	194	141	168	163	310	199/UE	13

ART.	PAG.	ART.	PAG.	ART.	PAG.	ART.	PAG.	ART.	PAG.	ART.	PAG.
199/V	34	218	214	267	204	306	247	359/CM	289	362/A	288
199/W	34	219	218	274	234	307	247	359/D	289	362/AM	288
199/WL	37	222	270	274/A	235	316	248	359/DM	289	362/B	289
199/WRL	35	222/A	271	275	233	318	248	359/EM	290	362/BM	289
199/WRX	35	223/M	280	275/A	233	321	257	359/FM	290	362/C	289
199/X	34	227	172	276	242	322	257	359/GM	290	362/CM	289
199/YL	32	227/A	174	277	242	323	248	359/HM	290	362/D	289
199/YP	33	227/B	176	277/A	242	324	256	359/M	288	362/DM	289
203	154	227/BI	176	278	242	325	247	360	288	362/EM	290
204/R	314	234	164	279	243	325/A	247	360/A	288	362/FM	290
204/RE	314	239	215	279/A	243	325/B	247	360/AM	288	362/GM	290
204/RP	318	239/A	215	280	243	325/C	247	360/B	289	362/HM	290
204/RPA	318	240	215	280/A	243	350/A	295	360/BM	289	362/M	288
204/W	312	241	215	280/R	316	350/C	256	360/C	289	363	288
204/WE	312	241/A	215	280/W	316	350/D	257	360/CM	289	363/A	288
204/WM	320	242	215	281	243	350/E	257	360/D	289	363/AM	288
205/R	316	243	170	281/A	243	351	257	360/DM	289	363/B	289
205/W	316	243/A	170	282	243	353	253	360/EM	290	363/BM	289
206/M	278	250	232	282/A	243	355	254	360/FM	290	363/C	289
207	224	250/A	232	283	244	357	296	360/GM	290	363/CM	289
208	223	250/B	232	285	244	357/A	296	360/HM	290	363/D	289
208/S	223	251	242	290	258	357/B	296	360/M	288	363/DM	289
209	223	252	200	295/SP	245	357/C	296	361	288	363/EM	290
209/S	223	253	200	296/SP	245	357/D	296	361/A	288	363/FM	290
210	224	254	200	297	244	358/A	295	361/AM	288	363/GM	290
211	223	255	200	299/B	244	358/B	295	361/B	289	363/HM	290
211/A	223	256	200	299/D	244	358/C	295	361/BM	289	363/M	288
212	225	257	202	299/H	245	358/D	295	361/C	289	364/AM	291
213	226	258	202	299/M	245	358/E	295	361/CM	289	364/BM	291
214	226	259	202	299/N	245	358/K	295	361/D	289	364/M	291
214/A	226	260	202	299/O	245	358/L	295	361/DM	289	365/AM	291
214/B	226	261	202	300	247	359	288	361/EM	290	365/BM	291
214/C	226	262	202	301	247	359/A	288	361/FM	290	365/M	291
214/D	226	263	202	302	247	359/AM	288	361/GM	290	366	293
215	213	264	202	303	247	359/B	289	361/HM	290	366/A	293
216	213	265	204	304	247	359/BM	289	361/M	288	366/B	293
217	214	266	204	305	247	359/C	289	362	288	367	293

ART.	PAG.	ART.	PAG.	ART.	PAG.	ART.	PAG.	ART.	PAG.	ART.	PAG.
367/A	293	390/A	336	454	106	711/E	65	811	78	826/I+853/A	82
367/B	293	390/B	336	454/A	106	711/F	65	811+853/B	78	835	76
367/C	293	392/A	192	458/A	157	711/G	65	812	78	835/I	76
367/H	294	392/B	192	458/B	156	713	65	812+853/B	78	840	82
367/I	294	392/C	194	458/C	157	714	64	813	80	840/I	82
367/N	294	392/D	196	459	152	714/A	64	813+853/B	80	845	85
367/O	294	393	244	459/A	153	714/B	64	814	76	845/A	85
367/R	294	396	337	460	155	714/C	64	814+853/B	76	846	84
367/S	294	399	98	540/A	70	715	64	815	82	847	85
368/AM	291	400	98	541	68	715/A	64	815+853/B	82	847/A	85
368/BM	291	400/C	100	541/IP	68	715/B	64	815/A	82	847/B	85
368/CM	291	400/L	98	542	69	715/C	64	815/A+853/B	82	847/C	85
368/DM	291	401	98	550	71	715/D	64	820	76	847/D	85
368/M	291	401/C	100	550/A	71	715/E	64	820+853/A	76	847/E	94
369	292	401/CSAI	100	551	62	718	56	820/I	76	847/F	94
369/A	292	401/I	98	551/I	62	718/M	58	820/I+853/A	76	848	84
369/D	292	401/L	98	552	60	719	56	821	78	850	148
369/E	292	401/LS	98	553	60	719/M	58	821+853/A	78	850/I	148
369/H	292	402/L	100	560	144	725/A	65	821/I	78	852	85
369/I	292	402/LS	100	560/A	144	725/B	65	821/I+853/A	78	852/A	85
370	25	403	102	561	143	730	54	822	78	852/B	85
370/A	25	403/C	102	562	143	800	76	822+853/A	78	852/C	92
370/B	25	403/CSAI	102	562/A	143	800+853/B	76	822/I	78	852/D	92
370/C	25	403/LS	102	563	145	801	78	822/I+853/A	78	852/E	92
370/D	25	403/LSI	102	563/A	145	801+853/B	78	823	80	855	148
371	28	405	111	563/B	145	802	78	823/I	80	855/I	148
372	28	406	111	566	144	802+853/B	78	824	76	856	86
373	28	407	111	600	224	803	80	824+853/A	76	856/A	105
379	236	441	104	610	246	803+853/B	80	824/I	76	857	92
381	236	441/A	104	703	52	804	76	824/I+853/A	76	860	90
381/A	236	442	104	703/A	52	804+853/B	76	825	82	860/I	90
388	238	442/A	104	705	52	805	82	825+853/A	82	861	90
388/A	240	450	154	705/M	52	805+853/B	82	825/I	82	861/I	90
388/B	171	450/A	155	711	65	805/A	82	825/I+853/A	82	862	90
388/C	237	453	106	711/A	65	805A+853/B	82	826	82	862/I	90
388/SW	239	453/A	106	711/B	65	810	76	826+853/A	82	863	90
389/A	334	453/B	112	711/C	65	810+853/B	76	826/I	82	863/I	90

ART.	PAG.	ART.	PAG.	ART.	PAG.	ART.	PAG.	ART.	PAG.	ART.	PAG.
864	90	926	122	1003/PL	227	A199/R	26	P30/SAP	308	SL/30	266
864/I	90	930	216	1004	227	A459	152	P30/W	312	STRONG EXPORT	260
865	90	950	149	1004/PL	227	A552	65	PLUS	85	STRONG MAJOR/R	260
865/I	90	950/I	149	1011	228	A730	64	PM/1	297	TP/1	284
866	90	952	124	1050	228	B199/R	26	PM/2	297	TP/2	284
866/I	90	953	124	1051	228	B730	64	RAPID T10 A	284		
900	116	953/A	124	1052	228	BA/1	297	RAPID T10 A/M	285		
901	116	953/B	124	1053	228	BA/2	297	RAPID T10 B	284		
902	116	959	126	1070	228	BA/3	297	RAPID T10 B/M	285		
903	116	959/A	126	1071	228	BA/4	297	RAPID T10 C	284		
906	118	959/B	126	1072	228	BA/5	297	RAPID T10 C/M	285		
907	118	963	126	1073	228	C51	229	RAPID T10 D	284		
908	118	963/A	126	1074	228	C51/A	229	RAPID T10 D/M	285		
910	116	963/B	126	1075	228	C52	229	RAPID T10 E	284		
910/SM	117	982	132	1076	228	C53	230	RAPID T10 E/M	285		
910+910	120	982/A	132	1077	228	C54	230	RAPID T10 F	284		
911	116	982/B	132	1100	222	C55	230	RAPID T10 F/M	285		
911+911	120	983	130	1108	224	C199/R	26	RAPID T10 G	284		
912	116	983/A	130	1120/E	206	CM	251	RAPID T10 G/M	285		
912+912	120	983/B	130	1120/F	206	CPT	251	RAPID T10 MINI	284		
913	116	983/FM	130	1120/G	206	D199/R	26	SIF1/73	160		
913+913	120	984	130	1130/XR	209	E199/R	26	SIF1/A/73	160		
916	118	985	131	2002	46	G199/R	26	SIF2/73	160		
917	118	985/A	131	2005	47	GP05/DE	272	SIF2/A/73	160		
918	118	995	128	2005/L	47	GP05/S	272	SIF3/73	160		
920	122	995/A	128	3000	186	GP10/DE	272	SIF4/73	160		
921	122	995/B	128	3010	186	GP10/S	272	SIF5/73	160		
921/A	122	995W	128	3020	188	GP12/DE	274	SIF5/73 IP	163		
921/B	122	995W/A	128	3030	188	H199/R	26	SIF6/73	161		
921/C	122	995W/B	128	3100IP	190	N199/RX	27	SIF6/73 IP	163		
922	122	1000	227	5000	338	K/012	200	SIF7/73	162		
922/A	122	1000/PL	227	5000/M	338	M/1	297	SIF8/73	162		
922/B	122	1001	227	5001	338	M/2	297	SIF10/73	162		
922/C	122	1001/PL	227	5001/M	338	P30/ML	310	SIF/XR	165		
922/D	122	1002	227	5002	338	P30/MR	314	SIF/XR IP	166		
923	122	1002/PL	227	5002/M	338	P30/SA	304	SL/15	266		
923/A	122	1003	227			P30/SAIP	306	SL/20	266		















**24020 VILLA DI SERIO (BG) ITALY**

Via Divisione Tridentina, 23  
T. 035 4234411 • F. 035 4234441  
[www.omcn.it](http://www.omcn.it) • [info@omcn.it](mailto:info@omcn.it)

**EXPORT**

T. +39 035 4234416 • F. +39 035 4234449  
[www.omcn.com](http://www.omcn.com) • [info@omcn.com](mailto:info@omcn.com)