

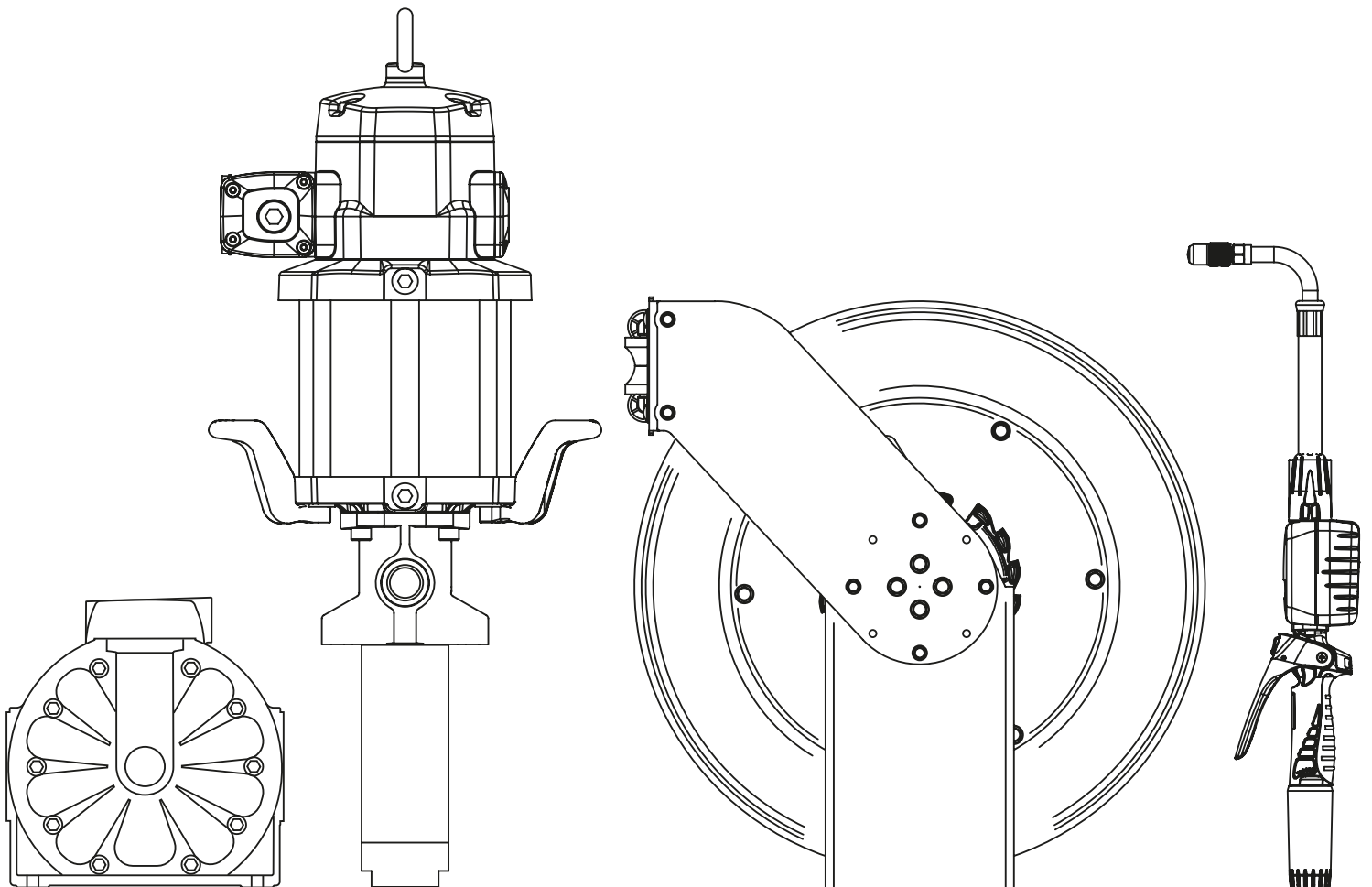

PRODUCT CATALOGUE

LUBRICATION EQUIPMENT

AUTOMOTIVE • PETROLEUM • INDUSTRIAL





Headquarters Offices and Technical Centre in Gijón (Spain)

SAMOA QUALITY AND LEADERSHIP

FLUID HANDLING TECHNOLOGY

SAMOA, a privately owned company, is a leading European manufacturer of Lubrication and Fluid Handling Equipment. SAMOA products are used for transfer, dispensing, dosing and recovery. SAMOA designs and manufactures a wide program that includes air operated piston and diaphragm pumps, volume flow meters, delivery guns, electronic components for inventory control systems, hose reels, hand pumps and accessories.

PRODUCT DEVELOPMENT

Product research and development is a fundamental part of SAMOA's philosophy. We are in permanent contact with the market to identify new customer needs, that we satisfy with product improvements and new products.

MANUFACTURING

SAMOA's headquarters have been in Gijón, on the Spanish North Coast, for over 55 years. SAMOA's manufacturing facilities are modern and are equipped with the latest state-of-the-art production equipment and technology. We are committed to design and manufacturing excellence, environmental sustainability and a healthy and safe workplace; our work processes and facilities are consequently ISO 9001, ISO 14001 and OHSAS 18001 certified.

DISTRIBUTION

Our products are available through a network of knowledgeable distributors and owned Distribution Companies. This global network provides a sales and consulting service, to identify the products that best meet each customer's needs and, when required, offers after sales service to ensure the long and satisfactory use of our equipment.

GLOBALLY COMPETITIVE

Our continuous product improvement process ensures that our products meet customer requirements worldwide, including in even the most demanding applications and environments. As a result, we are proud to say that SAMOA products are reliably working away, night and day, in more than 100 countries.



Research & Development and Manufacturing facility in Gijón (Spain)



SAMOA QUALITY AND LEADERSHIP



RESEARCH AND DEVELOPMENT

SAMOA's R&D Department is at the cutting edge of Lubrication Equipment and Fluid Handling product developments program with innovative technology concepts.

PRODUCT DESIGN & ENGINEERING

Product designs are created and rough product engineering is ensured by using 3D CAD. CAD-CAM manufacturing equipment dedicated to prototyping and a well equipped test laboratory, allow fast product evolution and the release to market of optimized and fully proven products.



STATE OF THE ART MANUFACTURING

High volume CNC manufacturing equipment is fed by robots. The robotized material handling processes incorporate part cleaning and 100% automated part inspection.

Sheet metal processing is also highly automated and it includes welding robots, laser cutting and CNC bending machines among others.



COMPONENTS FINISHING

Once components are manufactured and passed inspection procedures, they are finished before they are assembled into final products.

Products are polyester powder coated, zinc or nickel plated depending on their functionality and finishing requirements.



UNWAVERING COMMITMENT TO QUALITY

Components are inspected during their manufacturing process following SPC standard and many sub-assemblies are 100% functionally tested. Many products, including all air operated pumps and meters, are run wet and taken through a carefully defined test procedure to ensure zero defects on shipment.

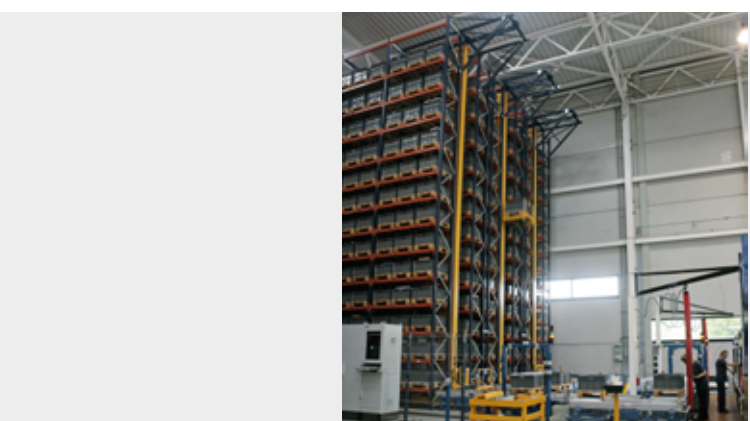

RAPID AND RELIABLE ORDER FULFILMENT

SAMOA's experienced customer service staff and worldwide distributors can recommend the Lubrication Equipment System that best meets each application's need.

A generous inventory of finished products and parts allows short delivery times. High rotation products are stored in an automated warehouse integrated with the ERP system.

Prompt after-sales service and immediate spare parts availability ensure a long and trouble-free product life.

INDEX

01 AIR OPERATED OIL PUMPS AND KITS



01

OIL PUMPS

AIR OPERATED OIL PUMPS	6
PUMPMASTER 2 - 1:1 RATIO OIL PUMPS	8
PUMPMASTER 2 - 3:1 RATIO OIL PUMPS	10
PUMPMASTER 2 ACCESSORIES, OTHER OIL MOBILE DISPENSERS	13
PUMPMASTER 4 - 3:1 RATIO OIL PUMPS	14
PUMPMASTER 4 - 5:1 RATIO OIL PUMPS	15
PUMPMASTER 4 - 8:1 RATIO OIL PUMPS	16
PUMPMASTER 4 - 3:1 AND 5:1 OIL PUMPS INSTALLATION KITS AND ACCESSORIES	17
PUMPMASTER 45 - 3:1 RATIO OIL PUMP	19
PUMPMASTER 45 - 6:1 RATIO OIL PUMP	20
PUMPMASTER 45 - 10:1 RATIO OIL PUMPS	21
PUMPMASTER 60 - 6:1 RATIO OIL PUMP	22
PUMPMASTER 60 - 12:1 RATIO OIL PUMP	23
PUMPMASTER 45 AND 60 ACCESSORIES	24
OIL PUMP ACCESSORIES	25

02 AIR OPERATED GREASE PUMPS AND KITS



02

GREASE PUMPS

AIR OPERATED GREASE PUMPS	28
PUMPMASTER 3 - 55:1 RATIO GREASE PUMPS	30
PUMPMASTER 3+3 - 60:1 RATIO GREASE PUMPS	32
PUMPMASTER 3 AND PUMPMASTER 3+3 ACCESSORIES	35
PUMPMASTER 45 - 25:1 RATIO GREASE PUMP	37
PUMPMASTER 45 - 40:1 RATIO GREASE PUMPS	38
PUMPMASTER 45 - 70:1 RATIO GREASE PUMPS	39
PUMPMASTER 60 - 12:1 RATIO GREASE PUMP	40
PUMPMASTER 60 - 80:1 RATIO GREASE PUMPS	41
PUMPMASTER 45 & 60 INSTALLATION KITS	42
PUMPMASTER 45 & 60 GREASE PUMP KITS	43
GREASE PUMP ACCESSORIES	45

03 AIR OPERATED PUMPS FOR OTHER SERVICE FLUIDS



03

OTHER FLUIDS PUMPS

AIR OPERATED DIAPHRAGM PUMPS	48
DIAPHRAGM PUMPS ACCESSORIES	53
AIR OPERATED PISTON PUMPS FOR FLUIDS	54

04 HOSE REELS

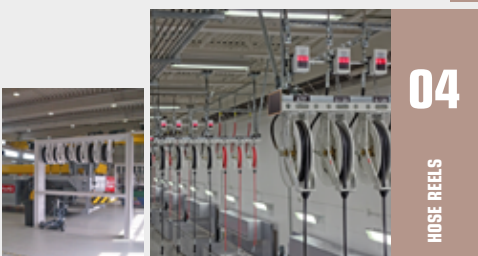

04

HOSE REELS

HOSE REEL MOUNTING RECOMMENDATIONS	57
RM-12 DOUBLE PEDESTAL DOUBLE ARM HOSE REELS	58
RM-12US ULTRA SLIM ENCLOSED HOSE REELS	59
RM-12S SINGLE ARM ALUMINIUM HOSE REELS	60
RM-12CL INDIVIDUALLY ENCLOSED HOSE REELS	61
RM-12L HEAVY DUTY HOSE REELS	62
RM-34 HEAVY DUTY HOSE REELS	63
RM-100 HEAVY DUTY LARGE CAPACITY HOSE REELS	64
RM-150 HEAVY DUTY LARGE DELIVERY HOSE REELS	65
COMPACT REELS FOR AIR AND CABLE	66
HOSE REEL ACCESSORIES	67

INDEX

05 FLUID DISPENSE VALVES AND METERS



05

VALVES AND METERS

CONTROL VALVES FOR DISPENSING OIL AND OTHER FLUIDS	70
ELECTRONIC METERED CONTROL VALVES FOR DISPENSING OIL AND OTHER FLUIDS	72
MECHANICAL METERED CONTROL VALVES FOR DISPENSING OIL AND OTHER FLUIDS	74
MECHANICAL METERED PRESET CONTROL VALVES FOR DISPENSING OIL AND OTHER FLUIDS	75
IN-LINE METERS	76
PULSE TRANSMITTERS	77
OTHER METERS AND ACCESSORIES	78
GREASE GUNS AND ACCESSORIES	79
OIL BARS, SPIGOT VALVES AND OTHER FLUID DISPENSE GUNS	80

06 INVENTORY MANAGEMENT SYSTEMS

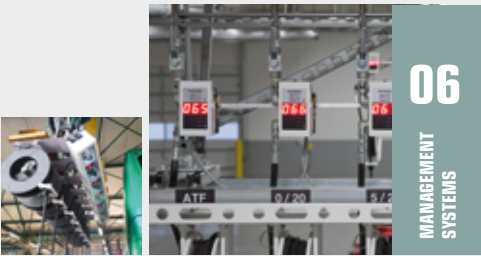

06

MANAGEMENT SYSTEMS

ADVANCED MONITORING SYSTEM	82
ADVANCED MONITORING SYSTEM. BASIC COMPONENTS	84
ADVANCED COMMUNICATION PLATFORM AND ACCESSORIES	85
TANK LEVEL CONTROL SOLUTIONS	86
INVENTORY MANAGEMENT CONSOLE	88
SPECIAL AMS VERSION	89
PRESET DOSING MODULE	90

07 WASTE OIL EQUIPMENT



07

WASTE OIL

USED FLUID COLLECTION UNITS	92
WASTE OIL SUCTION AND GRAVITY RECEIVERS, 100 AND 70 LITRES	93
WASTE OIL DRAIN UNITS	94
WASTE OIL EVACUATION PUMP KITS	95
WASTE OIL EQUIPMENT ACCESSORIES	96

08 ELECTRIC PUMPS



08

ELECTRIC PUMPS

DC DIESEL PUMPS AND KITS - POLUX SERIES	98
AC DIESEL PUMPS AND KITS - POLARIS SERIES	99
DIESEL PUMP ACCESSORIES	101
AdBlue®/DEF PUMPS AND KITS - SOLURA SERIES	102
AdBlue®/DEF PUMPS ACCESSORIES	103
OIL PUMPS AND KITS WITH ELECTRIC MOTOR - FLOWSTAR SERIES	104

09 LUBRICATION TOOLS AND ACCESSORIES



09

LUBRICATION TOOLS

GREASE NIPPLES	108
GREASE CONNECTORS	110
LEVER ACTION GREASE PUMPS	111
MANUAL HAND HELD GREASE PUMPS	112
AIR OPERATED AND BATTERY HAND HELD GREASE PUMPS, FILLER PUMPS AND FITTINGS	113
GREASE COMPRESSORS AND BUCKET PUMPS	114
DRUM PUMPS FOR OIL	115
DRUM PUMPS FOR VARIOUS FLUIDS	116
FUNNELS, MEASURES, GRAVITY COCKS, JERRY CANS AND OIL SUCTION PUMPS	117
AIR TREATMENT UNITS (FRLS)	118
AIR COUPLERS AND CONNECTION ADAPTORS FOR COMPRESSED AIR	119

10 PART NUMBER INDEX

PART NUMBER INDEX	121
-------------------	-----

AIR OPERATED OIL PUMPS	6
PUMPMASTER 2 - 1:1 RATIO OIL PUMPS	8
PUMPMASTER 2 - 3:1 RATIO OIL PUMPS	10
PUMPMASTER 2 ACCESSORIES, OTHER OIL MOBILE DISPENSERS	13
PUMPMASTER 4 - 3:1 RATIO OIL PUMPS	14
PUMPMASTER 4 - 5:1 RATIO OIL PUMPS	15
PUMPMASTER 4 - 8:1 RATIO OIL PUMPS	16
PUMPMASTER 4 - 3:1 AND 5:1 OIL PUMPS INSTALLATION KITS AND ACCESSORIES	17
PUMPMASTER 45 - 3:1 RATIO OIL PUMP	19
PUMPMASTER 45 - 6:1 RATIO OIL PUMP	20
PUMPMASTER 45 - 10:1 RATIO OIL PUMPS	21
PUMPMASTER 60 - 6:1 RATIO OIL PUMP	22
PUMPMASTER 60 - 12:1 RATIO OIL PUMP	23
PUMPMASTER 45 AND 60 ACCESSORIES	24
OIL PUMP ACCESSORIES	25



AIR OPERATED OIL PUMPS

It all starts with the pump; the heart of the system. The choice of a pump requires considering a wide variety of factors so that your system will provide years of dependable service. SAMOA has engineered a broad offering of oil pumps to handle a wide variety of applications. This range of pumps will fit original containers of different sizes and bulk storage tanks; covering applications that range from the transfer of oil to very large centralized systems.

WHY CHOOSE AN AIR OPERATED PUMP?

Compressed air provides the best power source because it allows the pump to stall against fluid back pressure. When the dispense gun is opened, the fluid pressure drops in the system, the pump automatically starts and oil flows. When the dispense gun is closed, back pressure is created in the system. When the fluid back pressure force acting on the pump piston equals the force of the compressed air pushing on the pump air piston, the system stops or stalls. When using other power sources, such as electric or hydraulic, the pump must have pressure sensing switches, bypass loops and relief valves, for controlling the motor and pressure.

PRESSURE AND VOLUME

An important, and often confusing, aspect of selecting a pump is how to determine which pump ratio and what pump size to select. The pump ratio is calculated by dividing the surface area of the air motor piston by the surface area of the fluid piston. The maximum pressure at the pump outlet that the pump is able to develop is determined multiplying the air inlet pressure by the pump pressure ratio. Restrictions such as the pipe length and diameter, hoses, hose reels, solenoid valves, pulse meters, control handles, and other system components create friction in the system. Sufficient fluid pressure is needed to overcome this friction, in order to get the required volume of oil to each dispense point.

Pump size determines the amount of fluid flowing through the piston pump outlet during each cycle of the pump. Three different sizes of pumps, with the same ratio, will each deliver a different flow rate. It is important to consider a variety of factors (number of dispense points, desired delivery, product dispensed,...) in choosing the proper pump size for your system.

PUMP MASTER®



	PUMPMASTER 2 - 1:1	PUMPMASTER 2 - 3:1	PUMPMASTER 4 - 3:1	PUMPMASTER 4 - 5:1
PUMP DESCRIPTION	Utility Transfer	Utility Medium Pressure	Standard Duty Medium Pressure	Standard Duty Medium Pressure
SIMULTANEOUS OPERATION OUTLETS	1 (no reels)	1	1 to 2	1 to 2
MAX. LINE LENGTH	30 m - 100'	60 m - 200'	60 m - 200'	150 m - 500'
APPLICATION	Service shops In-plant oil transfer Agriculture Marine	Auto dealers Service shops Fast lube centres Agriculture Marine	Auto dealers and service shops Fleet service Fast lube centres Lube trucks Mining and construction In-plant	Auto and truck dealers Fleet service Mining and construction Lube trucks Railroad and mass transit Marine In-plant

Maximum line length and number of simultaneous dispense outlets also depends on the line diameter, fluid viscosity and required delivery.

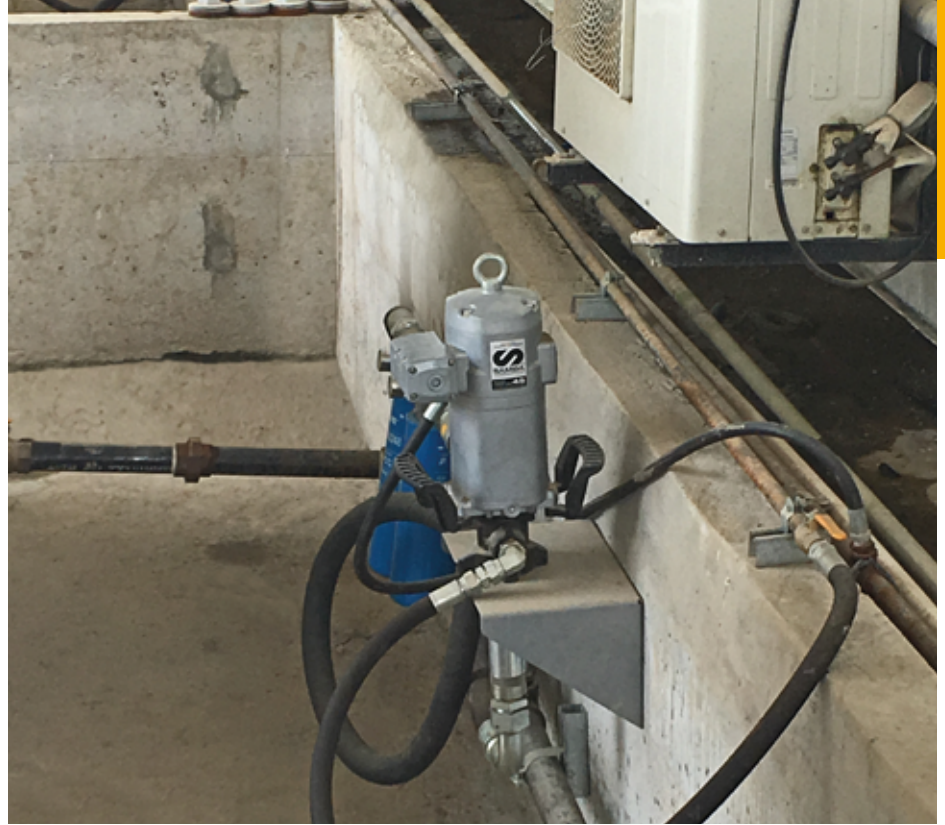

PUMPMASTER 45 - 3:1	PUMPMASTER 45 - 6:1	PUMPMASTER 45 - 10:1	PUMPMASTER 60 - 6:1	PUMPMASTER 60 - 12:1
Intensive Duty Volume Transfer	Intensive Duty High Flow	Intensive Duty Pressure Flow	Intensive Duty High Delivery	Intensive Duty High Performance
3 to 4	3 to 4	3 to 4	3 to 4	3 to 4
75 m - 250'	160 m - 525'	240 m - 800'	160 m - 525'	250 m - 800'
Construction equipment Mining equipment Large fleets Railroad and mass transit Marine In-plant oil distribution	Large auto and truck dealers Construction equipment Mining equipment Railroad and mass transit Large fleets Lube trucks Marine In-plant oil distribution	Large auto and truck dealers Construction equipment Mining equipment Railroad and mass transit Large fleets Lube trucks Marine In-plant oil distribution	Very large auto and truck dealers Construction equipment Mining equipment Large fleets Railroad and mass transit Marine In-plant oil distribution	Very large auto and truck dealers Construction equipment Mining equipment Large fleets Railroad and mass transit Marine In-plant oil distribution

Maximum line length and number of simultaneous dispense outlets also depends on the line diameter, fluid viscosity and required delivery.

351 120

UTILITY TRANSFER PUMPS

Double acting air operated low pressure pumps for transferring lubricants. Pumps include height adjustable 2" BSP (M) bung adaptor for tank or drum bung mounting. Built in port for optional pressure relief valve (PN 609 007).



FLUIDS HANDLED

- Synthetic and mineral based lubricants.
- Transmission fluid.
- Hydraulic oil.
- Diesel.

MARKETS SERVED

- Service shops.
- In plant oil transfer.
- Agriculture.
- Marine.
- Mining and construction.

MODELS				
PART No.	APPLICATION	PUMP TUBE HEIGHT	TOTAL HEIGHT	WEIGHT
351 120	Universal stub pump	215 mm	500 mm	2,5 kg
356 120	60 l (16 gal) drum bung mounted	725 mm	985 mm	4,8 kg
352 120	205 l (55 gal) drum bung mounted	915 mm	1.200 mm	5,4 kg

TECHNICAL DATA	
Pump pressure ratio	1:1
Air pressure operating range	1,5 - 10 bar (20 to 140 psi)
Air consumption ⁽¹⁾	150 NL/min (5.3 cfm)
Maximum fluid outlet pressure	10 bar (140 psi)
Air motor diameter	51 mm (2")
Air motor effective diameter	35 mm (1.4")
Air motor stroke	75 mm (3")
Delivery at 150 cpm	20 l/min (5.3 US gpm)
Maximum free flow delivery ⁽²⁾	52 l/min (13,7 US gpm)
Air inlet	1/4" BSP (F)
Fluid inlet (short pump only)	1" BSP (F)
Fluid outlet	3/4" BSP (F)
Wetted and seal materials	Aluminium / Steel / NBR / Acetal / Polyurethane
Noise level ⁽³⁾	80 dB

(1) Air consumption with 6 bar air inlet pressure and 150 cycles per minute.

(2) Maximum free delivery at 7 bar.

(3) Maximum noise level measured at 1 m from the pump, 7 bar air pressure and free delivery.

SAE 30 - 20 °C (68 °F) CAPACITY

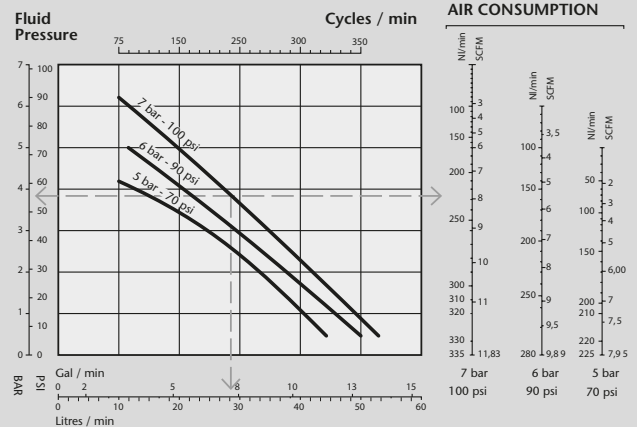

DIMENSIONS (mm)			
MODEL	351 120	356 120	352 120
A (mm)	500	985	1.200
B (mm)	285	285	285
C (mm)	52	52	52
D (mm)	215	700	915

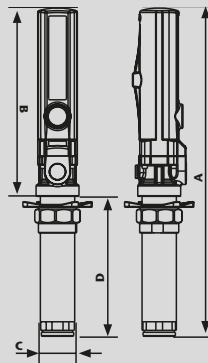

PUMPMASTER 2 - 1:1 PUMP PACKAGES FOR 205 LITRE DRUMS

Packages with air operated low pressure transfer pump. The pump is designed to fit through the 2" bung opening on 50 and 205 l oil drums or to be mounted on a lid for open drums. The pump is fixed using a height adjustable bung adapter.

1:1 ratio pumps are used for a clean and efficient transfer of lubricants, from their original drum to miscellaneous portable grease and oil pumps, buckets, auxiliary tanks, etc., without the risk of lubricant contamination.

An air valve or an optional pressure regulator allows the user to adjust the pump speed and the lubricant flow rate. This is useful when filling open buckets to prevent splashing or to avoid overflow when reaching the top of a container.

454 002

454 003

454 010

454 009



PART NO.	DESCRIPTION	APPLICATION	PUMP	HOSE	DELIVERY GUN	AIR INLET ACCESSORY	APPROX.. DELIVERY
454 002	1:1 high volume transfer package	205 l drums	352 120	3 m x 3/4" 362 303	High delivery nozzle 361 000	Needle air valve 950 302	30 l/min ⁽¹⁾
454 003	1:1 transfer package	205 l drums	352 120	3 m x 1/2" 362 103	Oil control gun 363 115	–	15 l/min ⁽¹⁾
454 010	1:1 transfer package, metered	205 l drums	352 120	3 m x 1/2" 362 103	Hose end meter 365 535	–	10 l/min ⁽¹⁾
454 009 ⁽³⁾	1:1 grease transfer package	185 kg drums	352 120	3 m x 3/4" 362 303	Ball valve with angled nozzle	Needle air valve 950 302	3,2 kg/min ⁽²⁾

(1) Delivery with SAE30 oil at 7 bar inlet pressure and 20 °C temperature.

(2) Delivery with NLG12 grease at 7 bar inlet pressure and 20 °C temperature.

(3) Model 454 009 also includes drum cover PN 418 006 and follower plate PN 417 004 for 185 kg grease drums.

Not included options:

239 000: 1/4" BSP (MM) connection adaptor.

240 200: Air pressure regulator 0 - 12 bar, 1/4" BSP (FF)

240 500: Air filter and pressure regulator, 0 -12 bar, 1/4" BSP (FF).

PUMPMASTER 2 - 3:1 RATIO OIL PUMPS

354 120

UTILITY MEDIUM PRESSURE PUMPS

Double acting air operated medium pressure pumps for dispensing lubricants from mobile units, oil distribution packages and small systems. Pumps include 2" BSP (M) height adjustable bung adaptor for tank or drum bung mounting. Built in port for optional pressure relief valve (PN 609 007).



FLUIDS HANDLED

- Synthetic and mineral based lubricants.
- Hydraulic oil.
- Gear oil.
- Transmission fluid.

MARKETS SERVED

- Auto dealers.
- Service shops.
- Fast lube centres.
- Agriculture.
- Marine.
- Mining and construction.

MODELS				
PART No.	APPLICATION	PUMP TUBE HEIGHT	TOTAL HEIGHT	WEIGHT
353 120	Universal stub pump	200 mm	495 mm	2 kg
358 120	60 l (16 gal) drum bung mounted	700 mm	995 mm	3 kg
354 120	205 l (55 gal) drum bung mounted	905 mm	1.200 mm	3,5 kg

TECHNICAL DATA	
Pump pressure ratio	3:1
Air pressure operating range	1,5 - 10 bar (20 to 140 psi)
Air consumption ⁽¹⁾	180 NL/min (6.4 cfm)
Maximum fluid outlet pressure	30 bar (420 psi)
Air motor diameter	51 mm (2")
Air motor effective diameter	35 mm (1.4")
Air motor stroke	75 mm (3")
Delivery at 200 cpm	10 l/min (2.7 US gpm)
Maximum free flow delivery ⁽²⁾	35 l/min (9.3 US gpm)
Air inlet	1/4" BSP (F)
Fluid inlet (short pump only)	3/4" BSP (F)
Fluid outlet	1/2" BSP (F)
Wetted and seal materials	Aluminium / Steel / NBR / PTFE
Noise level ⁽³⁾	80 dB

(1) Air consumption with 6 bar air inlet pressure and 200 cycles per minute.

(2) Maximum free delivery at 7 bar.

(3) Maximum noise level measured at 1 m from the pump, 7 bar air pressure and free delivery.

DIMENSIONS (mm)			
MODEL	353 120	358 120	354 120
A (mm)	495	995	1.200
B (mm)	295	295	295
C (mm)	34	34	34
D (mm)	200	700	905

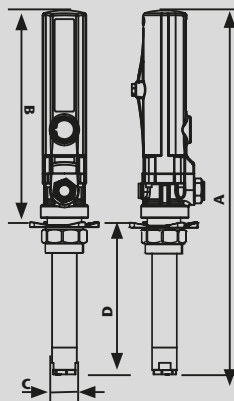

SAE 30 - 20 °C (68 °F) CAPACITY

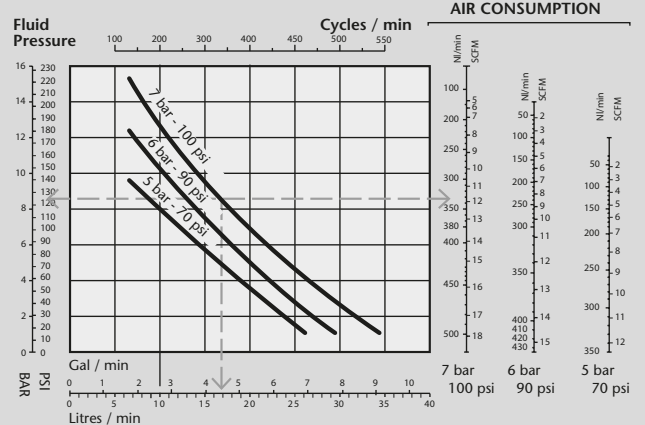

Lubricant dispensing and transfer require more than a bare pump. SAMOA offers a range of pump packages and installation kits that include all the accessories needed to efficiently dispense or transfer lubricants. Packages and kits can be used with 205 litre oil drums, 1.000 l IBCs and tanks. They provide an easy solution to common applications.



PUMPMASTER 2 - 3:1 OIL PUMP PACKAGES

PART No.	DESCRIPTION	APPLICATION	PUMP	HOSE	DELIVERY GUN	APPROX. DELIVERY
454 110	3:1 transfer metered package	205 l drums	354 120	3 m x 1/2" (362 103)	Hose end meter 365 535	12 l/min ⁽¹⁾
454 111	3:1 transfer package	205 l drums	354 120	3 m x 1/2" (362 103)	Oil control gun 363 115	15 l/min ⁽¹⁾
454 100	Transfer pump with spigot valve	205 l drums	352 220 ⁽³⁾	-	Oil spigot valve 361 100 and tray 736 462	23 l/min ⁽¹⁾
454 150	3:1 transfer pump + IBC side bracket ⁽²⁾	1.000 l IBC	353 120	6 m x 1/2" (362 106)	Hose end meter 365 535	12 l/min ⁽¹⁾

(1) Delivery with SAE 30 oil at 7 bar inlet pressure and 20 °C room temperature.
 (2) Includes suction hose 745 304 with elbow and connection accessories.
 (3) 2:1 pressure ratio pump.

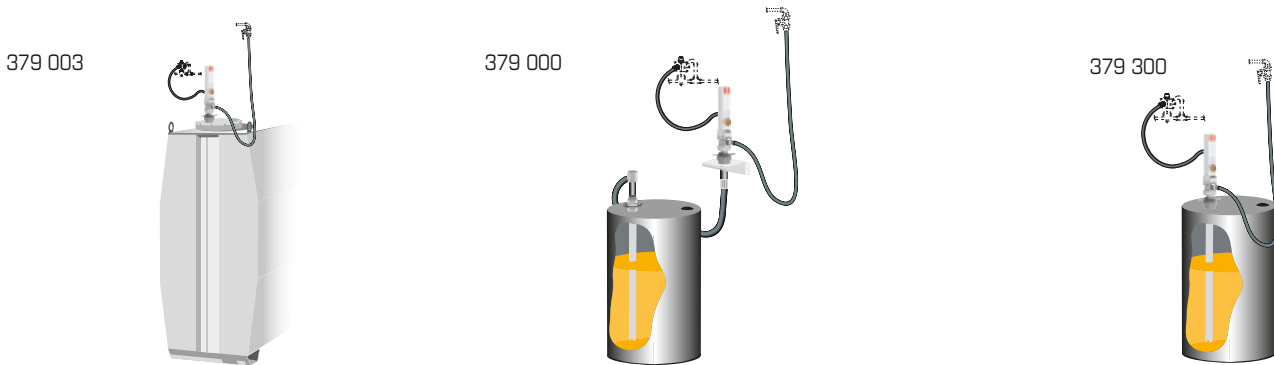

PUMPMASTER 2 - 3:1 OIL PUMP KITS

	PUMPMASTER 2 TANK MOUNTED PUMP KIT	PUMPMASTER 2 WALL MOUNTED PUMP KIT	PUMPMASTER 2 DRUM BUNG MOUNTED PUMP KIT
PART No.	379 003	379 000	379 300
APPLICATION	Tanks	205 l drums	205 l drums
PUMP	353 120	353 120	354 120
SUCTION KIT	1.400 mm suction tube 368 104	367 102	-
HOSE CONNECTION KIT	362 910	362 910	362 910

PUMP PACKAGE AND KIT ACCESSORIES

- 239 000:** 1/4" BSP (MM) connection adaptor.
- 240 200:** Air pressure regulator, 0-12 bar, 1/4" BSP (FF).
- 240 500:** Air filter and pressure regulator, 0-12 bar, 1/4" BSP (FF).
- 609 007:** Pressure relief valve, 1/4" BSP (M) - 60 bar approx. opening pressure. When mounted to the pump body, prevents damage in the system caused by over pressure produced by thermal expansion (1 °C increase in temperature can cause up to 10 bar increase in the system pressure).
- 950 300:** 1/2" BSP (FF) ball valve.

PUMPMASTER 2 - 3:1 RATIO OIL PUMPS

454 605



454 659



454 694



PUMPMASTER 2 - 3:1 OIL PUMP PACKAGES

PART No.	APPLICATION	PUMP	HOSE END METER	HOSE REEL	PUMP CONNECTION KIT	SUCTION KIT	PUMP BRACKET	DRIP POCKET
454 605	205 l drum, drum mounted	354 120	365 535	506 202	362 910	-	-	-
454 600	205 l drum, drum mounted	354 120	365 535	501 200	362 910	-	-	-
454 651	205 l drum, wall mounted	353 120	365 535	506 202	362 910	367 000	360 102	360 127
454 653	205 l drum, wall mounted	353 120	365 535	501 200	362 910	367 000	360 102	360 127
454 659	205 l drum, wall mounted	353 120	365 535	507 202	362 910	367 000	360 102	360 127
454 694	1.000 l IBC, IBC top mounted	353120	365 535	506 202	-	745 300 + 745 301 + 945 572	360 102 + 360 106	-
454 695	1.000 l IBC, IBC top mounted	353 120	365 535	501 200	-	745 300 + 745 301 + 945 572	360 102 + 360 106	-
454 699	1.000 l IBC, IBC side mounted	353 120	365 535	506 202	-	745 301 + 745 302 + 945 572	360 102 + 360 107	-
454 697	1.000 l IBC, IBC side mounted	353 120	365 535	501 200	-	745 301 + 745 302 + 945 572	360 102 + 360 107	-

376 300 - 378 120

MOBILE UNITS WITH PUMPMASTER 3:1 OIL PUMP



PART No.	APPLICATION	PUMP	HOSE END METER	DELIVERY HOSE	TROLLEY	OTHER ACCESSORIES
370 400	50 l drum	358 120	365 535	3 m x 1/2" 362 103	431 000	Drum cover 418 010
328 010	Self contained, 70 l	358 120	365 535	3 m x 1/2" 362 103	373 310	Self contained 70 l tank
376 300	205 l drum	354 120	365 535	3 m x 1/2" 362 103	432 000	-
376 610	205 l drum	353 120	365 535	3 m x 1/2" 362 103	432 814	Suction hose 367 011
378 120	205 l drum	353 120	365 535	10 m hose reel 506 202	432 814	Suction hose 367 011



PUMPMASTER 2 ACCESSORIES, OTHER MOBILE OIL DISPENSERS

PUMPMASTER 2 ACCESSORIES

360 102

360 102 Wall bracket
360 120 Floor bracket

360 120



360 001

BUNG ADAPTORS 2" (M) CONNECTION FOR DRUM AND TANKS BUNG OPENINGS
360 000 Bung adaptor for PM2 3:1 pumps
 Pump tube outside diameter: 34 mm.

360 001 Bung adaptor for PM2 1:1 pumps
 Pump tube outside diameter: 52 mm.

367 000

SUCTION ASSEMBLIES AND SUCTION HOSES
 Suction assemblies for wall mounted stub pumps. Assemblies include Ø 42 suction tube with foot valve, height adjustable 2" bung adaptor and 2 m x 3/4" rubber connection hose.

367 000 Suction assembly for 1.000 l IBC and 205 l drums
 1.060 mm suction tube.

367 003 Suction assembly for tanks
 1.600 mm suction tube.

367 011 spring reinforced transparent suction hose
 For 205 l drums and 1.000 l IBC. 3 m x 3/4".

367 012 spring reinforced transparent suction hose with foot valve
 For 205 l drums and 1.000 l IBC. 3 m x 3/4", includes foot valve.

367 102 Pump suction kit
 Includes suction assemble 367 000 and pump bracket 360 102.

367 011

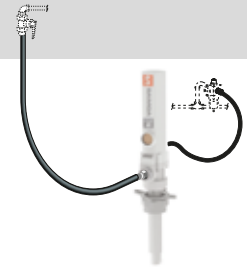

369 910

HOSE CONNECTION KIT
362 910 PM2 pump connection kit
 1 m x 1/4" air hose 246 010, one 1/2" BSP (M) x 1/4" BSP (M) connection adapter 945 516, 1 m x 1/2" oil hose with 1/2" BSP (MM) fittings, one automatic quick air coupling 1/4" BSP (F) 253114 and one quick air connector 1/4" BSP (M).

609 007

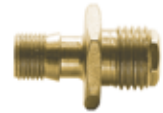
PRESSURE RELIEF VALVE
 SAMOA pumps include a 1/4" plug that can be removed and replaced with a pressure relief valve.

609 007 Pressure relief valve
 Opens at approx. 60 bar. Possibility to connect either a 1/4" hose with a clamp or a hose with 1/8" BSP (F) fitting as oil return live.

OTHER MOBILE OIL DISPENSERS

PRESSURIZED LUBRICANT DISPENSERS 25 LITRES

Mobile unit for dispense viscous lubricants. Includes a 25 l container that must be pressurized using a tire inflator at maximum 7 bar (100 psi). Includes safety valve and 1,5 m delivery hose with oil gun.

324 000 Pressurized lubricant dispenser, 25 litres.
324 010 Pressurized lubricant dispenser, 25 litres with meter.

SELF CONTAINED AIR OPERATED LUBRICANT DISPENSER 25 LITRES

Mobile unit to dispense viscous lubricants. Includes a 25 l capacity tank, a 2:1 pneumatic pump, oil meter at pump outlet, 1,5 m delivery hose and oil gun with non-drip tip.

327 020 Self contained air operated lubricant dispenser with meter, 25 litres.

SELF CONTAINED HAND OPERATED LUBRICANT DISPENSERS 25 LITRES

Mobile unit to dispense viscous lubricants. Includes a 25 l capacity tank, a hand pump and a 1,5 m delivery hose with angled spout.

325 000 Self contained hand operated lubricant dispenser, 25 litres.
325 010 Self contained hand operated lubricant dispenser with meter, 25 litres. Includes in line meter at the pump outlet.

SELF CONTAINED HAND OPERATED LUBRICANT DISPENSERS 70 LITRES

Mobile unit to dispense viscous lubricants. Includes a 70 l capacity tank, a hand pump and a 1,5 m delivery hose with angled spout.

326 000 Self contained hand operated lubricant dispenser, 65 litres.
326 010 Self contained hand operated lubricant dispenser with meter, 65 l
 Includes in line meter at the pump outlet.

PUMPMASTER 4 - 3:1 RATIO OIL PUMPS

STANDARD DUTY MEDIUM PRESSURE PUMPS

Double acting air operated medium pressure high volume pumps for dispensing lubricants in medium size installations. Pumps include height adjustable 2" BSP (M) bung adaptor for drum and tank bung mounting. Built in port for optional pressure relief valve (PN 609 007).



FLUIDS HANDLED

- Synthetic and mineral based lubricants.
- Gear oil.
- Hydraulic oil.
- Transmission fluid.

MARKETS SERVED

- Vehicle maintenance centres and auto dealers.
- Fleet service.
- Fast lube centres.
- Lube trucks.
- Mining and construction.
- In-plant.

MODELS				
PART No.	APPLICATION	PUMP TUBE HEIGHT	TOTAL HEIGHT	WEIGHT
340 120	Universal stub pump	200 mm	585 mm	5,7 kg
341 120	205 l (55 gal) drum bung mounted	910 mm	1.295 mm	7,7 kg

TECHNICAL DATA	
Pump pressure ratio	3:1
Air pressure operating range	1,5 - 10 bar (20 to 140 psi)
Air consumption ⁽¹⁾	285 NL/min (10 cfm)
Maximum fluid outlet pressure	30 bar (420 psi)
Air motor diameter	88 mm (3.5")
Air motor effective diameter	60 mm (2.4")
Air motor stroke	100 mm (4")
Delivery at 85 cpm	10 l/min (2.7 US gpm)
Maximum free flow delivery ⁽²⁾	42 l/min (11.1 US gpm)
Air inlet	3/8" BSP (F)
Fluid inlet (short pump only)	1" BSP (F)
Fluid outlet	3/4" BSP (F)
Wetted and seal materials	Aluminium / Steel / Polyurethane / NBR / PTFE
Noise level ⁽³⁾	93 dB

(1) Air consumption with 6 bar air inlet pressure and 10 l/min delivery.

(2) Maximum free delivery at 7 bar.

(3) Maximum noise level measured at 1 m from the pump, 7 bar air pressure and free delivery.

SAE 30 - 20 °C (68 °F) CAPACITY

Fluid Pressure Cycles / min

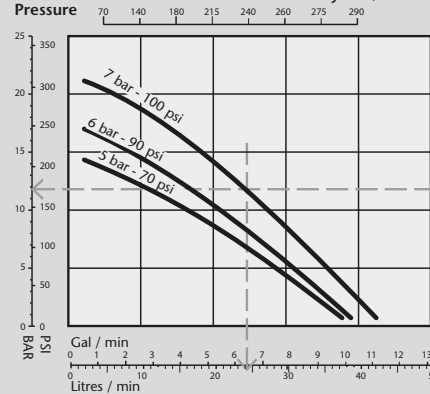

AIR CONSUMPTION

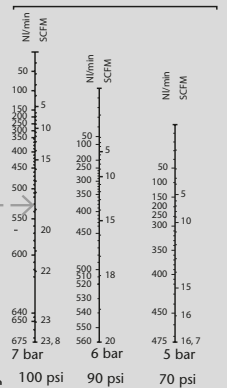

DIMENSIONS (mm)		
MODEL	340 120	341 120
A (mm)	585	1.295
B (mm)	385	385
C (mm)	52	52
D (mm)	200	910

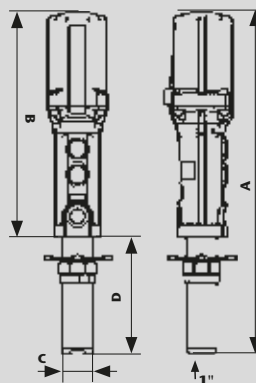

347 120

PUMPMASTER 4 - 5:1 RATIO OIL PUMPS

STANDARD DUTY MEDIUM PRESSURE PUMPS

Double action air operated medium pressure pumps for dispensing lubricants in medium to large size installations, that include multiple outlets with simultaneous operation. Pumps include height adjustable 2" BSP (M) bung adaptor for drum and tank bung mounting. Built in port for optional pressure relief valve (PN 609 007).



FLUIDS HANDLED

- Synthetic and mineral based lubricants.
- Gear oil.
- Hydraulic oil.
- Transmission fluid.

MARKETS SERVED

- Auto and truck dealers.
- Fleet service facilities.
- Mining and construction.
- Lube trucks.
- Marine.
- Railroad and mass transit.
- In-plant.

MODELS				
PART No.	APPLICATION	PUMP TUBE HEIGHT	TOTAL HEIGHT	WEIGHT
347 120	Universal stub pump	278 mm	663 mm	5,6 kg
348 120	205 l (55 gal) drum bung mounted	915 mm	1.300 mm	7,4 kg

TECHNICAL DATA	
Pump pressure ratio	5:1
Air pressure operating range	1,5 - 10 bar (20 to 140 psi)
Air consumption ⁽¹⁾	400 NL/min (14 cfm)
Maximum fluid outlet pressure	50 bar (700 psi)
Air motor diameter	88 mm (3.5")
Air motor effective diameter	60 mm (2.4")
Air motor stroke	100 mm (4")
Delivery at 125 cpm	10 l/min (2.7 US gpm)
Maximum free flow delivery ⁽²⁾	25 l/min (6.6 US gpm)
Air inlet	3/8" NPSM
Fluid inlet (short pump only)	1" BSP (F)
Fluid outlet	3/4" NPSM
Wetted and seal materials	Aluminium / Steel / Polyurethane / NBR / PTFE
Noise level ⁽³⁾	95 dB

(1) Air consumption with 6 bar air inlet pressure and 10 l/min delivery.

(2) Maximum free delivery at 7 bar.

(3) Maximum noise level measured at 1 m from the pump, 7 bar air pressure and free delivery.

DIMENSIONS (mm)		
MODEL	347 120	348 120
A (mm)	663	1.300
B (mm)	385	385
C (mm)	42	42
D (mm)	278	915

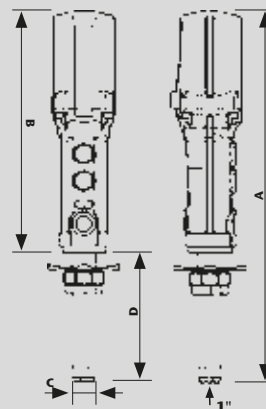

SAE 30 - 20 °C (68 °F) CAPACITY

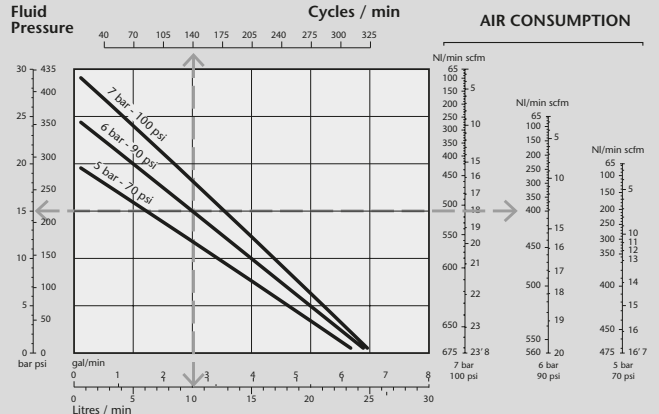

PUMPMASTER 4 - 8:1 RATIO OIL PUMPS

349 120

STANDARD DUTY HIGH PRESSURE PUMP



Double acting air operated high pressure pumps for dispensing lubricants in applications requiring higher pressure and moderate flow rates, such as medium to large size installations including multiple outlets with no simultaneous use. Pumps include height adjustable 2" BSP (M) bung adaptor for drum or tank bung mounting. Built in port for optional pressure relief valve (PN 609 007).

FLUIDS HANDLED

- Synthetic and mineral based lubricants.
- Hydraulic oil.
- Gear oil.
- Transmission fluid.
- Corrosion protection fluids.

MARKETS SERVED

- Vehicle maintenance centres.
- Fleet service facilities.
- Marine.
- Mining and construction.
- Lube trucks.

MODELS				
PART No.	APPLICATION	PUMP TUBE HEIGHT	TOTAL HEIGHT	WEIGHT
349 120	Universal stub pump	242 mm	627 mm	5,7 kg
349 121	205 l (55 gal) drum bung mounted	932 mm	1.317 mm	7,4 kg

TECHNICAL DATA	
Pump pressure ratio	8:1
Air pressure operating range	3 -10 bar (40 to 140 psi)
Air consumption ⁽¹⁾	450 NL/min (16 cfm)
Maximum fluid outlet pressure	80 bar (1,120 psi)
Air motor diameter	88 mm (3.5")
Air motor effective diameter	60 mm (2.4")
Air motor stroke	100 mm (4")
Delivery at 200 cpm	10 l/min (2.7 US gpm)
Maximum free flow delivery ⁽²⁾	22 l/min (5.8 US gpm)
Air inlet	3/8" BSP (F)
Fluid inlet (short pump only)	3/4" BSP (F)
Fluid outlet	3/4" BSP (F)
Wetted and seal materials	Aluminium / Steel / NBR / PTFE
Noise level ⁽³⁾	95 dB

(1) Air consumption with 6 bar air inlet pressure and 10 l/min delivery.

(2) Maximum free delivery at 7 bar.

(3) Maximum noise level measured at 1 m from the pump, 7 bar air pressure and free delivery.

DIMENSIONS (mm)		
MODEL	349 120	349 121
A (mm)	627	1.317
B (mm)	385	385
C (mm)	34	34
D (mm)	242	932

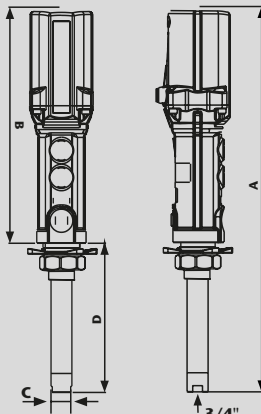

SAE 30 - 20 °C (68 °F) CAPACITY

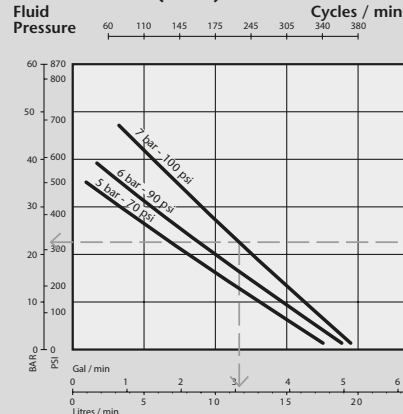

AIR CONSUMPTION

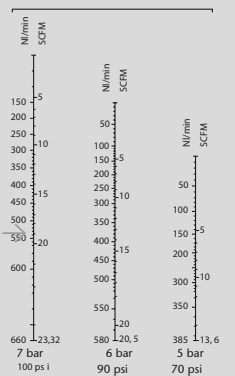

Installing an oil pump in a distribution system requires more than a bare pump. SAMOA offers a range of installation kits that include all the accessories needed to efficiently dispense or transfer lubricants. Kits can be used with 205 litre oil drums, 1.000 litre IBCs and tanks and they provide an easy solution to common applications.

379 503

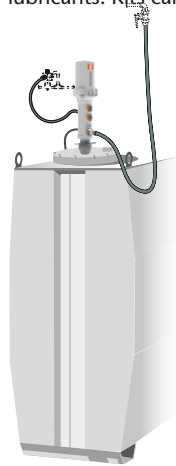

379 500



379 504



PUMP RATIO	TANK MOUNTED PUMP KIT		WALL MOUNTED PUMP KIT		205 L DRUM MOUNTED PUMP KIT	
	PM4 - 3:1	PM4 - 5:1	PM4 - 3:1	PM4 - 5:1	PM4 - 3:1	PM4 - 5:1
KIT PART NUMBER	379 403	379 503	379 400	379 500	379 404	379 504
PUMP	340 120	347 120	340 120	347 120	341 120	348 120
SUCTION KIT	368 105 1.400 mm suction tube	368 105 1.400 mm suction tube	367 105	367 105	-	-
HOSE CONNECTION KIT	362 911	362 911	362 911	362 911	362 911	362 911

PUMP KIT ACCESSORIES

239 004: 1/2" BSP (MM) connection adaptor

241 201: Air pressure regulator, 0-12 bar, 3/8" BSP (F) - 1/2" BSP (F)

241 501: Air filter and pressure regulator, 0-12 bar, 3/8" BSP (F) - 1/2" BSP (F)

609 007: Pressure relief valve, 1/4" BSP (M) - 60 bar approx. opening pressure. When mounted to the pump body, prevents damage in the system caused by over pressure produced by thermal expansion (1 °C increase in temperature can cause up to 10 bar increase in the system pressure).

950 303: 3/4" BSP (FF) ball valve.

PUMPMASTER 4 PUMP ACCESSORIES

360 102



360 102 Wall bracket
360 120 Floor bracket

360 120



367 000



SUCTION ASSEMBLIES AND SUCTION HOSES

Suction assemblies for wall mounted stub pumps. Assemblies include Ø 42 suction tube with foot valve, height adjustable 2" bung adaptor and 2 m x 3/4" rubber connection hose.

367 000 Suction assembly for 1.000 litre IBC and 205 litre drums

1.060 mm suction tube.

367 003 Suction assembly for tanks

1.600 mm suction tube.

362 400 1 m x 1" connection hose. For

connecting a PM4 pump to tank 1" BSP (M) connection on both sides, with a 90° connection on one side.

945 670 1" BSP (M) x 3/4" BSP (M) connection adaptor

Required for connecting the suction assemblies to a PM4 pump.

362 911



HOSE CONNECTION KIT

362 911 PumpMaster 4 pump connection kit

Includes 1 m x 3/8" air hose 247 710 with 1/2" and 3/8" BSP (M) fittings, 1,5 m x 3/4" oil hose with 3/4" BSP (MM) fittings 362301, one automatic quick air coupling 3/8" BSP (F) 253 138 and one quick air connector 3/8" BSP (M) 259 038.

PRESSURE RELIEF VALVE

SAMOA pumps include a 1/4" plug that can be removed and replaced with a pressure relief valve.

609 007 Pressure relief valve

opens at approx. 60 bar. Possibility to connect either a 1/4" hose with a clamp or a hose with 1/8" BSP (F) fitting as oil return live.

609 007

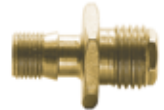

360 002



BUNG ADAPTOR 2" (M) CONNECTION FOR DRUM AND TANKS BUNG OPENINGS

360 001 Bung adaptor for PM4 - 3:1 pump

Pump tube outside diameter: 52 mm.

360 002 Bung adaptor for PM4 - 5:1 pumps

Pump tube outside diameter: 42 mm.

INTENSIVE DUTY PISTON PUMPS: THE HEART OF A LUBRICATION SYSTEM

SAMOA Intensive Duty pumps are designed to deliver through long distribution lines even with multiple outlets with simultaneous operation all kind of synthetic and petroleum based lubricants at continuous-duty and high flow rates under extreme and intensive working conditions.

These double acting, high efficiency, air powered, positive displacement piston, pumps provide the necessary confidence to offer a solution for fast moving large volumes of oil in very large distance applications.

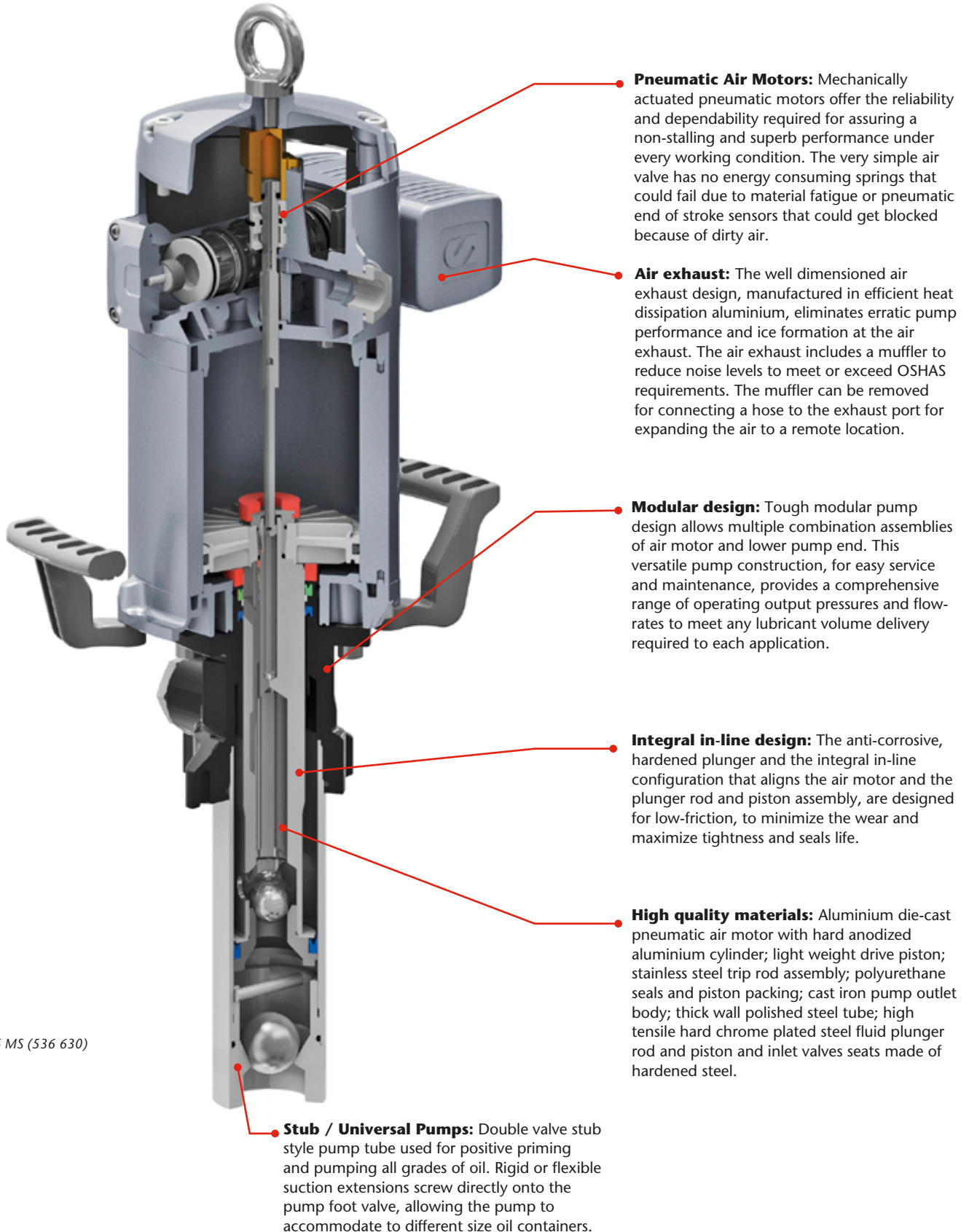

PM 45 - 06 MS (536 630)

PUMPMASTER 45 - 3:1 RATIO OIL PUMP

536 330

INTENSIVE DUTY VOLUME TRANSFER PUMP

Double acting air operated medium pressure and high delivery pump for large volume transfer applications. Built in port for optional pressure relief valve (PN 609 007). Flange mounted pump.



FLUIDS HANDLED

- Synthetic and mineral based lubricants.
- Hydraulic oil.
- Gear oil.
- Transmission fluid.

MARKETS SERVED

- Construction equipment.
- Mining equipment.
- Large fleets.
- Railroad and mass transit maintenance.
- Marine.
- In plant oil distribution and transfer.

MODELS				
PART No.	APPLICATION	PUMP TUBE HEIGHT	TOTAL HEIGHT	WEIGHT
536 330	Universal stub pump	200 mm	702 mm	17 kg

TECHNICAL DATA	
Pump pressure ratio	3:1
Air pressure operating range	1,5 to 12 bar (20 to 170 psi)
Air consumption ⁽¹⁾	800 NI/min (28 cfm)
Maximum fluid outlet pressure	36 bar (510 psi)
Air motor effective diameter	115 mm (4 1/2")
Air motor stroke	100 mm (4")
Delivery at 80 cpm	45 l/min (11.88 gal/min)
Maximum free flow delivery	120 l/min (31.70 gal/min)
Air inlet	1/2" BSP (F)
Fluid inlet	1 1/2" BSP (F)
Fluid outlet	3/4" BSP (F)
Wetted and seal materials	Cast iron / Nickel / Aluminium / Steel / Polyurethane / NBR
Noise level ⁽²⁾	80 dB

(1) Maximum air consumption with 5 bar air inlet pressure and 80 cpm.

(2) Maximum noise level measured at 1 m from the pump, 7 bar air pressure and free delivery.

DIMENSIONS (mm)	
MODEL	536 330
A (mm)	702
B (mm)	502
C (mm)	90
D (mm)	200

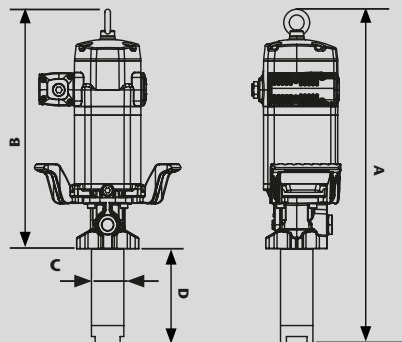
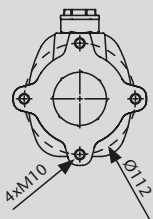

SAE 10, 21 °C (70 °F) CAPACITY

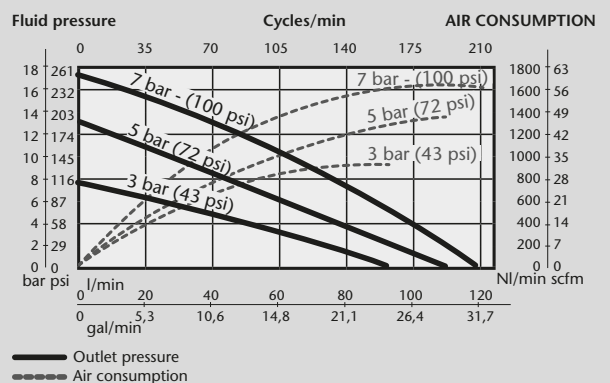

PUMPMASTER 45 - 6:1 RATIO OIL PUMP

536 630

INTENSIVE DUTY HIGH FLOW PUMP

Double acting air operated medium pressure for large systems with simultaneous operation outlets that require a high delivery pump. Built in port for optional pressure relief valve (PN 609 007). Flange mounted pump.



PRODUCTS HANDLED

- Synthetic and mineral based lubricants.
- Hydraulic oil.
- Gear oil.
- Transmission fluid.

MARKETS

- Large auto and truck dealers.
- Construction equipment maintenance.
- Mining equipment maintenance.
- Large fleets.
- Railroad and mass transit maintenance.
- Marine.
- In plant oil distribution.

MODELS				
PART No.	APPLICATION	PUMP TUBE HEIGHT	TOTAL HEIGHT	WEIGHT
536 630	Universal stub pump	200 mm	702 mm	17 kg

TECHNICAL DATA	
Pump pressure ratio	6:1
Air pressure operating range	1,5 to 12 bar (20 to 170 psi)
Air consumption ⁽¹⁾	830 NI/min (29 cfm)
Maximum fluid outlet pressure	72 bar (1,020 psi)
Air motor effective diameter	115 mm (4 1/2")
Air motor stroke	100 mm (4")
Delivery at 80 cpm	25 l/min (6.60 gal/min)
Maximum free flow delivery	95 l/min (25.09 gal/min)
Air inlet	1/2" BSP (F)
Fluid inlet	1 1/2" BSP (F)
Fluid outlet	3/4" BSP (F)
Wetted and seal materials	Cast iron / Hard chromed steel / Steel / Polyurethane / NBR
Noise level ⁽²⁾	80 dB

(1) Maximum air consumption with 5 bar air inlet pressure and 80 cpm.

(2) Maximum noise level measured at 1 m from the pump, 7 bar air pressure and free delivery.

DIMENSIONS (mm)	
MODEL	536 630
A (mm)	702
B (mm)	502
C (mm)	70
D (mm)	200

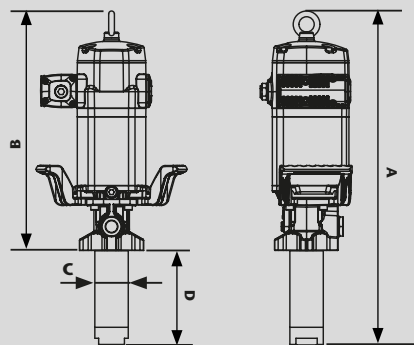

SAE 10, 21 °C (70 °F) CAPACITY

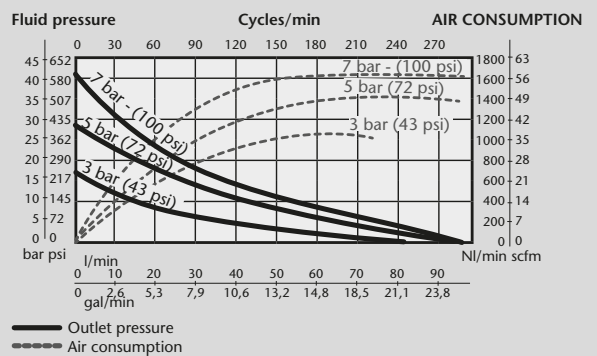

PUMPMASTER 45 - 10:1 RATIO OIL PUMPS

536 010

INTENSIVE DUTY PRESSURE FLOW PUMPS

Double acting air operated moderate pressure pump for very large oil systems or when a low air pressure or cold temperatures would limit pump performance. Built in port for optional pressure relief valve (PN 609 007). Flange mounted pumps. Pump 536 010 can also use bung adaptor (PN 360 006) for bung mounting.



PRODUCTS HANDLED

- Synthetic and mineral based lubricants.
- Hydraulic oil.
- Gear oil.
- Transmission fluid.

MARKETS

- Large auto and truck dealers.
- Construction equipment maintenance.
- Mining equipment maintenance.
- Railroad and mass transit maintenance.
- Large fleets.
- Lube trucks.
- Marine.
- In plant oil distribution.

MODELS				
PART No.	APPLICATION	PUMP TUBE HEIGHT	TOTAL HEIGHT	WEIGHT
536 030	Universal stub pump	200 mm	702 mm	16,5 kg
536 010	205 l drum bung mounted	855 mm	1.357 mm	17 kg

TECHNICAL DATA	
Pump pressure ratio	10:1
Air pressure operating range	1,5 to 12 bar (20 to 170 psi)
Air consumption ⁽¹⁾	850 NI/min (30 cfm)
Maximum fluid outlet pressure	120 bar (1,700 psi)
Air motor effective diameter	115 mm (4 1/2")
Air motor stroke	100 mm (4")
Delivery at 80 cpm	15 l/min (4 gal/min)
Maximum free flow delivery	65 l/min (17.17 gal/min)
Air inlet	1/2" BSP (F)
Fluid inlet	1 1/2" BSP (F)
Fluid outlet	3/4" BSP (F)
Wetted and seal materials	Cast iron / Hard chromed steel / Steel / Polyurethane / NBR
Noise level ⁽²⁾	80 dB

(1) Maximum air consumption with 5 bar air inlet pressure and 80 cpm.

(2) Maximum noise level measured at 1 m from the pump, 7 bar air pressure and free delivery.

DIMENSIONS (mm)		
MODEL	536 030	536 010
A (mm)	702	1.357
B (mm)	502	502
C (mm)	54	54
D (mm)	200	855

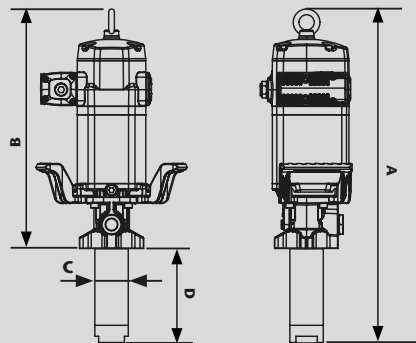

SAE 10, 21 °C (70 °F) CAPACITY

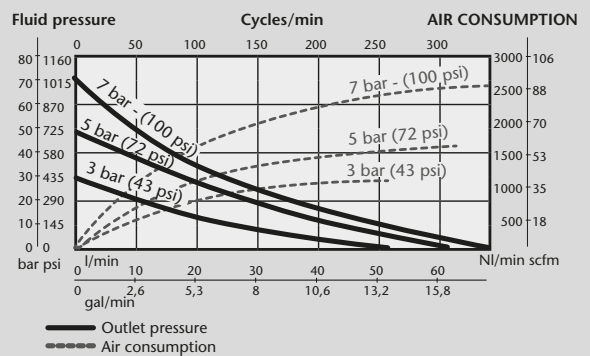

PUMPMASTER 60 - 6:1 RATIO OIL PUMP

537 630

INTENSIVE DUTY HIGH DELIVERY PUMP

Double acting air operated medium pressure and high delivery pump, for large installations with simultaneous operation outlets and applications that require large, constant delivery rates. Built in port for optional pressure relief valve (PN 609 007). Flange mounted pump.



PRODUCTS HANDLED

- Synthetic and mineral based lubricants.
- Hydraulic oil.
- Gear oil.
- Transmission fluid.

MARKETS

- Very large auto and truck dealers.
- Construction equipment maintenance.
- Mining equipment maintenance.
- Large fleets.
- Railroad and mass transit maintenance.
- Marine.
- In plant oil distribution.

MODELS

PART No.	APPLICATION	PUMP TUBE HEIGHT	TOTAL HEIGHT	WEIGHT
537 630	Universal stub pump	200 mm	716 mm	19 kg

TECHNICAL DATA

Pump pressure ratio	6:1
Air pressure operating range	1,5 to 12 bar (20 to 170 psi)
Air consumption ⁽¹⁾	1.100 NI (39 cfm)
Maximum fluid outlet pressure	72 bar (1,020 psi)
Air motor effective diameter	150 mm (6")
Air motor stroke	100 mm (4")
Delivery at 60 cpm	35 l/min (9.25 gal/min)
Maximum free flow delivery	100 l/min (26.42 gal/min)
Air inlet	1/2" BSP (F)
Fluid inlet	1 1/2" BSP (F)
Fluid outlet	3/4" BSP (F)
Wetted and seal materials	Cast iron / Aluminium / Nickel / Steel / Polyurethane / NBR
Noise level ⁽²⁾	80 dB

(1) Maximum air consumption with 5 bar air inlet pressure and 60 cpm.

(2) Maximum noise level measured at 1 m from the pump, 7 bar air pressure and free delivery.

DIMENSIONS (mm)

MODEL	537 630
A (mm)	716
B (mm)	516
C (mm)	90
D (mm)	200

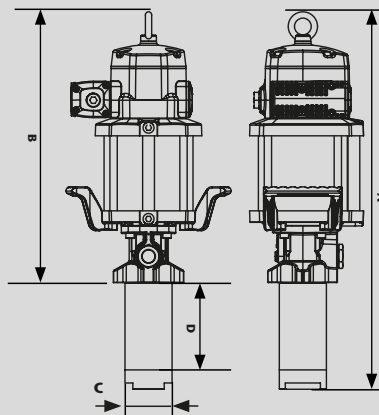
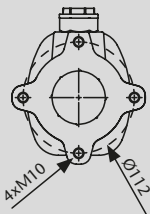

SAE 10, 21 °C (70 °F) CAPACITY

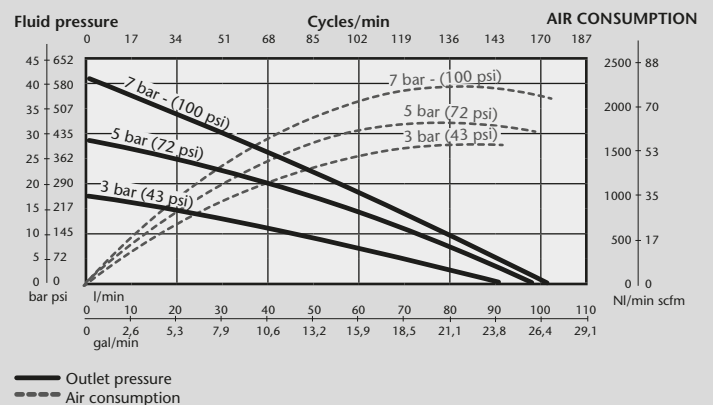

PUMPMASTER 60 - 12:1 RATIO OIL PUMP

537 130

INTENSIVE DUTY HIGH PERFORMANCE PUMP

Double acting air operated moderate pressure and high delivery for very large installation with simultaneous operation outlets or when low air pressure would limit pump performances. Built in port for optional pressure relief valve (PN 609 007). Flange mounted pump.



PRODUCTS HANDLED

- Synthetic and mineral based lubricants.
- Hydraulic oil.
- Gear oil.
- Transmission fluid.

MARKETS

- Very large auto and truck dealers.
- Construction equipment maintenance.
- Mining equipment maintenance.
- Large fleets.
- Railroad and mass transit maintenance.
- Marine.
- In plant oil distribution.

MODELS				
PART No.	APPLICATION	PUMP TUBE HEIGHT	TOTAL HEIGHT	WEIGHT
537 130	Universal stub pump	200 mm	716 mm	19 kg

TECHNICAL DATA	
Pump pressure ratio	12:1
Air pressure operating range	1,5 to 12 bar (20 to 170 psi)
Air consumption ⁽¹⁾	1.150 NI (41 cfm)
Maximum fluid outlet pressure	144 bar (2,040 psi)
Air motor effective diameter	150 mm (6")
Air motor stroke	100 mm (4")
Delivery at 60 cpm	20 l/min (5.30 gal/min)
Maximum free flow delivery	65 l/min (17 gal/min)
Air inlet	1/2" BSP (F)
Fluid inlet	1 1/2" BSP (F)
Fluid outlet	3/4" BSP (F)
Wetted and seal materials	Cast iron / Hard chromed steel / Steel / Polyurethane / NBR
Noise level ⁽²⁾	80 dB

(1) Maximum air consumption with 5 bar air inlet pressure and 60 cpm.
 (2) Maximum noise level measured at 1 m from the pump, 7 bar air pressure and free delivery.

DIMENSIONS (mm)	
MODEL	537 130
A (mm)	716
B (mm)	516
C (mm)	70
D (mm)	200

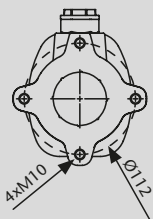
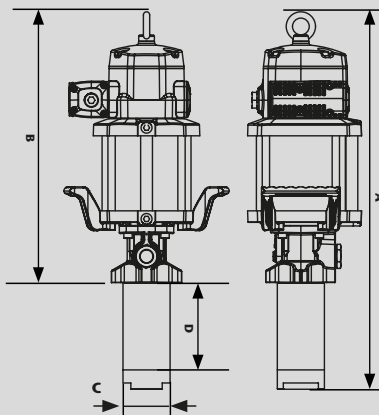

SAE 10, 21 °C (70 °F) CAPACITY

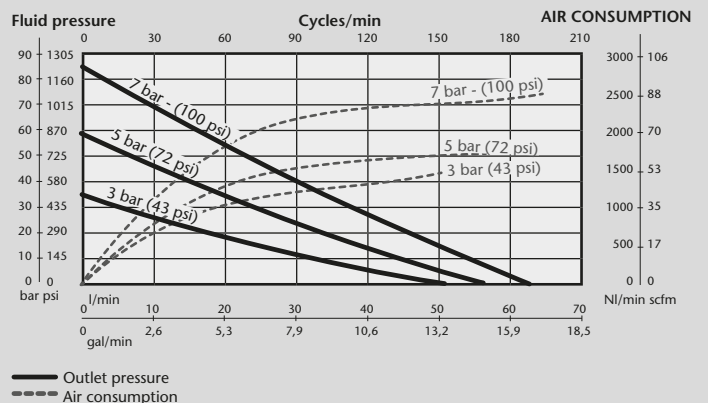



PUMPMASTER 45 AND 60 ACCESSORIES

539 009



HOSE CONNECTION KIT

539 009 Hose Connection kit for PM45 and PM60 oil pumps

Includes 1 m x 1/2" air hose (PN 248 018) with swivel elbow (PN 239 352), quick air coupler (PN 251 412), air nipple (PN 255 312), and 2 m x 3/4" oil hose (PN 362 302) with swivel elbow (PN 945 738).

360 132 - 360 121

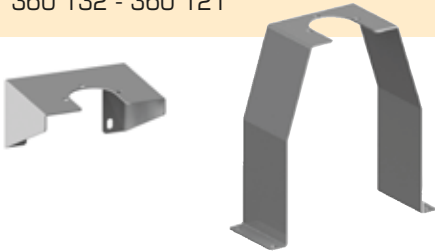

PUMP BRACKETS

360 132 Wall bracket. For PM45 and PM60 universal stub pumps.
360 121 Floor bracket. For PM45 and PM60 universal stub pumps.

360 006



BUNG ADAPTOR

For use with PM45 10:1 pressure ratio pumps only

PM45 10:1 pumps are the only pumps with a 2" pump tube and therefore the only pumps that fit through 2" bung openings on drums and tanks. All other PM45 and PM60 pumps must be wall or floor mounted using an adequate bracket and suction accessories.

360 006 Bung adaptor

For PM45 10:1 pumps only.

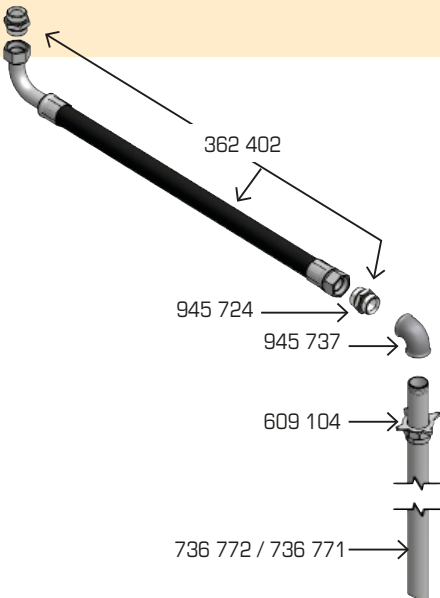

SUCTION ACCESSORIES

367 016 Suction assembly for 205 l drums and lbs. For use with PM45 10:1 wall mounted universal stub pumps only.

It includes a 42 mm x 2 m suction tube with foot valve and 2 m x 3/4" hose.

362 402 Suction hose 1.800 mm x 1-1/2" rubber connection hose.

1-1/2" BSP (M) connection elbow on one side and 1-1/2" (M) straight connection on the other.

945 724 Connection adaptor, 1-1/2" BSP (MM).

945 737 Elbow, 1-1/2" BSP (FF).

609 104 Bung adaptor

Adaptor for fixing tube 736 771 to a 2" bung opening.

736 772 Suction tube

1.000 x 1-1/2", 1-1/2" BSP (MF) connection threads.

736 771 Suction tube

1.250 x 1-1/2", 1-1/2" BSP (MF) connection threads.

609 007



PRESSURE RELEASE VALVES

Prevent damage caused by overpressure due to oil thermal expansion.

609 007 Pressure release valve. Opening pressure approximate 60 bar.

609 008 Pressure release valve. Opening pressure approximate 100 bar.

OIL PUMP ACCESSORIES

PUMP BRACKETS



360 102



360 120



360 108

PM2 AND PM4 PUMP BRACKETS

360 102 Wall bracket

360 120 Floor bracket

360 106 Bracket for fixing a pump and a hose reel on top of a 1.000 l IBC

Requires pump bracket 360 102 (not included).

360 107 Bracket for fixing a pump and a hose reel laterally on a 1.000 l IBC

Requires pump bracket 360 102 (not included).

360 108 Bracket for fixing a pump laterally on a 1.000 l IBC

Requires pump bracket 360 102 (not included).

PM45 AND PM60 PUMP BRACKETS

360 132 Wall bracket

360 121 Floor bracket

AIR ACCESSORIES



240 200



241 501



241 202

	1/4" CONNECTION THREADS 1/4" BSP (FF)	1/2" CONNECTION THREADS 1/2" BSP (FF) with one 1/2" BSP (M) - 3/8" BSP (F) adaptor	3/4" CONNECTION THREADS 3/4" BSP (FF)
AIR PRESSURE REGULATOR 0 - 12 BAR	240 200	241 201	242 202
COMBINED AIR FILTER AND PRESSURE REGULATOR	240 500	241 501	242 302 (Filter only)
AIR LUBRICATOR	240 400	241 401	242 402



950 303



950 304

CONNECTION ADAPTERS

945 590, 1/4" BSP (MM).

945 592, 3/8" BSP (MM).

945 558, 1/2" BSP (MM).

945 551, 3/4" BSP (MM).

945 555, 1" BSP (MM).

945 724, 1 1/2" BSP (MM).

945 681, 1 1/2" BSP (M) - 1" BSP (M).

945 552 1" BSP (M) - 3/4" BSP (M).

945 554, 3/4" BSP (M) - 1/2" BSP (M).

945 557, 1/2" BSP (M) - 3/8" BSP (M).

945 567, 2" BSP (M) - 1 1/2" BSP (M).

945 565, 2" BSP (M) - 1" BSP (F).

945 513, 1 1/4" BSP (M) - 3/4" BSP (F).

945 670, 1" BSP (M) - 3/4" BSP (F).

369 900, 3/4" BSP (M) - 1/2" BSP (F).

945 556, 1/2" BSP (M) - 3/8" BSP (F).

369 601, 1/2" BSP (MM) 45° elbow.

945 572, 3/4" BSP (MF) 90° elbow.

945 548, 1/2" BSP (MM) 90° elbow.

945 738, 3/4" BSP (M) - 3/4" BSP (F) 90° elbow.

LOW AND MEDIUM PRESSURE VALVES

950 305, 1/4" BSP (FF), 65 bar quarter turn valve.

950 320, 3/8" BSP (FF), 65 bar quarter turn valve.

950 300, 1/2" BSP (FF), 65 bar quarter turn valve.

950 303, 3/4" BSP (FF), 40 bar quarter turn valve.

950 306, 1" BSP (FF), 40 bar quarter turn valve.

950 312, 1-1/2" BSP (FF), 25 bar quarter turn valve.

950 308, 2" BSP (FF), 25 bar quarter turn valve.

HIGH PRESSURE VALVES

950 304, 1/2" BSP (FF), 500 bar quarter turn valve.

950 328, 3/4" BSP (FF), 400 bar quarter turn valve.

950 329, 1" BSP (FF), 350 bar quarter turn valve.

AIR LINE SHUTOFF VALVES

950 302, Needle air valve 1/4" BSP (FF).

950 321, Air valve 1/4" BSP (FF).

950 318, Air valve 3/8" BSP (FF).

950 319, Air valve 1/2" BSP (FF).

362 104

OIL HOSES



Manufactured in NBR with a steel reinforcement braid. With two swaged nuts and male-male adaptors on both ends.

362 100, 1 m x 1/2". Working pressure: 160 bar. Connection threads: 1/2" BSP (MM).

362 101, 1,5 m x 1/2". Working pressure: 160 bar. Connection threads: 1/2" BSP (MM).

362 102, 2 m x 1/2". Working pressure: 160 bar. Connection threads: 1/2" BSP (MM).

362 103, 3 m x 1/2". Working pressure: 160 bar. Connection threads: 1/2" BSP (MM).

362 104, 4 m x 1/2". Working pressure: 160 bar. Connection threads: 1/2" BSP (MM).

362 300, 1 m x 3/4". Working pressure: 100 bar. Connection threads: 3/4" BSP (MM).

362 301, 1,5 m x 3/4". Working pressure: 100 bar. Connection threads: 3/4" BSP (MM).

362 302, 1,8 m x 3/4". Working pressure: 100 bar. Connection threads: 3/4" BSP (MM).

362 303, 3 m x 3/4". Working pressure: 100 bar. Connection threads: 3/4" BSP (MM).

OIL PUMPS MOUNTING ACCESSORIES QUICK REFERENCE CHART

PUMP	PUMP MASTER 2	PUMP MASTER 2	PUMP MASTER 4	PUMP MASTER 4	PUMP MASTER 4S	PUMP MASTER 4S	PUMP MASTER 4S	PUMP MASTER 60	PUMP MASTER 60
RATIO	1:1	3:1	3:1	5:1	3:1	6:1	10:1	6:1	12:1
BUNG ADAPTOR	360 001	360 000	360 001	360 002	(1)	(1)	360 006	(1)	(1)
CONNECTION HOSE KIT	362 910	362 910	362 911	362 911	539 009	539 009	539 009	539 009	539 009
WALL MOUNTING BRACKET	360 102	360 102	360 102	360 102	360 132	360 132	360 132	360 132	360 132
FLOOR BRACKET	360 120	360 120	360 120	360 120	360 121	360 121	360 121	360 121	360 121
THERMAL RELIEF KIT	Not needed	609 007	609 007	609 007	609 007	609 008	609 008	609 008	609 008
AIR REGULATOR WITH GAUGE	240 200	240 200	241 201	241 201	241 201	241 201	241 201	241 201	241 201
AIR FILTER LUBRICATOR	240 500	240 500	241 501	241 501	241 501	241 501	241 501	241 501	241 501
FRL	240 000	240 000	241 001	241 001	241 001	241 001	241 001	241 001	241 001
AIRLINE SHUTOFF VALVE	950 302	950 321	950 318	950 318	950 319	950 319	950 319	950 319	950 319
FLUID SHUTOFF VALVE	950 303	950 303	950 303	950 303	950 303	950 303	950 328	950 303	950 328
SUCTION KIT (*)	367 000	367 000	367 000	367 000	(2)	(2)	367 016	(2)	(2)
QUICK AIR COUPLER	253 114	253 114	253 138	253 138	251 412	251 412	251 412	251 412	251 412
QUICK AIR CONNECTOR	259 014	259 014	259 038	259 038	255 312	255 312	255 312	255 312	255 312
AIR CONNECTION ACCESSORIES I.D.	1/4" - 6 mm	1/4" - 6 mm	3/8" - 8 mm	3/8" - 8 mm	1/2" - 12 mm	1/2" - 12,5 mm	1/2" - 12,5 mm	1/2" - 12,5 mm	1/2" - 12,5 mm

(*) Suction kit for 200 l drum. Pump bracket not included.

(1) Pump must be wall or floor mounted.

(2) SAMOA recommends using 1-1/2" x 2 m maximum length hose as suction kit. See page 24.

PUMP INSTALLATION RECOMMENDATIONS

- Always use a ball valve between the tank outlet and the suction hose.
- Always use a ball valve between the pump outlet hose and the fluid distribution line.

PUMP INSTALLATION EXAMPLES

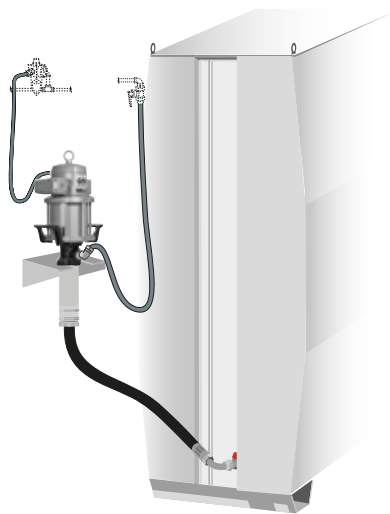

WALL MOUNTED PUMP



FLOOR MOUNTED PUMP



WALL MOUNTED PUMP

AIR OPERATED GREASE PUMPS	28
PUMPMASTER 3 - 55:1 RATIO GREASE PUMPS	30
PUMPMASTER 3+3 - 60:1 RATIO GREASE PUMPS	32
PUMPMASTER 3 AND PUMPMASTER 3+3 ACCESSORIES	35
PUMPMASTER 45 - 25:1 RATIO GREASE PUMP	37
PUMPMASTER 45 - 40:1 RATIO GREASE PUMPS	38
PUMPMASTER 45 - 70:1 RATIO GREASE PUMPS	39
PUMPMASTER 60 - 12:1 RATIO GREASE PUMP	40
PUMPMASTER 60 - 80:1 RATIO GREASE PUMPS	41
PUMPMASTER 45 & 60 INSTALLATION KITS	42
PUMPMASTER 45 & 60 GREASE PUMP KITS	43
GREASE PUMP ACCESSORIES	45





AIR OPERATED GREASE PUMPS

SAMOA offers a range of high pressure and high delivery grease pumps to handle a wide variety of applications. This pump offering fits original container sizes, from small pails to drums, totes and speciality built tanks, and covers applications from mobile and portable units to large distribution systems.

SAMOA's grease pumps are designed to provide years of dependable service. The in-line balanced design assures maximum pump efficiency. All Samoa pumps have a double acting design, pumping product on both the upstroke and downstroke. An effective priming piston provides positive pump, even when used with high viscosity or tacky greases. A hardened foot valve minimizes pump damage due to dirt. A corrosion proof air motor design tolerates moisture in compressed air.

PUMP MASTER®



	PUMPMASTER 3 - 55:1	PUMPMASTER 3+3 - 60:1
PUMP DESCRIPTION	Utility high pressure	Heavy Duty high pressure
SIMULTANEOUS OPERATION OUTLETS	1 No reels - mobile units	1 to 2
MAX. LINE LENGTH	15 m - 50'	75 m - 250'
APPLICATION	Agriculture Service shops Light Industrial	Heavy Duty service shops Fleets Lube trucks Mining and construction In-plant Railroad and mass transit

Maximum line length and number of simultaneous dispense points also depends on the line diameter, fluid viscosity and required delivery



PUMPMASTER 45 - 25:1	PUMPMASTER 45 - 40:1	PUMPMASTER 45 - 70:1	PUMPMASTER 60 - 12:1	PUMPMASTER 60 - 80:1
Intensive Duty pressure transfer	Intensive Duty high flow	Intensive Duty high pressure	Intensive Duty volume transfer	Intensive Duty high performance
1 No reels - mobile units	4 or more	4 or more	1 High volume transfer	4 or more
75 m - 250'	125 m - 400'	175 m - 600'	50 m - 175'	250 m - 800'
Moderate pressure transfer Lube trucks Mining and construction In-plant	Heavy Duty service shops Fleets Lube trucks Mining and construction Railroad and mass transit In-plant Marine	Heavy Duty service shops Fleets Lube trucks Mining and construction Railroad and mass transit In-plant Marine	Low pressure, high volume transfer Mining and construction In-plant Railroad and mass transit	Fleets Lube trucks Mining and construction Railroad and mass transit In-plant Marine

Maximum line length and number of simultaneous dispense points also depends on the line diameter, fluid viscosity and required delivery

407 200

UTILITY HIGH PRESSURE PUMPS

Light weight and effective high pressure delivery air operated pumps specially designed for use in mobile and portable greasing units.

Pumps are available with four different suction tube lengths, to fit all commercial grease drums: 12,5 - 20 kg (40 lb), 50 kg (120 lb) and 185 kg (400 lb). They include a height adjustable 2" BSP (M) bung adaptor.



FLUIDS HANDLED

- Grease up to NLGI-2.

MARKETS SERVED

- Agriculture.
- Service shops.
- Light industrial.

MODELS				
PART No.	APPLICATION	PUMP TUBE HEIGHT	TOTAL HEIGHT	WEIGHT
404 100	12,5 - 20 kg (40 lb) pails	410 mm	650 mm	3,5 kg
405 100	50 kg (120 lb) drums	510 mm	710 mm	3,7 kg
407 200	50 kg (120 lb) drums	725 mm	925 mm	4,3 kg
409 200	185 kg (400 lb) drums	920 mm	1.120 mm	4,8 kg

TECHNICAL DATA	
Pump pressure ratio	55:1
Air pressure operating range	1,5 to 10 bar (20 to 140 psi)
Air consumption ⁽¹⁾	165 NL/min (5.8 cfm)
Maximum fluid outlet pressure	550 bar (7,700 psi)
Air motor diameter	70 mm (2.75")
Air motor stroke	35 mm (1.4")
Delivery at 110 cpm	300 g/min (0.67 lb/min)
Maximum free flow delivery ⁽²⁾	540 g/min (1.2 lb/min)
Air inlet	1/4" NPSM (F)
Fluid outlet	1/4" NPSM (F)
Wetted and seal materials	Steel / NBR / PTFE
Noise level ⁽³⁾	92 dB

(1) Maximum air consumption with 6 bar air inlet pressure, NLGI-2 grease at 20 °C and 100 cpm.

(2) Maximum free delivery at 7 bar. NLGI-2 grease.

(3) Maximum noise level measured at 1 m from the pump, 7 bar air pressure and free delivery.

NLGI-2, 20 °C (68 °F) CAPACITY

MODEL	DIMENSIONS (MM)			
	404 100	405 100	407 200	409 200
A (mm)	650	710	925	1.120
B (mm)	200	200	200	200
C (mm)	26	26	26	26
D (mm)	410	510	725	920
E (mm)	38	38	38	38

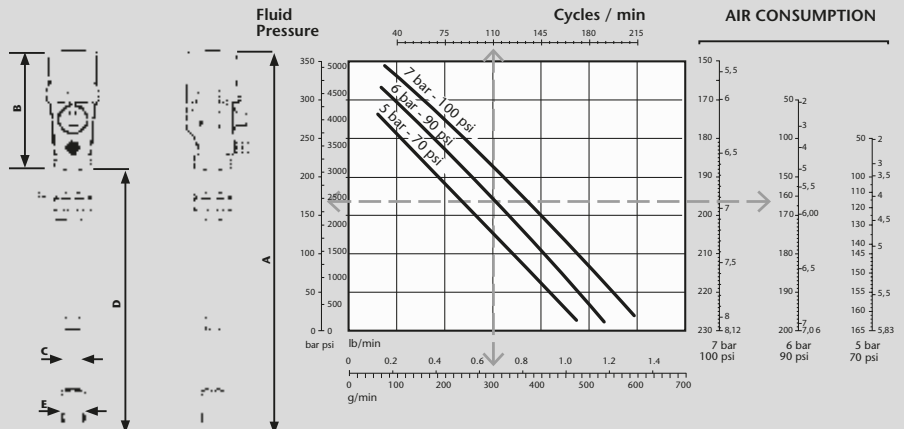

424 172 - 424 152

482 200

425 150.002

428 243

Mobile and portable units to fit 18, 20, 50 and 185 kg drums.



Part No.	APPLICATION	PUMP	DRUM COVER	FOLLOWER PLATE	DELIVERY HOSE	GREASE GUN WITH Z-SWIVEL	TROLLEY
424 150	Mobile unit, 12,5 to 18 kg (1)	404 100	418 013	-	2 m x 1/4" 412 102	413 080	430 000
424 152	Mobile unit, 20 kg (1)	404 100	418 002	-	2 m x 1/4" 412 102	413 080	430 000
424 170	Portable unit, 12,5 to 18 kg (1)	404 100	418 013	-	2 m x 1/4" 412 102	413 080	-
424 170.800	Portable unit, 12,5 to 18 kg (1)	404 100	418 013	417 001	2 m x 1/4" 412 102	413 080	-
424 172	Portable unit, 20 kg (1)	404 100	418 002	-	2 m x 1/4" 412 102	413 080	-
424 172.710	Portable unit, 20 kg (1)	404 100	418 002	417 001	2 m x 1/4" 412 102	413 080	-
482 200	Mobile unit, 12,5 to 20 kg (2)	404 100	-	-	2 m x 1/4" 412 102	413 080	480 021
425 150	Mobile unit, 50 kg drum	407 200	418 004	-	3 m x 1/4" 412 103	413 080	431 000
425 150.002	Mobile unit, 50 kg drum	407 200	418 004	417 002	3 m x 1/4" 412 103	413 080	431 000
425 290	Mobile unit, 50 kg drum	407 200	418 004	-	2 m x 1/4" 412 102	413 080	430 000
482 500	Mobile unit, 50 kg drum (3)	407 200	-	-	3 m x 1/4" 412 103	413 080	480 050
428 243	Mobile unit, 185 kg drum	409 200	418 006	417 004	4 m x 1/4" 412 104	413 080	432 000
428 262	Stationary unit, 185 kg drum	409 200	418 006	417 004	4 m x 1/4" 412 104	413 080	-

(1) Includes carrying handle 741 602.

(2) Shielded unit. Includes base with 4 castors.

(3) Shielded unit. Includes base with 2 wheels and 2 castors.

Not included options:

239 000: 1/4" BSP (MM) connection adaptor.

240 500: Air filter and pressure regulator, 0-12 bar, 1/4" BSP (FF).

417 001: Follower plate 298 - 260 mm. For 12,5 and 18 kg pails.

417 002: Follower plate 370 - 330 mm. For 50 kg standard diameter drums.

417 003: Follower plate 405 - 360 mm. For 50 kg large diameter drums.

417 005: Follower plate 340 - 300 mm. For 20 kg pails.

411 100: In-line grease meter for grease control gun.

402 000

HEAVY DUTY HIGH PRESSURE PUMPS



Heavy Duty double acting pumps that combine high pressure (60:1 pressure ratio) and volume delivery. Recommended for use in distribution and greasing systems that include pipe lines, hose reels, etc. with up to 2 simultaneous use outlets even though the number of outlets in the system can be higher. Very reliable pump, it has a removable screen filter at the grease intake for eliminating dirt and impurities that could damage the pump, and a built in filter at the air inlet connection. Includes a height adjustable 2" BSP (M) bung adaptor.

FLUIDS HANDLED

- Grease up to NLGI-2.

MARKETS SERVED

- Heavy duty service shops.
- Fleet service.
- Lube trucks.
- Mining and construction.
- In-plant.
- Railroad and mass transit.

MODELS				
PART No.	APPLICATION	PUMP TUBE HEIGHT	TOTAL HEIGHT	WEIGHT
402 050	12,5 - 20 kg (40 lb) pails	516 mm	806 mm	6,5 kg
402 000	50 kg (120 lb) drum	730 mm	1.020 mm	7,5 kg
402 025	185 kg (400 lb) drum	925 mm	1.215 mm	8,5 kg

TECHNICAL DATA	
Pump pressure ratio	60:1
Air pressure operating range	1,5 to 10 bar (20 to 140 psi)
Air consumption ⁽¹⁾	475 NI/min (16.8 cfm)
Maximum fluid outlet pressure	600 bar (8,400 psi)
Air motor diameter	75 mm (3")
Air motor stroke	75 mm (3")
Delivery at 100 cpm	500 g/min (1.1 lb/min)
Maximum free flow delivery ⁽²⁾	1.200 g/min (2.6 lb/min)
Air inlet	3/8" NPSM (F)
Fluid outlet	3/8" NPSM (F)
Wetted and seal materials	Steel / PTFE / Polyurethane
Noise level ⁽³⁾	92 dB

(1) Maximum air consumption with 7 bar air inlet pressure, NLGI-2 grease at 20 °C and 100 cpm.

(2) Maximum free delivery at 7 bar. NLGI-2 grease.

(3) Maximum noise level measured at 1 m from the pump, 7 bar air pressure and free delivery.

DIMENSIONS (mm)			
MODEL	402 050	402 000	402 025
A (mm)	806	1.020	1.215
B (mm)	290	290	290
C (mm)	30	30	30
D (mm)	516	730	925

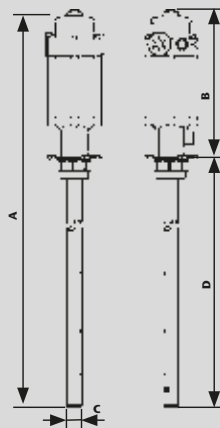

NLGI-2, 20 °C (68 °F) CAPACITY

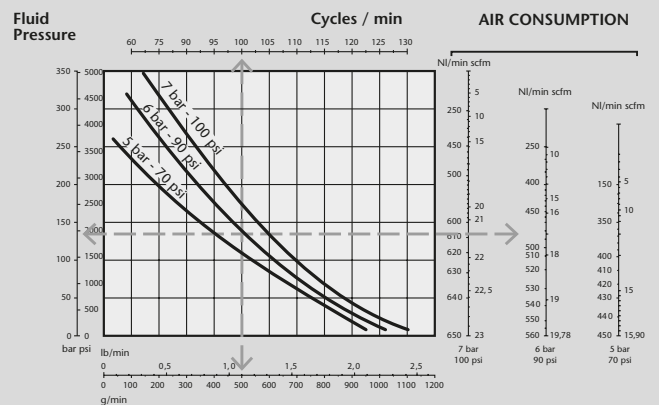

PUMPMASTER 3+3 60:1 RATIO PUMP KITS



429 800

429 810 Pumpmaster 3+3 60:1 ratio pump kit for 50 kg drums
Includes 60:1 ratio pump for 50 kg drums 402 000 with drum cover for 50 kg drum 418 004 and hose connection kit 412 920.

429 800 Pumpmaster 3+3 60:1 ratio pump kit for 185 kg drums
Includes 60:1 ratio pump for 185 kg drums 402 025 with drum cover for 185 kg drum 418 006, follower plate for 185 kg drums 417 004 and hose connection kit 412 920.



453 602



426 243



486 500



423 150

PUMPMASTER 3+3 60:1 RATIO PACKAGES FOR 185 KG AND 50 KG DRUMS

	PUMP AND HOSE REEL PACKAGE FOR 185 KG DRUMS	MOBILE PACKAGE FOR 185 KG DRUMS	MOBILE PACKAGE FOR 50 KG DRUMS	MOBILE PACKAGE FOR 50 KG DRUMS
PART No.	453 602	426 243	486 500	423 150
PUMP	402 025	402 025	402 000	402 000
DRUM COVER	418 006	418 006	-	418 013
FOLLOWER PLATE	417 004	417 004	-	-
HOSE CONNECTION KIT	412 920	-	-	-
GREASE GUN WITH Z-SWIVEL	413 080	413 080	413 080	413 080
DELIVERY HOSE	15 m Hose reel 504 301	4 m x 1/4" 412 104	3 m x 1/4" 412 103	3 m x 1/4" 412 103
DRUM TROLLEY	-	432 000	480 050 ⁽¹⁾	431 000

(1) Shielded unit. Includes base with 2 wheels and 2 castors.

Not included options:

- 239 001:** 1/4" BSP (M) - 3/8" BSP (M) connection adaptor.
- 240 500:** Air filter and pressure regulator, 1/4" BSP (FF).
- 360 111:** Hose reel pivoting bracket.
- 360 127:** Control gun holder and drip tray.
- 417 002:** Follower plate 370 - 330 mm. For 50 kg standard diameter drums.
- 417 003:** Follower plate 405 - 360 mm. For 50 kg large diameter drums.
- 411 100:** In line grease meter for grease control gun.

486 200 - 423 020

PUMPMASTER 3+3 60:1 RATIO PACKAGES FOR 18 KG AND 20 KG PAILS

02
GREASE PUMPS



	MOBILE PACKAGE FOR 20 KG PAILS	PORTABLE PACKAGE FOR 18 KG PAILS
PART No.	486 200	423 020
PUMP	402 050	402 050
DRUM COVER	-	418 013
FOLLOWER PLATE	-	417 001
GREASE GUN WITH Z SWIVEL	413 080	413 080
DELIVERY HOSE	2 m x 1/4" 412 102	2 m x 1/4" 412 102
DRUM TROLLEY	480 021 ⁽¹⁾	-

(1) Shielded unit. Includes base with 4 castors.

424 060

MOBILE EXTRUSION UNIT FOR 12-20 KG PAILS



Mobile unit specially designed for its use with hard to pump sticky and high viscosity greases (up to NLGI3).

The pump's lower end is fixed to an inductor plate and the pump is mounted to a pneumatic piston that elevates the pump for replacing an empty pail. The pneumatic piston also acts when the pump is in use, pushing the inductor plate against the grease, aiding the pump prime, making possible to pump very high viscosity grease. Follower plate increases productivity as it eliminates air pockets and contributes to maintain grease free from dirt in industrial environments. The air cylinder is controlled with a valve located on the top of the inductor post and it includes a pressure regulator to adjust the downward pressure.

The unit includes a PM 3+3 60:1 pressure ratio pump and it is mounted to a rolling base with 4 wheels, two of them with brake.

424 060 Mobile extrusion unit

Includes 3 m high pressure hose and a grease control gun with Z-swivel and hydraulic nozzle.

424 061 Mobile extrusion unit

Same as model 424 060 but with no outlet hose and grease control gun.

Air filter and regulator (PN 240 500) is non included option.

Not included options:

239 001: 1/4" BSP (M) - 3/8" BSP (M) connection adaptor.

240 500: Air filter and pressure regulator, 1/4" BSP (FF).

417 001: Follower plate 298 - 260 mm. For 12,5 and 18 kg pails.

417 005: Follower plate 340 - 300 mm. For 20 kg pails.

411 100: In line grease meter for grease control gun.

418 004 - 417 003

DRUM COVERS AND FOLLOWER PLATES

Drum covers. Very solid construction. With 2" BSP (F) bung opening.



PART No.	DRUM TYPE	DRUM EXTERNAL DIAMETER (MIN. - MAX.)
418 013	12,5 to 18 kg pails	265 - 310 mm
418 002	20 kg pails	285 - 330 mm
418 016	50 kg drums	350 - 395 mm
418 004	50 kg drums	360 - 405 mm
418 006	185 kg drums	565 - 610 mm

Follower plates eliminate air pockets and aid pump prime. Rubber flange minimizes waste. With handle for removing from empty drums.

PART No.	DRUM TYPE	DRUM EXTERNAL DIAMETER (MIN. - MAX.)
417 006	12,5 kg pails	190 - 260 mm
417 001	12,5 to 18 kg pails	260 - 298 mm
417 005	20 kg pails	300 - 340 mm
417 002	50 kg drums	330 - 370 mm
417 003	50 kg drums	360 - 405 mm
417 004	185 kg drums	550 - 590 mm

430 000 - 431 000 - 432 814 - 432 000

DRUM TROLLEYS



430 000 Trolley for 20 kg pails

Two wheel trolley with tubular frame for 20 and 50 kg drums.

431 000 Trolley for 50 and 20 kg drums

Four wheel trolley with tubular frame.

431 001 Trolley for 50 and 20 kg drums

Two wheel and two front rubber pads trolley with tubular frame.

480 050 Mobile protective drum cabinet, 50 kg

480 021 Mobile protective drum cabinet, 20 kg

432 000 Trolley for 185 kg drum.

Two solid rubber wheels and one swivelling rubber wheel with brake. A hose reel and a pump can be, mounted using optional bracket.

360 134 Pump bracket

For mounting a short pump to trolley 432 000.

360 135 Hose reel bracket

For mounting a hose reel to trolley 432 000.

432 814 Heavy Duty trolley for 185 kg drum

Two 260 mm front tires and one swivelling solid rubber wheel with brake. A hose reel can be, mounted using optional bracket.

360 113 Hose reel bracket.

For mounting a hose reel to trolley 432 814.

INTENSIVE DUTY PISTON PUMPS: THE HEART OF A LUBRICATION SYSTEM

Samoa Intensive Duty pumps are designed to deliver through long distribution lines or to multiple dispensing points with simultaneous operation all kind of grease at continuous duty and high flow rates under extreme and intensive working conditions.

These double acting, high efficiency, air powered, positive displacement piston pumps provide the necessary confidence to offer solutions for moving fast the required volume of grease with the right pressure in very large distance applications.

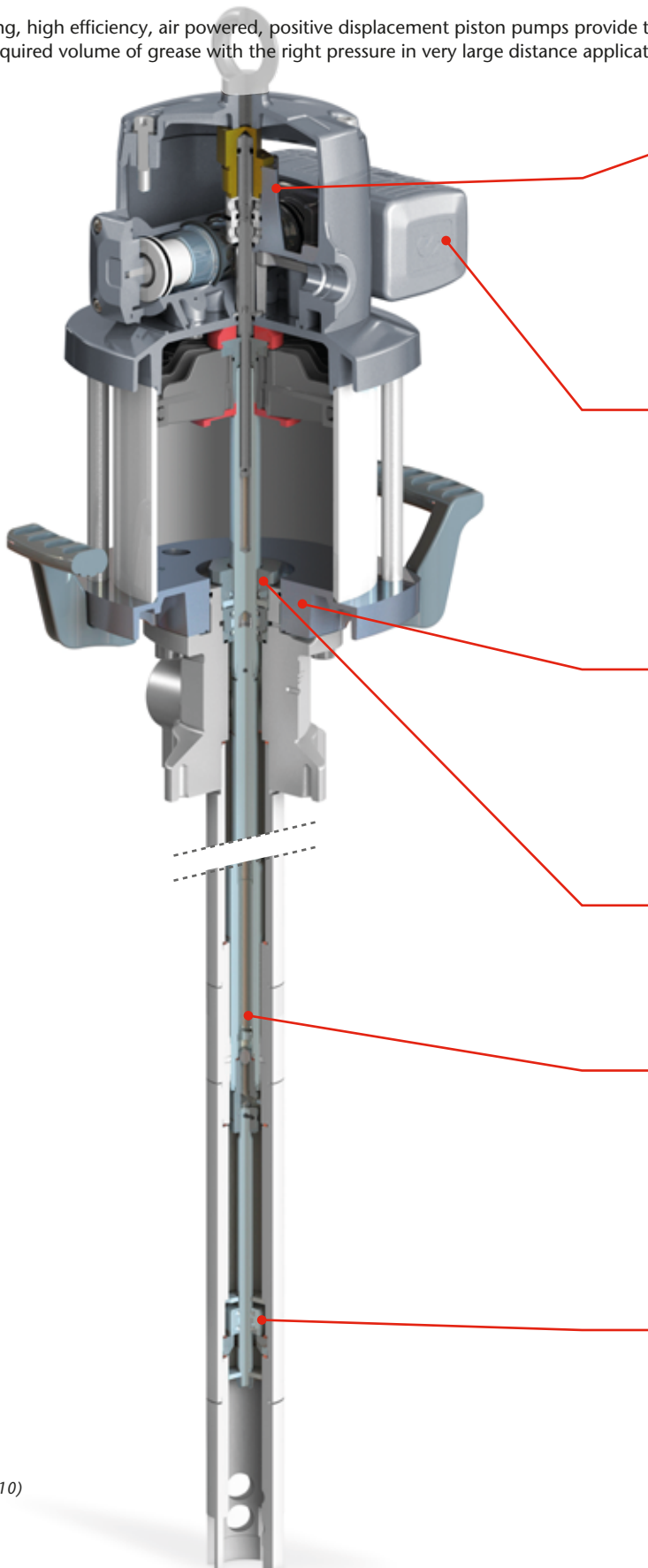

Pneumatic air motors. Mechanically driven air motors offer the reliability and dependability required for assuring a non-stalling and superb performance under every working condition. The very simple air valve has no energy consuming springs that could fail due to material fatigue or pneumatic end of stroke sensors that could get to locked because of dirty air.

Air exhaust. The well dimensioned air exhaust design manufactured, in efficient heat dissipation aluminium eliminates erratic pump performance and ice formation at the air exhaust. The air exhaust includes a muffler to reduce noise levels to meet or exceed OSHAS requirements. The muffler can be removed for connecting a hose to the exhaust port for expanding the air to a remote location.

Modular design. Tough modular pump design allows multiple combination assemblies of air motor and lower pump end. This versatile pump construction, for easy service and maintenance, provides a comprehensive range of operating output pressures and flow-rates to meet any amount of grease and pressure demanded in each application.

Pump top gland seal. The anti-corrosive, hardened plunger and the cartridge seals packing arrangements are designed for low friction, to minimize wear and to maximize tightness and seals life.

High quality materials. Aluminium die-cast pneumatic air motor with hard anodized aluminium cylinder; light weight drive piston and plunger with rubber-PTFE or polyurethane seals; cast outlet body, thick-wall polished tube, high tensile steel on rod; barrel, piston and prime valve made of special hardened, precision fitted, ground steel for perfect seal and long life of grease pumps.

Pump inlet valve. Samoa offers a chop-check priming valve that assists the entry of heavy and sticky high viscosity grease into the pump and improves pump efficiency. PM45-25:1 ratio pump is double ball valve design pump for the transfer of grease up to NLGI-1.

PM 60 - 80 MA (532 810)

531 210

INTENSIVE DUTY PRESSURE TRANSFER PUMP

Moderate pressure, high delivery double acting pumps for transfer of grease up to NLGI-2. Also recommended for use with low viscosity grease in centralized grease systems that do not require a very high pressure output and in large distribution systems of high viscosity oils.

Pumps are available with tube length to fit commercial 185 kg - 400 lb drums and they are available for cover mount to 185 kg - 400 lb open drums using a drum cover 418 017.



FLUIDS HANDLED

- Grease up to NLGI-2
- High viscosity oil.

MARKETS SERVED

- Lube trucks.
- Mining and construction.
- In-plant.

MODELS				
PART No.	APPLICATION	PUMP TUBE HEIGHT	TOTAL HEIGHT	WEIGHT
531 210	185 kg (400 lb) drum	855 mm	1.357 mm	24 kg

TECHNICAL DATA	
Pump pressure ratio	25:1
Continuous duty flow rate	6 kg/min (13.2 lb/min)
Maximum free flow	16 kg/min (35.3 lb/min)
Air pressure operating range	1,5 - 14 bar (20 - 200 psi)
Maximum outlet pressure	350 bar (5,000 psi)
Air motor effective diameter	115 mm (4.5")
Air motor stroke	100 mm (4")
Air consumption ⁽¹⁾	1.340 NI/min (47 cfm)
Air inlet	1/2" BSP (F)
Fluid outlet	1/2" BSP (F)
Wetted and seals materials	Cast Iron / Steel / Hard chromed steel / UHMWPE / NBR
Noise level ⁽²⁾	80 dB

(1) Air consumption at 5 bar air pressure, NLGI-0 grease at 20 °C and 80 cpm.
 (2) Noise level measured at 1 m from the pump, 7 bar air pressure and free delivery.

DIMENSIONS (MM)	
MODEL	531 210
A (mm)	1.357
B (mm)	502
C (mm)	50
D (mm)	855

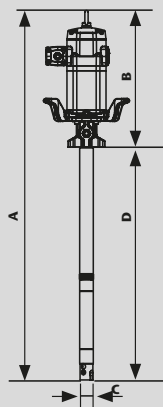

NLGI-0, 21 °C (70 °F) CAPACITY

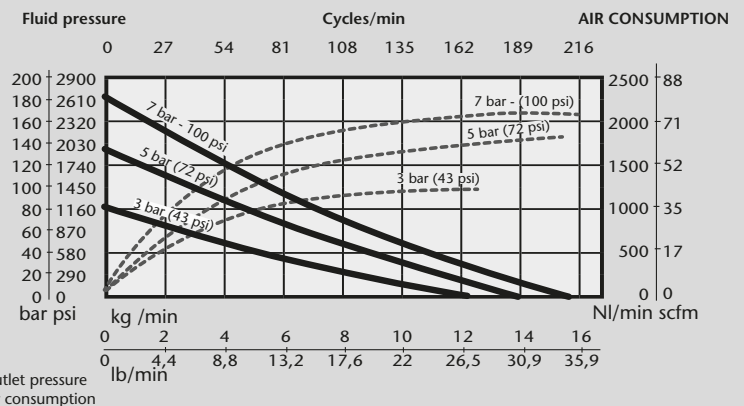

531 410

INTENSIVE DUTY HIGH FLOW PUMPS

02
GREASE PUMPS

High flow double acting pumps with high pressure delivery for use in lubrication systems that require a combination of high flow and pressure delivery. Pumps can be used with grease up to NLGI-2 viscosity. These pumps can be used in medium length systems that include simultaneous operation outlets.

Pumps are available for cover mount to 50 kg - 120 lb and 185 kg - 400 lb open drums and for horizontal and side mount on grease totes and bags.



FLUIDS HANDLED

- Grease up to NLGI-2.

MARKETS SERVED

- Heavy Duty service shops.
- Fleets.
- Mining and construction.
- Railroad and mass transit.
- In-plant.
- Marine.

MODELS				
PART No.	APPLICATION	PUMP TUBE HEIGHT	TOTAL HEIGHT	WEIGHT
531 410	185 kg (400 lb) drum	855 mm	1.357 mm	25 kg
531 420	50 kg (120 lb) drum	650 mm	1.152 mm	22 kg
531 430*	Bulk tote	490 mm	992 mm	26 kg

* Includes adaptor 753 110 to fit a 3" cam-lock connector for use in totes and grease bags.

TECHNICAL DATA	
Pump pressure ratio	40:1
Continuous duty flow rate	3,5 kg/min (7.5 lb/min)
Maximum free flow	11 kg/min (24.3 lb/min)
Air pressure operating range	1,5 - 14 bar (20 - 200 psi)
Maximum outlet pressure	560 bar (8,000 psi)
Air motor effective diameter	115 mm (4.5")
Air motor stroke	100 mm (4")
Air consumption ⁽¹⁾	750 NI/min (26.5 cfm)
Air inlet	1/2" BSP (F)
Fluid outlet	1/2" BSP (F)
Wetted and seals materials	Cast Iron / Steel / Hard chromed steel / UHMW PE / NBR / PTFE
Noise level ⁽²⁾	80 dB

(1) Air consumption at 5 bar air pressure, NLGI-2 grease at 20 °C and 80 cpm.

(2) Noise level measured at 1 m from the pump, 7 bar air pressure and free delivery.

DIMENSIONS (MM)			
MODEL	531 410	531 420	531 430*
A (mm)	1.357	1.152	992
B (mm)	502	502	502
C (mm)	50	50	50
D (mm)	855	650	490
E (mm)	-	-	410

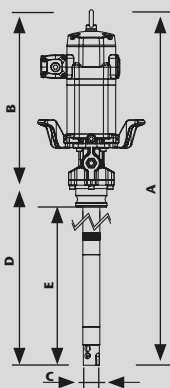

NLGI-2, 21 °C (70 °F) CAPACITY

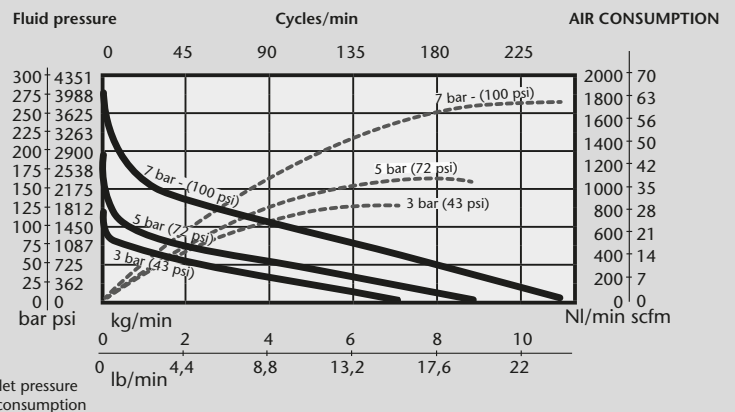

531 710

INTENSIVE DUTY HIGH PRESSURE PUMPS

High pressure double acting pump for use in applications that require extra pressure output or when cold temperatures a low air pressure could limit pump performance. Pumps can be used with grease up to NLGI-2 viscosity. These pumps can be used in large distribution systems that include simultaneous operation outlets.

Pumps are available for cover mount to 50 kg - 120 lb and 185 kg - 400 lb open drum and for horizontal and side mount on grease totes and bags.



FLUIDS HANDLED

- Grease up to NLGI-2.

MARKETS SERVED

- Heavy Duty service shops.
- Fleets.
- Lube trucks.
- Mining and construction.
- Rail road and mass transit.
- In-plant.
- Marine.

MODELS				
PART No.	APPLICATION	PUMP TUBE HEIGHT	TOTAL HEIGHT	WEIGHT
531 710	185 kg (400 lb) drum	855 mm	1.357 mm	25 kg
531 720	50 kg (120 lb) drum	650 mm	1.152 mm	22 kg
531 730*	Bulk tote	490 mm	992 mm	21 kg

* Includes adaptor 753 110 to fit a 3" cam-lock connector for use in totes and grease bags.

TECHNICAL DATA	
Pump pressure ratio	70:1
Continuous duty flow rate	2 kg/min (4.5 lb/min)
Maximum free flow	7,5 kg/min (16.5 lb/min)
Air pressure operating range	1,5 - 7 bar (20 - 100 psi)
Maximum outlet pressure	490 bar (7,000 psi)
Air motor effective diameter	115 mm (4.5")
Air motor stroke	100 mm (4")
Air consumption ⁽¹⁾	925 NI/min (32.6 cfm)
Air inlet	1/2" BSP (F)
Fluid outlet	1/2" BSP (F)
Wetted and seals materials	Cast Iron / Steel / Hard chromed steel / UHMW PE / NBR / PTFE
Noise level ⁽²⁾	80 dB

(1) Air consumption at 5 bar air pressure, NLGI-2 grease at 20 °C and and 80 cpm.

(2) Noise level measured at 1 m from the pump, 7 bar air pressure and free delivery.

DIMENSIONS (MM)			
MODEL	531 710	531 720	531 730*
A (mm)	1.357	1.152	992
B (mm)	502	502	502
C (mm)	50	50	50
D (mm)	855	650	490
E (mm)	-	-	410

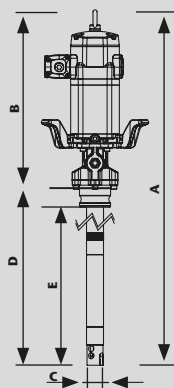
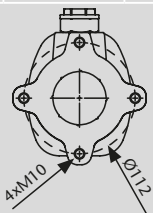

NLGI-2, 21 °C (70 °F) CAPACITY

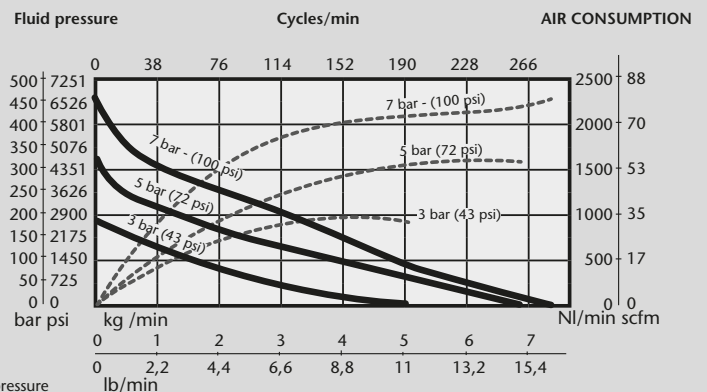

532 130

INTENSIVE DUTY VOLUME TRANSFER PUMP

Moderate pressure, very high volume double acting grease pump for use in transfer applications. These pumps can be used with all type of grease up to NLGI-2.

Pumps are available for horizontal mounting on grease totes and grease bags and they include an adaptor to fit a 3" Cam-Lock coupler. They can be used with 185 kg - 400 lb drums when mounted to air pneumatic inductor (see "Grease pump kits" section in this chapter.)

02 GREASE PUMPS



FLUIDS HANDLED

- Grease up to NLGI-2.

MARKETS SERVED

- Mining and construction.
- In-plant grease transfer.
- Rail road and mass transit.

MODELS				
PART No.	APPLICATION	PUMP TUBE HEIGHT	TOTAL HEIGHT	WEIGHT
532 130*	Bulk tote	226 mm	742 mm	19 kg

* Includes adaptor 753 110 to fit a 3" cam-lock connector for use in totes and grease bags.

TECHNICAL DATA	
Pump pressure ratio	12:1
Continuous duty flow rate	15 kg/min (33 lb/min)
Maximum free flow	40 kg/min (88 lb/min)
Air pressure operating range	1,5 - 7 bar (20 - 100 psi)
Maximum outlet pressure	84 bar (1,200 psi)
Air motor effective diameter	150 mm (6")
Air motor stroke	100 mm (4")
Air consumption ⁽¹⁾	1.100 NI/min (39 cfm)
Air inlet	1/2" BSP (F)
Fluid outlet	1" BSP (F)
Wetted and seals materials	Cast Iron / Steel / Hard chromed steel / UHMWPE / NBR / PTFE / Polyurethane
Noise level ⁽²⁾	80 dB

(1) Air consumption at 5 bar air pressure, NLGI-2 grease at 20 °C and 60 cpm.

(2) Noise level measured at 1 m from the pump, 7 bar air pressure and free delivery.

DIMENSIONS (mm)	
MODEL	532 130
A (mm)	742
B (mm)	516
C (mm)	70
D (mm)	226
E (mm)	146

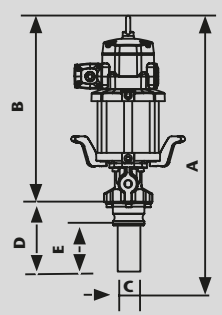
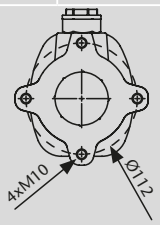

NLGI-2, 21 °C (70 °F) CAPACITY

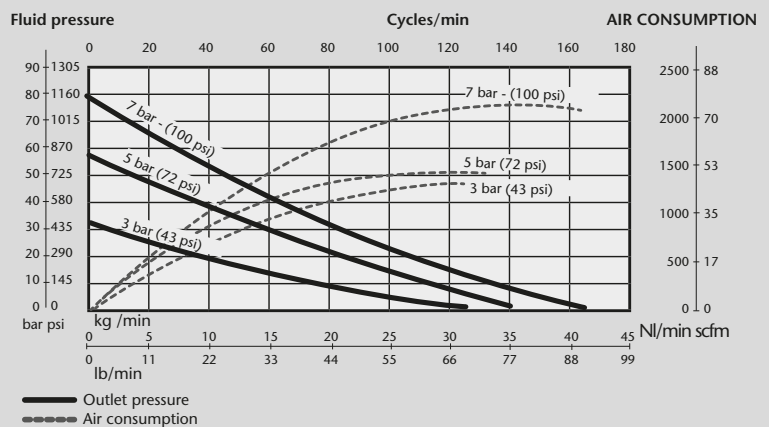

Very high pressure and high volume delivery double acting pump for use in applications that require extra pressure and volume output and where cold temperatures or low air pressure could limit pump performance. Pumps can be used with grease up to NLGI-2 viscosity. These pumps can be used in large distribution systems that include simultaneous operation outlets. Pumps are available for cover mount to 50 kg - 120 lb and 185 kg - 400 lb open drum and for side mount on grease totes.

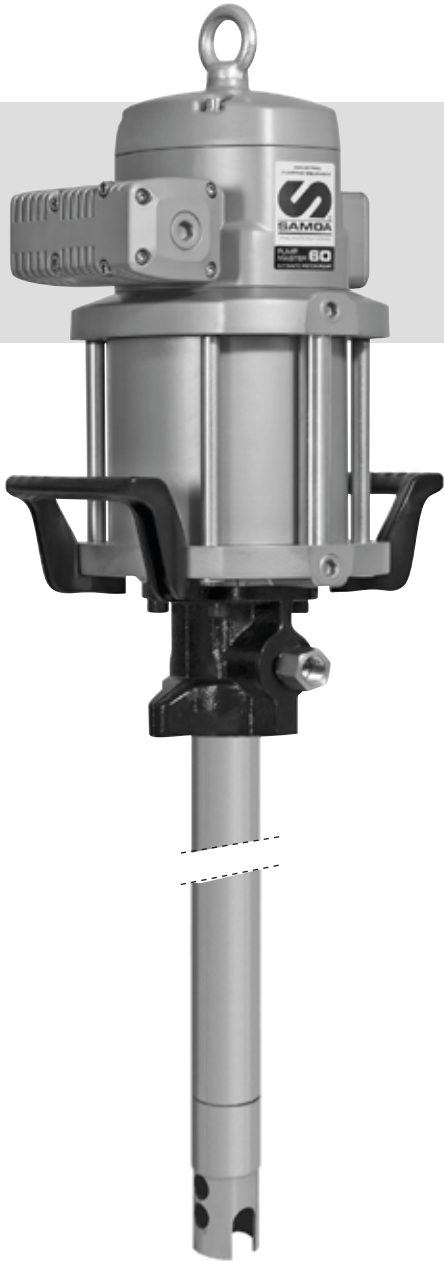

FLUIDS HANDLED

- Grease up to NLGI-2.

MARKETS SERVED

- Mining and construction.
- In-plant.
- Railroad and mass transit.
- Lube trucks.
- Fleets.

MODELS				
PART No.	APPLICATION	PUMP TUBE HEIGHT	TOTAL HEIGHT	WEIGHT
532 810	185 kg (400 lb) drum	855 mm	1.371 mm	27 kg
532 820	50 kg (120 lb) drum	650 mm	1.166 mm	24 kg

TECHNICAL DATA	
Pump pressure ratio	80:1
Continuous duty flow rate	2,5 kg/min (5.5 lb/min)
Maximum free flow	8 kg/min (17.6 lb/min)
Air pressure operating range	1,5 - 7 bar (20 - 100 psi)
Maximum outlet pressure	560 bar (8,000 psi)
Air motor effective diameter	150 mm (6")
Air motor stroke	100 mm (4")
Air consumption ⁽¹⁾	1.000 NI/min (35 cfm)
Air inlet	1/2" BSP (F)
Fluid outlet	1/2" BSP (F)
Wetted and seals materials	Cast Iron / Steel / Hard chromed steel / UHMW PE / NBR / PTFE
Noise level ⁽²⁾	80 dB

(1) Air consumption at 5 bar air pressure, NLGI-2 grease at 20 °C and 60 cpm.
 (2) Noise level measured at 1 m from the pump, 7 bar air pressure and free delivery.

DIMENSIONS (MM)		
MODEL	532 810	532 820
A (mm)	1.371	1.166
B (mm)	516	516
C (mm)	50	50
D (mm)	855	650

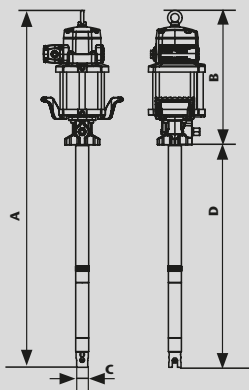
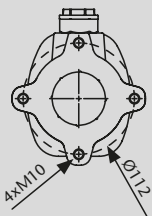

NLGI-2, 21 °C (70 °F) CAPACITY

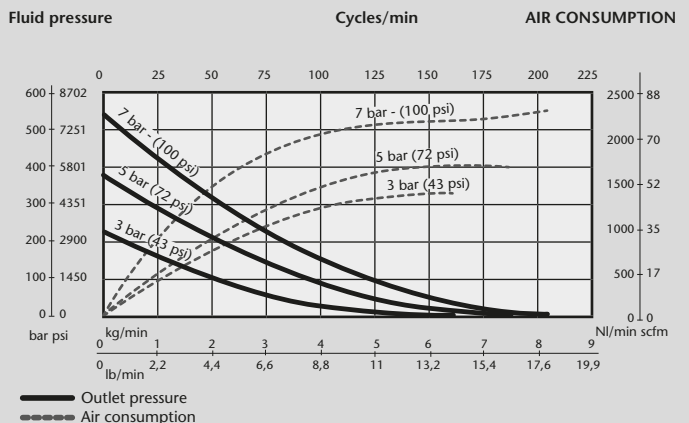

PUMPMASTER 45 & 60 INSTALLATION KITS

534 710

PUMPMASTER 45 INSTALLATION KITS

PM45 pump kits for 50 kg and 185 kg drums, totes and grease bins.

02
GREASE PUMPS



	KIT PART NO.	PUMP	RATIO	COVER	FOLLOWER PLATE	CONNECTION KIT	CAMLOCK FEMALE	CAMLOCK MALE
50 KG DRUM MOUNTED PUMP KIT	534 420	531 420	40:1	418 017	(1)	534 103	-	-
	534 720	531 720	70:1	418 017	(1)	534 103	-	-
185 KG DRUM MOUNTED PUMP KIT	534 410	531 410	40:1	418 026	417 009	534 103	-	-
	534 710	531 710	70:1	418 026	417 009	534 103	-	-
	534 210	531 210	25:1	418 026	417 009	534 103	-	-
TANK SIDE MOUNTED PUMP KIT	534 240	531 210	25:1	-	-	534 103	950 358	753 110
	534 440	531 410	40:1	-	-	534 103	950 358	753 110
	534 740	531 710	70:1	-	-	534 103	950 358	753 110
TANK HORIZONTAL MOUNTED PUMP KIT	534 441	531 430	40:1	-	-	534 103	950 358	(2)
	534 741	531 730	70:1	-	-	534 103	950 358	(2)

(1) Use follower plate 417 010 or 417 011 as required. Follower plate not included.
 (2) Included with pump.

SAMOA recommends using an air filter and pressure regulator at the pump air inlet and a high pressure needle valve between the grease delivery hose and the grease distribution line.

534 141

PUMPMASTER 60 INSTALLATION KITS

PM60 pump kits for 50 kg and 185 kg drums, totes and grease bins.

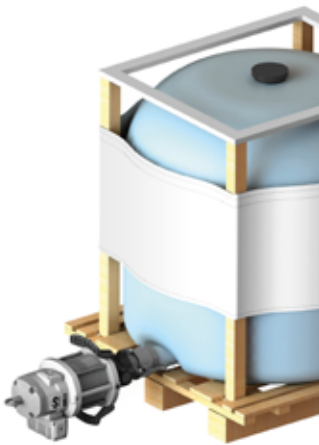

	KIT PART No.	PUMP	RATIO	COVER	FOLLOWER PLATE	CONNECTION KIT	CAMLOCK FEMALE	CAMLOCK MALE
50 kg DRUM MOUNTED PUMP KIT	534 820	532 820	80:1	418 017	(1)	534 103	-	-
185 kg DRUM MOUNTED PUMP KIT	534 810	532 810	80:1	418 026	417 009	534 103	-	-
TANK SIDE MOUNTED PUMP KIT	534 840	532 810	80:1	-	-	534 103	950 358	753 110
TANK HORIZONTAL MOUNTED PUMP KIT	534 141	532 130	12:1	-	-	539 009	950 358	(2)

(1) Use follower plate 417 010 or 417 011 as required. Follower plate not included.
 (2) Included with pump.

SAMOA recommends using an air filter and pressure regulator at the pump air inlet and a high pressure needle valve between the grease delivery hose and the grease distribution line.

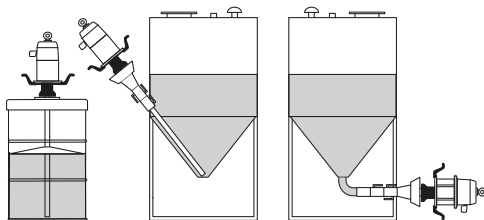

DRUM MOUNTED PUMP

TANK SIDE MOUNT PUMP

TANK HORIZONTAL MOUNT PUMP

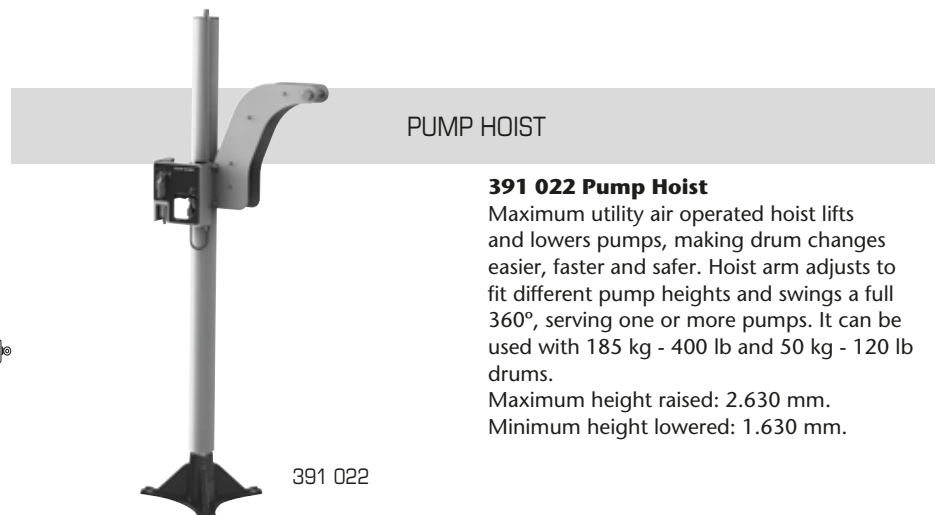

PUMP HOIST

391 022 Pump Hoist

Maximum utility air operated hoist lifts and lowers pumps, making drum changes easier, faster and safer. Hoist arm adjusts to fit different pump heights and swings a full 360°, serving one or more pumps. It can be used with 185 kg - 400 lb and 50 kg - 120 lb drums.

Maximum height raised: 2.630 mm.

Minimum height lowered: 1.630 mm.

391 022

PumpMaster 45 and PumpMaster 60 grease pumps mounted onto an air operated inductor plate for use with high viscosity, hard to pump greases directly from 185 kg drum.

When the double lip inductor plate is attached to the lower end of the pump tube, it exerts pneumatic, weight and atmospheric pressure on the material forcing pump priming. The inductor plate also serves as protection against contaminants and eliminates material waste.

The inductor system includes guide rods, drum retaining mechanism and a control box with the following features:

- On/ Off control of the pump.
- Up / Down control of the ram for easy drum exchange.
- Two independent air pressure regulators, one for the pump and the other for the power ram cylinders.
- Pump / Ram independent air pressure gauge.
- Empty drum shut-off safety feature.
- Automatic Vacuum release.

Part No. 534 421

PM45 - 40:1 pump system with air operated double post inductor for 185 kg drums. Includes pump 531 420.

Part No. 534 721

PM45 - 70:1 pump system with air operated double post inductor for 185 kg drums. Includes pump 531 720.

Part No. 534 121

PM60 - 12:1 pump system with air operated double post inductor for 185 kg drums. Includes pump 532 130.

Part No. 534 821

PM60 - 80:1 pump system with air operated double post inductor for 185 kg drums. Includes pump 532 820.

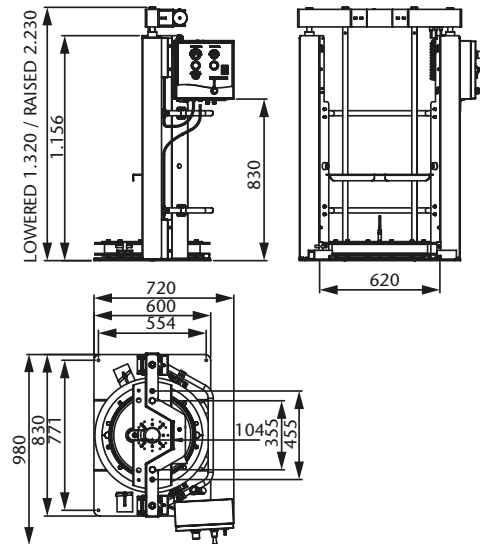

Dimensions in mm

534 811

PUMP SYSTEMS WITH PNEUMATIC PUMP HOIST AND GRAVITY INDUCTOR FOR 185 KG DRUMS

02
GREASE PUMPS



PUMPMASTER 45 and PUMPMASTER 60 grease pumps mounted onto a gravity fed follower plate and an air operated pump hoist for use with 185 kg drums.

The air operated pump hoist lifts and lowers the pump, making drums changes easier, faster and safer. The pump lower end is rigidly fixed to a follower plate with a single rubber lip. The weight of the pump, pump bracket and follower plate plus the atmospheric pressure push the assembly against the fluid eliminating channelling and air pocket, keeping lubricant free from contaminants, minimizing waste and aiding pump priming.

Part No. 534 411

PM45 - 40:1 pump system with air operated double post inductor for 185 kg drums. Includes pump 531 410 and hose connection kit Part No. 534 414.

Part No. 534 711

PM45 - 70:1 pump system with air operated double post inductor for 185 kg drums. Includes pump 531 710 and hose connection kit Part No. 534 414.

Part No. 534 811

PM60 - 80:1 pump system with air operated double post inductor for 185 kg drums. Includes pump 532 810 and hose connection kit Part No. 534 414.

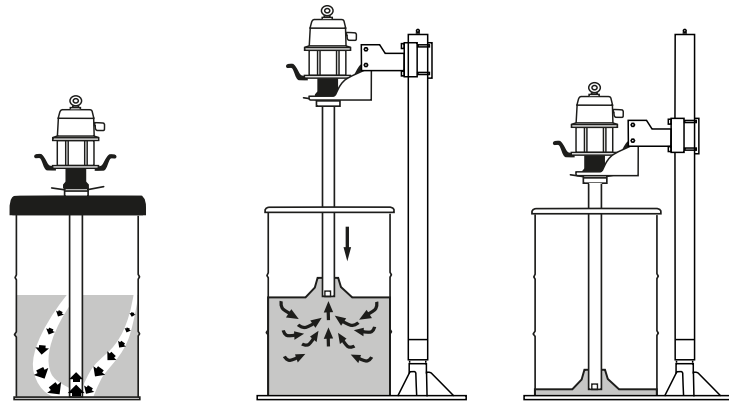

*No inductor.
Air pockets and channels
can be formed.*

*With inductor plate.
Pump is permanently primed.*

*Inductor plates aid to
minimize waste left in
the drum.*

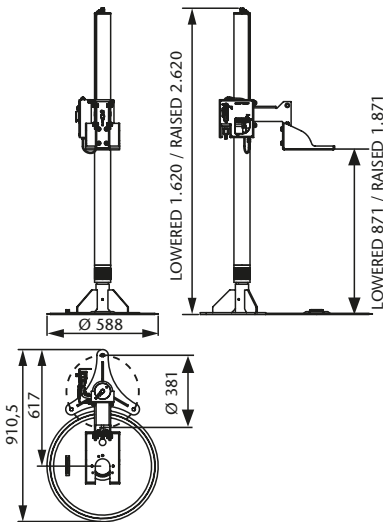

Dimensions in mm

GREASE PUMP ACCESSORIES

418 026 - 418 017



DRUM COVERS

For PumpMaster 45 and 60 pumps
Covers are made from heavy steel gauge to withstand hard usage. Cover flange provides rigidity and maintains solid position on drum. Grease pump mounts in centre of cover with four screws.

PART No.	APPLICATION	MAX. - MIN. DRUM DIAMETER
418 026	185 kg - 400 lb	620 - 580 mm
418 017	50 kg - 120 lb	395 - 350 mm

417 009 - 417 010



FOLLOWER PLATES

For PumpMaster 45 and 60 pumps
Follower plates eliminate channelling and air pockets, keep lubricant free from contaminants, remove all grease from the drum and aid pump prime.

PART No.	APPLICATION	MAX. - MIN. DRUM DIAMETER
417 009	185 kg - 400 lb	590 - 550 mm
417 010	50 kg - 120 lb	405 - 360 mm
417 011	50 kg - 120 lb	370 - 330 mm

741 604



Pump, follower plate, drum cover and drum are not included.

HOLD DOWN KITS

Allow to fix a 185 kg or a 50 kg drum to a lube truck bed when used together with drum covers 418 026 and 418 017.

741 604 Hold down kit for 185 kg - 400 lb drums
For use with drum cover 418 026.
741 605 Hold down kit for 50 kg - 129 lb drums
For use with drum cover 418 017.

AIR AND GREASE HOOK UP KITS

FOR PM3+3 PUMPS

412 920 Includes 1 m x 3/8" air hose (PN 247 710) with 3/8" - 1/2" BSP (MM) connection threads, quick air coupler 251 438, air nipple 255 338, 1,5 m x 3/8" high pressure grease hose (412 392) with 3/8"-1/2" BSP (MM) connection threads

FOR PM45 AND PM60 PUMPS⁽¹⁾

534 103 Includes 1,8 m x 1/2" air hose (248 018) with 1/2" BSP (MM) connection threads, elbow 239 352, quick air coupler 251 412, air nipple 255 312, 1,8 m x 1/2" high pressure grease hose (412 202) with 1/2" BSP (MM) connection threads and swivel elbow (945 736) with 1/2" BSP (MF) threads

(1) Hook up kits are valid for all PM45 and PM60 grease pumps except PM60 12:1 pressure ratio pump.

AIR ACCESSORIES

AIR ACCESSORIES	1/4" CONNECTION THREADS 1/4" BSP (FF)	1/2" CONNECTION THREADS 1/2" BSP (FF) WITH ONE 1/2" BSP (M) 3/8" BSP (F) ADAPTOR	3/4" CONNECTION THREADS 3/4" BSP (FF)
AIR PRESSURE REGULATOR 0-12 BAR	240 200	241 201	242 202
COMBINED AIR FILTER AND PRESSURE REGULATOR	240 500	241 501	242 302 (Filter only)
AIR LUBRICATOR	240 400	241 401	242 402



240 200



241 501



242 202

753 110 - 950 358



CAM-LOCK ADAPTORS

Allow to fix a pump horizontally or vertically to grease bags, totes and other type of containers.

753 110 Male Cam-Lock adaptor
Fixes to the bottom end of the grease pump body. Fits any standard 3" female Cam-Lock connector.

950 358 Female Cam-Lock connector
Connection thread 3" BSP (F).

LOW AND MEDIUM PRESSURE VALVES

950 305	1/4" BSP (FF), 65 bar quarter turn valve
950 320	3/8" BSP (FF), 65 bar quarter turn valve
950 300	1/2" BSP (FF), 65 bar quarter turn valve

HIGH PRESSURE VALVES

950 304	1/2" BSP (FF), 500 bar quarter turn valve
950 328	3/4" BSP (FF), 400 bar quarter turn valve
950 329	1" BSP (FF), 350 bar quarter turn valve

AIR LINE SHUTOFF VALVES

950 318	Air valve, 3/8" BSP (FF)
950 319	Air valve, 1/2" BSP (FF)

950 304



412 103

GREASE HOSES



Manufactured in NBR with a high density steel reinforcement braid. With two swaged nuts and male-male adaptors on both ends.

412 101, 1 m x 1/4". Working pressure: 400 bar. Connection threads: 1/4" BSP (MM).

412 190, 1,5 m x 1/4". Working pressure: 400 bar. Connection threads: 1/4" BSP (MM).

412 102, 2 m x 1/4". Working pressure: 400 bar. Connection threads: 1/4" BSP (MM).

412 103, 3 m x 1/4". Working pressure: 400 bar. Connection threads: 1/4" BSP (MM).

412 104, 4 m x 1/4". Working pressure: 400 bar. Connection threads: 1/4" BSP (MM).

412 391, 1,5 m x 3/8". Working pressure: 400 bar. Connection threads: 1/4" - 3/8" BSP (MM).

412 392, 1,5 m x 3/8". Working pressure: 400 bar. Connection threads: 3/8" BSP (MM).

412 202, 1,8 m x 1/2". Working pressure: 400 bar. Connection threads: 1/2" BSP (MM).

412 203, 3 m x 1/2". Working pressure: 400 bar. Connection threads: 1/2" BSP (MM).

GREASE PUMP MOUNTING ACCESSORIES QUICK REFERENCE CHART

PUMP	PUMPMaster 3+3	PUMPMaster 45	PUMPMaster 45	PUMPMaster 45	PUMPMaster 60	PUMPMaster 60
RATIO	60:1	25:1	40:1	70:1	12:1 (1)	80:1
BUNG ADAPTOR	410 002	(2)	(2)	(2)	(2)	(2)
CONNECTION HOSE KIT	412 920	534 103	534 103	534 103	539 009	534 103
DRUM COVER 185 KG	418 006	418 026	418 026	418 026	N/A	418 026
DRUM COVER 50 KG	418 004	N/A	418 017	418 017	N/A	418 017
FOLLOWER PLATE 185 KG	417 004	417 009	417 009	417 009	N/A	417 009
FOLLOWER PLATE 50 KG	417 002	N/A	417 011	417 011	N/A	417 011
CAM-LOCK ADAPTOR	N/A	N/A	753 110 ⁽³⁾	753 110 ⁽³⁾	753 110 ⁽³⁾	753 110 ⁽⁴⁾
CAM-LOCK CONNECTOR	N/A	N/A	950 358	950 358	950 358	N/A
AIR REGULATOR WITH GAUGE	241 201	241 201	241 201	241 201	241 201	241 201
AIR FILTER LUBRICATOR	241 501	241 501	241 501	241 501	241 501	241 501
FRL	241 001	241 001	241 001	241 001	241 001	241 001
AIRLINE SHUTOFF VALVE	950 318	950 319	950 319	950 319	950 319	950 319
FLUID SHUTOFF VALVE	950 304	950 328	950 304	950 304	950 328	950 304
QUICK AIR COUPLER	253 138	251 412	251 412	251 412	251 412	251 412
QUICK AIR CONNECTOR	259 038	255 312	255 312	255 312	255 312	255 312
AIR CONNECTION ACCESSORIES I.D.	3/8" - 8 mm	1/2" - 12,5 mm	1/2" - 12,5 mm	1/2" - 12,5 mm	1/2" - 12,5 mm	1/2" - 12,5 mm

(1) PM60, 12:1 pump is only available for horizontal mount on tanks, totes and grease bags.

(2) Flange mounted pumps. No bung adaptor for fixing a pump to a cover.

(3) Included in short pumps for horizontal mount on tanks, totes and grease bags. Required for vertical mount on grease tanks (long pumps).

(4) For vertical mount on grease tanks only (long pumps).

AIR OPERATED DIAPHRAGM PUMPS	48
DIAPHRAGM PUMPS ACCESSORIES	53
AIR OPERATED PISTON PUMPS FOR FLUIDS	54

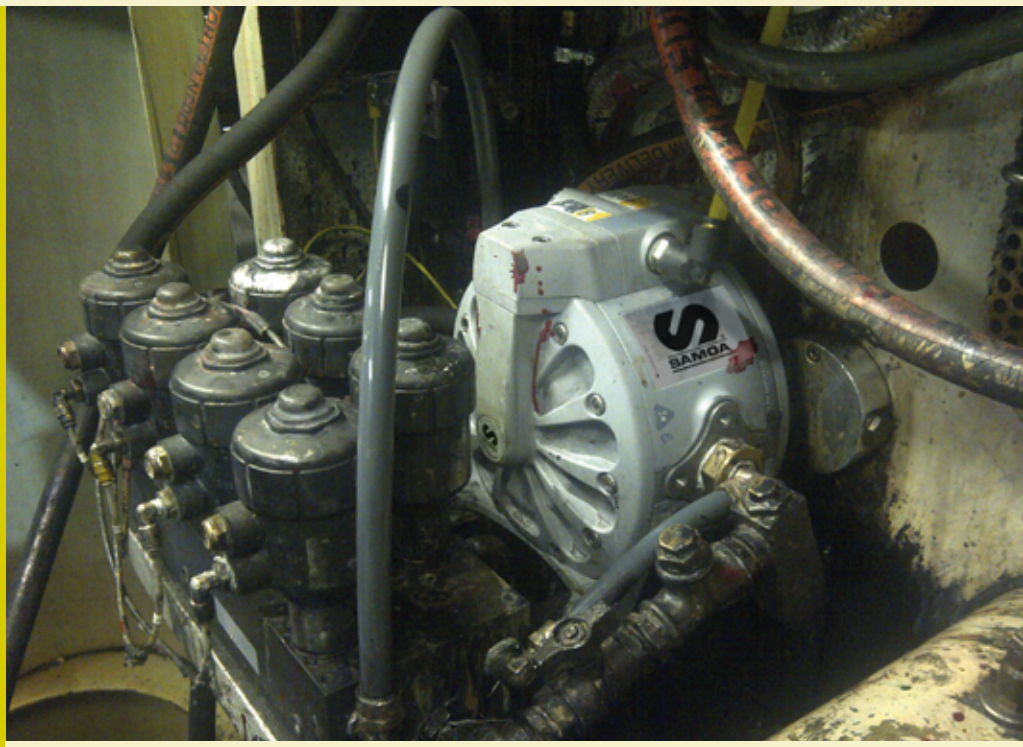

INNOVATIVE TECHNOLOGIES CREATE THE DIFFERENCE

Conventional air operated diaphragm pumps pump the fluid around the outside of the pump and compressed air acts on the inside face of the diaphragms. In Directflo® pumps the fluid is pumped through the centre of the pump and compressed air acts on the outside face of the diaphragms.

03

OTHER FLUIDS
PUMPS

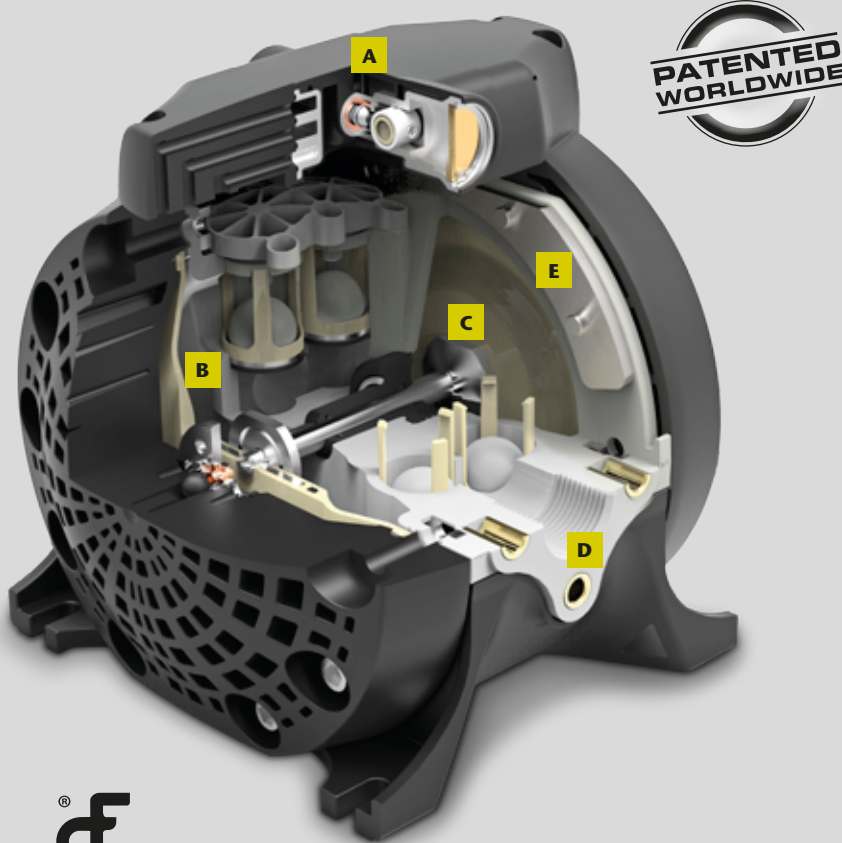

SUPERIOR ALL-ROUND PUMPING PERFORMANCE

- Significant dry suction lift eliminates self-priming issues.
- Discharge fluids at up to 8 bar (115 psi), to pump medium viscosity fluids even over long pipe runs and up to significant heights.
- Efficient compressed air usage.

- A**
FRICTIONLESS PIVOTING AIR VALVE
- High operational reliability.
 - Variable flow rate and pressure by adjusting the air pressure.
 - No stalling.
 - No icing.
 - Self-cleaning.
 - Extremely fast switching between strokes reduces air consumption and minimizes pulsations.
 - Enables a short stroke pump design, for long diaphragm life.
 - Tolerates dry, damp, dirty or oily air.

- B**
BALL CHECK VALVES ADJACENT TO DIAPHRAGMS
- Very fast valve action, even with viscous fluids. Together with the high speed frictionless pivoting air valve, this enables a short stroke pump design, for long diaphragm life.
 - Enables superior pump suction and thus improves overall pump performance.

- C**
STRESS FREE DIAPHRAGM COUPLINGS
- Nonrigid sliding couplings between push rod and diaphragms prevent diaphragm and push rod stress.
 - Long leak free diaphragm life.
 - Fast and easy diaphragm service.

- D**
SINGLE PART MOULDED PUMP BODY
- Minimizes energy losses within the pump.
 - No leaks.
 - Compact.

- E**
FLANGE FASTENING PLATES
- Pumps with plastic central bodies are fitted with load spreading stainless steel flange fastening plates.
 - Reduces the risk of damage to plastic bodies when flange bolts are over tightened.
 - Enhances sealing in the areas between flange bolts and so reduces the risk of flange leaks.

DIRECTFLO® PUMP RANGE COMPARATIVE CHART

FLUIDS HANDLED

- Oils.
- Antifreeze, coolant.
- Windshield wash.
- Hydraulic fluids.
- Diesel.

• AdBlue® / DEF.

- Water.
- Waste oil.
- Waste antifreeze.

MARKETS SERVED

- Car and truck dealers.
- Construction, mining.
- Rail way and mass transit.
- Lube trucks.
- Fleets.

• In-plant.

- Quick lubes.



PLASTIC PUMPS

DF SERIES	DF30	DF50	DF100
PUMP PRESSURE RATIO	1:1	1:1	1:1
MAXIMUM FREE DELIVERY⁽¹⁾	38 l/min (10 US gpm)	50 l/min (13.2 US gpm)	100 l/min (26.4 US gpm)
DELIVERY PER STROKE APPROX.⁽¹⁾	0,07 litres (0.02 US gal)	0,1 litres (0.026 US gal)	0,25 l (0.07 US gal)
DELIVERY PER CYCLE (2 X STROKES)⁽¹⁾	0,14 litres (0.04 US gal)	0,2 litres (0.05 US gal)	0,50 l (0.13 US gal)
AIR PRESSURE OPERATING RANGE	1,5 to 8 bar (22 to 115 psi)	1,5 to 8 bar (22 to 115 psi)	1,5 to 8 bar (22 to 115 psi)
SOLIDS IN SUSPENSION MAXIMUM SIZE	3 mm (0.12")	3 mm (1/8")	4 mm (3/16")
MAXIMUM DRY SUCTION HEAD⁽¹⁾	4 m (13')	6 m (20')	4,5 m (15')
MAXIMUM WET SUCTION HEAD⁽¹⁾	8 m (26')	8 m (26')	7 m (23')
WEIGHT	1,9 kg (4.19 lb)	2,2 kg (4.85 lb)	5,1 kg (11.24 lb)
FLUID INLET CONNECTION	1/2" BSP (F)	1/2" BSP (F)	1" BSP (F)
FLUID OUTLET CONNECTION	1/2" BSP (F)	1/2" BSP (F)	1" BSP (F)
AIR INLET CONNECTION	3/8" NPSM (F)	3/8" NPSM (F)	3/8" NPSM (F)

(1) Data measured with water, air inlet pressure 7 bar (100 psi), 20 °C (68 °F).

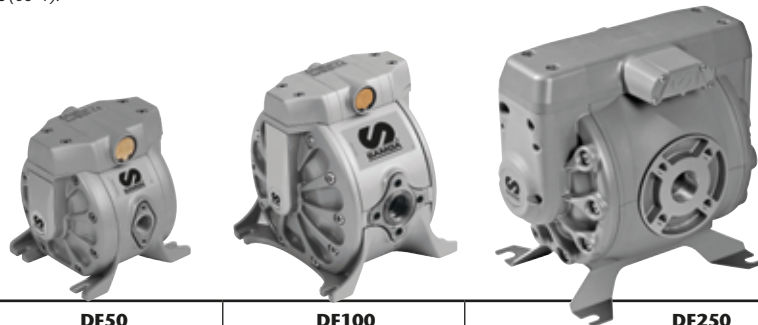

METAL PUMPS

DF SERIES	DF50	DF100	DF250
PUMP PRESSURE RATIO	1:1	1:1	1:1
MAXIMUM FREE DELIVERY⁽¹⁾	50 l/min (13.2 US gpm)	100 l/min (26.4 US gpm)	250 l/min (66 US gpm)
DELIVERY PER STROKE APPROX.⁽¹⁾	0,1 litres (0.026 US gal)	0,25 l (0.07 US gal)	0,6 l (0.16 US gal)
DELIVERY PER CYCLE (2 X STROKES)⁽¹⁾	0,2 litres (0.05 US gal)	0,5 l (0.13 US gal)	1,2 l (0.32 US gal)
AIR PRESSURE OPERATING RANGE	1,5 to 8 bar (22 to 115 psi)	1,5 to 8 bar (22 to 115 psi)	1,5 to 8 bar (22 to 115 psi)
SOLIDS IN SUSPENSION MAXIMUM SIZE	3 mm (1/8")	4 mm (3/16")	6 mm (1/4")
MAXIMUM DRY SUCTION HEAD⁽¹⁾	6 m (20')	4,5 m (15')	5 m (16.4')
MAXIMUM WET SUCTION HEAD⁽¹⁾	8 m (26')	7 m (23')	8 m (26')
WEIGHT	3,5 kg (7.72 lb)	7,2 kg (16 lb)	20 kg (45 lb)
FLUID INLET CONNECTION	1/2" BSP (F)	1" BSP (F)	1 1/2" BSP (F) and DIN PN-10 flange
FLUID OUTLET CONNECTION	1/2" BSP (F)	1" BSP (F)	1 1/2" BSP (F) and DIN PN-10 flange
AIR INLET CONNECTION	3/8" NPSM (F)	3/8" NPSM (F)	1/2" NPSM (F)

(1) Data measured with water, air inlet pressure 7 bar (100 psi), 20 °C (68 °F).

PLASTIC PUMPS



Plastic pumps are adequate for indoor use and they can handle a wide range of fluids used for vehicle service. Pump air valve module and lateral pump covers are manufactured in polypropylene or conductive polypropylene depending on models.

Typical applications are transferring and dispensing of windshield wash and antifreeze solutions, pure windshield wash and AdBlue® / DEF. They can be used as stand-alone pumps for transfer applications or as systems pumps in distribution systems that include hose reels. ATEX approved pumps are available for use in potential explosive environments and with flammable fluids like pure ethanol.

PUMP SIZE	PART NUMBER	PUMP BODY	DIAPHRAGMS	BALLS	OTHER WETTED PARTS	APPLICATIONS
DF30 (38 l/min)	553 164	Polypropylene	TPE	PTFE	FKM, Stainless steel	Antifreeze and windshield wash solutions, AdBlue® / DEF
	553 162	Conductive Polypropylene	PTFE	PTFE	FKM, Stainless steel	⊕ ATEX pump for pure ethanol, pure windshield wash
DF50 (50 l/min)	552 164	Polypropylene	TPE	PTFE	FKM, Stainless steel	Antifreeze and windshield wash solutions, AdBlue® / DEF
	552 162	Conductive Polypropylene	PTFE	PTFE	FKM, Stainless steel	⊕ ATEX pump for pure ethanol, pure windshield wash
DF100 (100 l/min)	551 164	Polypropylene	TPE	PTFE	FKM, Stainless steel	Antifreeze and windshield wash solutions, AdBlue® / DEF
	551 162	Conductive Polypropylene	PTFE	PTFE	FKM, Stainless steel	⊕ ATEX pump for pure ethanol, pure windshield wash

03 OTHER FLUIDS PUMPS

553 164

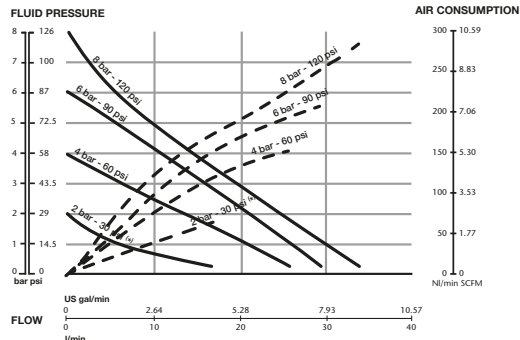

552 164

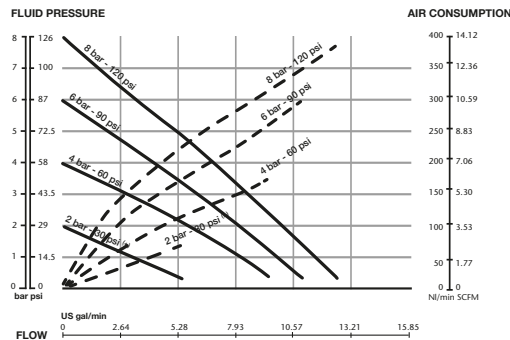

551 164

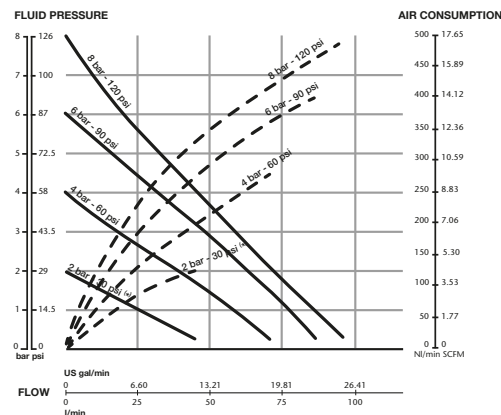



METAL PUMPS

Metal pumps are adequate for indoor and outdoor use and they can handle a wide range of fluids used for vehicle service. Pump air valve module and lateral pump covers are manufactured in aluminium.

Typical applications are transferring and dispensing of windshield wash, antifreeze solutions, lubricants and diesel, and for waste oil evacuation. They can be used as stand-alone pumps for transfer applications or as systems pumps in distribution systems that include hose reels.

PUMP SIZE	PART NUMBER	PUMP BODY	DIAPHRAGMS	BALLS	OTHER WETTED PARTS	APPLICATIONS
DF50 (50 l/min)	552 010	Aluminium	TPE	Acetal	PTFE, NBR, Stainless steel	Antifreeze and windshield wash solutions, lubricants
DF100 (100 l/min)	551 010	Aluminium	TPE	Acetal	PTFE, NBR, Stainless steel	Antifreeze and windshield wash solutions, lubricants, waste oil evacuation, diesel
	551 020	Aluminium	PTFE	Acetal	FKM, Stainless steel	Diesel (1)
DF250 (250 l/min)	554 010	Aluminium	TPE	Acetal	NBR, Stainless steel	Antifreeze and windshield wash solutions, lubricants, waste oil evacuation, diesel.
	554 020	Aluminium	PTFE	Acetal	FKM, Stainless steel	Diesel (1)

03

OTHER FLUIDS PUMPS

(1) Some types of diesel include additives in their formulation that might not be compatible with TPE. PTFE diaphragms are recommended in this case.

552 010

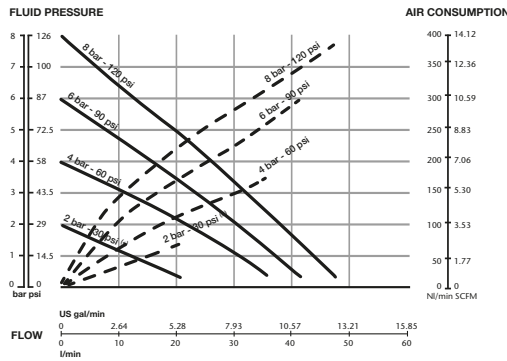

551 010

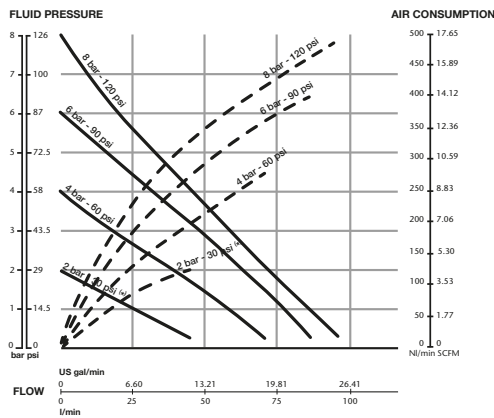

554 010

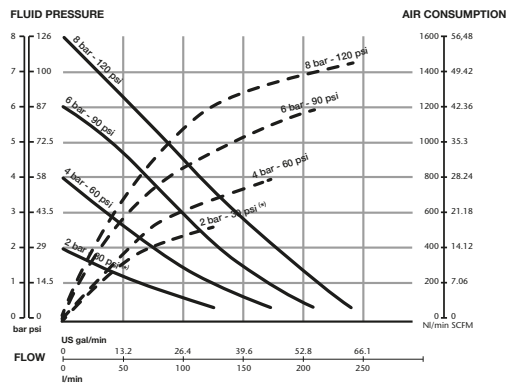

PLASTIC MIX PUMPS



DF30T and DF50T plastic diaphragm pumps with a dual inlet for 1:1 ratio mixing of fluids with similar viscosities, like windshield wash or antifreeze with water. All dual inlet pumps have 2 x 3/8" BSP (F) inlet. All other technical features of these pumps are the same as the ones for the DF30 and DF50 pumps.

PUMP SIZE	PART NUMBER	PUMP BODY	DIAPHRAGMS	BALLS	OTHER WETTED PARTS	APPLICATIONS
DF30T (38 l/min)	553 124	Polypropylene	TPE	PTFE	FKM, Stainless steel	1:1 ratio water / windshield or antifreeze solutions
DF50T (50 l/min)	552 124	Polypropylene	TPE	PTFE	FKM, Stainless steel	1:1 ratio water / windshield or antifreeze solutions

03

OTHER FLUIDS PUMPS

553 124

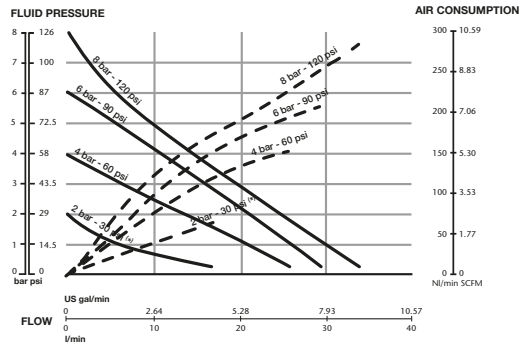

552 124

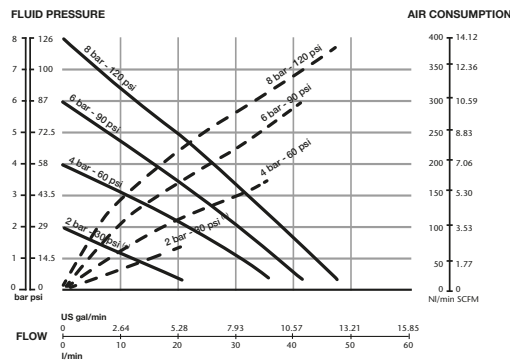

DF PUMP MOUNTING SPECIFICATIONS

DF SERIES	DF30	DF50 (1)	DF100 (1)	DF250
(A) AIR CONNECTION HOSE	3/8" - 9,5 mm	3/8" - 9,5 mm	3/8" - 9,5 mm	1/2" - 12,5 mm
(B) FLUID SUCTION HOSE	1/2" - 12,5 mm	1/2" - 12,5 mm	1" - 25 mm	1-1/2" - 38 mm
(C) FLUID DELIVERY HOSE	1/2" - 12,5 mm	1/2" - 12,5 mm	3/4" - 19 mm / 1" - 25 mm	1-1/2" - 38 mm
(D) AIR EXHAUST VENT HOSE	3/8" - 9,5 mm Requires adapter 855 432	3/8" - 9,5 mm Requires adapter 855 432	3/8" - 9,5 mm Requires adapter 855 432	1" - 25,4 mm
(E) WALL BRACKET	360 100	360 100	360 101	N/A (2)
DRUM / TOTE BRACKET	360 137	360 137	360 137	N/A
(F) AIR FILTER AND PRESSURE REGULATOR⁽³⁾	240 500	240 500	241 501	241 501
AIR PRESSURE REGULATOR⁽³⁾	240 300	240 300	241 201	241 201
QUICK AIR COUPLER	253 138	253 138	253 138	251 412
ADDITIONAL SILENCER KIT	558 338	558 338	558 338	N/A
IBC CONNECTOR	560 901	560 901	560 901	N/A

(1) Metal and plastic pumps.

(2) Pump to be floor or tank mounted.

(3) Always place the air treatment element close to the air pipe. Connect air nipple to the pump.

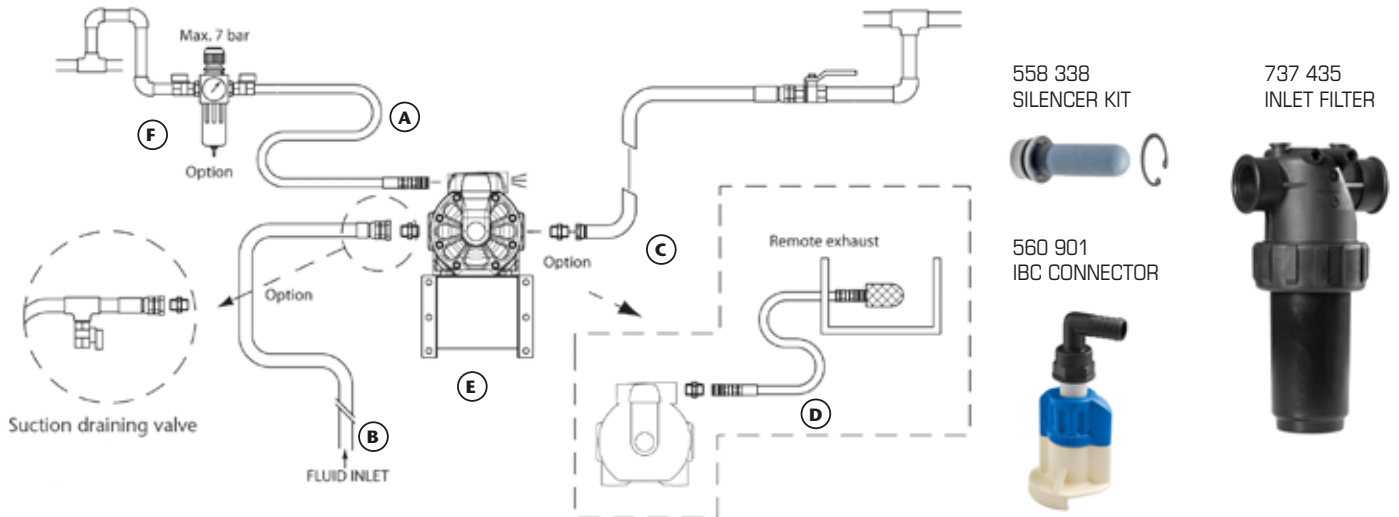

CARBON STEEL FITTINGS		POLYPROPYLENE FITTINGS		CARBON STEEL LOW PRESSURE SHUT-OFF VALVES	
945 593	1/2" BSP(MM)	689 059	1/2" BSP (MM)	950 300	1/2" BSP (FF)
945 551	3/4" BSP (MM)	689 061	1/2" BSP (F) - 3/4" BSP (F)	950 303	3/4" BSP (FF)
945 555	1" BSP (MM)	689 062	1/2" BSP (M) - 3/4" BSP (F)	950 306	1" BSP (FF)
945 567	2" - 1-1/2" BSP (MM)	689 056	3/4" BSP(F) - 1" BSP (F)	950 312	1-1/2" BSP (FF)
945 681	1-1/2" - 1" BSP (MM)	689 055	1" BSP (FF)	950 320	3/8" BSP (FF) - AIR
945 552	1" - 3/4" BSP (MM)	689 060	1" BSP (MM)	POLYPROPYLENE INLET FILTERS	
945 554	3/4" -1/2" BSP (MM)	689 079	1-1/4" BSP (M) - 3/4" BSP (F)	737 435	1-1/4" BSP (FF)
945 565	2" - 1" BSP (MF)	689 054	19 mm hose tail - 1/2" BSP (M)		
945 670	1" - 3/4" BSP (MF)	689 058	19 mm hose tail - 3/4" BSP (F) L elbow		
369 900	3/4" - 1/2" BSP (MF)	945 580	19 mm hose tail - 3/4" BSP (M)		
		689 045	19 mm hose tail - 1" (M)		
		689 072	19 mm hose tail - 1" (F)		
		689 046	25 mm hose tail - 1" (M)		
		689 073	25 mm hose tail - 1" (F)		

Use hoses and accessories compatible with the pumped fluid.



PUMP MASTER®



	PUMPMASTER 2		PUMPMASTER 4
	NICKEL PROTECTED PUMP	STAINLESS STEEL PUMP	STAINLESS STEEL PUMP
PART NO.	601 202	331 120	333 120
PUMP TYPE	Universal stub pump	Universal stub pump; divorced	Universal stub pump; divorced
PUMP PRESSURE RATIO	1:1	1:1	3:1
EFFECTIVE AIR PISTON DIAMETER	35 mm (1 1/2")	35 mm (1 1/2")	60 mm (2 1/2")
PISTON STROKE	75 mm (3")	75 mm (3")	75 mm (3")
AIR PRESSURE OPERATING RANGE	1,5 to 10 bar (20 to 145 psi)	1,5 to 10 bar (20 to 145 psi)	1,5 to 10 bar (20 to 145 psi)
AIR INLET	1/4" BSP (F)	1/4" BSP (F)	3/8" BSP (F)
FLUID INLET	1" BSP (F)	1" BSP (F)	1" BSP (F)
FLUID OUTLET	3/4" BSP (F)	3/4" BSP (F)	3/4" BSP (F)
DELIVERY AT 100 CYCLES PER MINUTE	13,5 l/min - 3.6 gal/min	25 l/min - 6.6 gal/min	25 l/min - 6.6 gal/min
MAXIMUM FREE DELIVERY	55 l/min - 14.5 gal/min	38 l/min - 10 gal/min	40 l/min - 10.6 gal/min
WETTED MATERIALS	Nickel coated aluminium and steel, stainless steel, acetal, NBR, polyurethane	PTFE, Viton®, stainless steel	PTFE, Viton®, stainless steel
HEIGHT ADJUSTABLE BUNG ADAPTOR	Included	Included	Included

Air Operated Piston Pumps for Fluids accessory:
P.N. **331 110.002**, PVC suction tube for 205 l drums.

351 121



SPECIALITY PUMP

351 121 PumpMaster 2, 1:1 pressure ratio suction pump

PumpMaster pump with 1:1 ratio with a modified air valve to allow a lower upward movement of the piston to improve pump suction capacity and avoid pump cavitation when suctioning fluids like waste oil through small diameter suction canes.

HOSE REEL MOUNTING RECOMMENDATIONS	57
RM-12 DOUBLE PEDESTAL DOUBLE ARM HOSE REELS	58
RM-12US ULTRA SLIM ENCLOSED HOSE REELS	59
RM-12S SINGLE ARM ALUMINIUM HOSE REELS	60
RM-12CL INDIVIDUALLY ENCLOSED HOSE REELS	61
RM-12L HEAVY DUTY HOSE REELS	62
RM-34 HEAVY DUTY HOSE REELS	63
RM-100 HEAVY DUTY LARGE CAPACITY HOSE REELS	64
RM-150 HEAVY DUTY LARGE DELIVERY HOSE REELS	65
COMPACT REELS FOR AIR AND CABLE	66
HOSE REEL ACCESSORIES	67





SAMOA hose reels, used around the world, are designed to be premium quality fluid reels. Hose reels are adaptable to wall, floor or ceiling mounting, individually or in banks. They are available for high, medium and low pressure applications. Different hose capacities for maximum flexibility in selecting a hose reel assembly to match any specific need. SAMOA hose reels are designed with non-restrictive fluid passages and the right hose diameter for each application to provide the quickest material delivery.

SAMOA hose reels are spring-powered and self-retracting; a latch locks the reel at desired length and a slight pull releases latch, and the hose retracts smoothly onto reel. Hose guide arm can be placed in different positions to accommodate any method of mounting and allow hose to be automatically removed or retracted without kinking, reducing strain on hose and minimizing the possibility of hose damage.

REEL MASTER®

COMPRESSED AIR • WATER • DIESEL • LUBRICANTS • ANTIFREEZE • WINDSHIELD WASH • GREASE • AdBlue®

ADVANTAGES OF THE USE OF HOSE REELS

- Increased productivity.
- Reduced wear and increased life of hoses.
- Simple hose handling and storage.
- Lower risk of accidents as hose reels keep hoses out of the floor.
- Work environment improvement.

ALL SAMOA REELS HAVE

- Superior power spring life. Special fatigue resistant steel spring guarantees long life and trouble free operation and provides even tension at every point, when pulling or retracting hose.
- Heavy duty ratchet, with large effective radial latching area for an easier and user-friendly operation.
- Metal arms, enclosures, base and spool are epoxy powder coated for increased wear resistance.
- SAMOA only uses high quality hoses, specially formulated for use in hose reels.

HOSE SPECIFICATIONS

Compressed air, low pressure water - SBR black rubber with single textile reinforcement braid and zinc plated fittings.

Oil, antifreeze solutions - NBR black rubber with single steel reinforcement steel braid and zinc plated fittings.

High pressure grease - NBR black rubber with single steel reinforcement high density braid and zinc plated fittings.

Windshield wash solutions, AdBlue®/DEF - EPDM hose with single textile reinforcement braid and stainless steel fittings.

High pressure water: SBR black rubber with single steel reinforcement braid and zinc plated fittings.

SAMOA offers a wide range of brackets, racks and stands for mounting hose reels. A properly installed hose reel has an inlet hose to prevent vibration transfer to the reel. A shut off valve is recommended at the inlet to allow the isolation of each reel for servicing.

- Install reels as high as possible when mounted to wall or ceiling. Minimum height from the lowest reel point to the floor must be 2,5 m (8').
- Always avoid lateral pulls of hose. In case they cannot be avoided, and for single reel installations, use a pivoting bracket.
- Hose reels allow positioning the hose outlet in different positions. Always choose the one that allows a tangential unwind of the hose.
- A shut off valve shall be installed at the inlet hose to allow the isolation of each reel for service purposes.

CEILING MOUNT

Use this position whenever the hose is pulled perpendicularly to the mounting surface. Typical use is when the reel is mounted to a ceiling, a hose reel stand 360 160 or 360 165, or inside lubrication pits. This position can also be used when the reel is mounted to a wall at a maximum height of 2 m. In these two cases the use of a pivoting bracket 360 111 is recommended to reduce torque when the reel is submitted to lateral pulls.

Position not valid for reels RM-100 and RM-150 because of their weight.

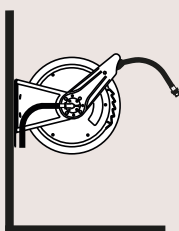
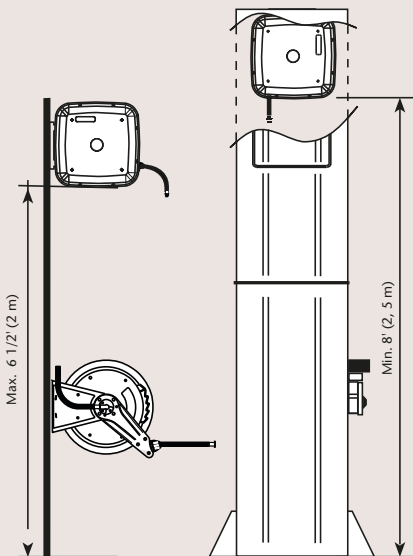
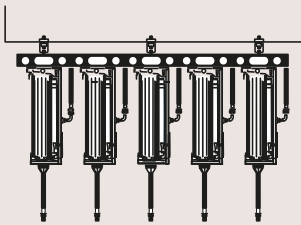

MOUNTING EXAMPLES FOR ALL RM-12 SERIES AND RM-34 REELS.

REAR ROLLER FLOOR MOUNT

Use this position whenever the hose is pulled tangentially to the mounting surface. Typical use are on lube trucks and tanks. When mounted to a wall, this position has the advantage that the hose lays close to the wall, it does not represent an obstacle and the torque on the outlet arm created when the hose is pulled laterally is minimum.

Because of their weight, RM-100 and RM-150 reels shall not be mounted to a wall.

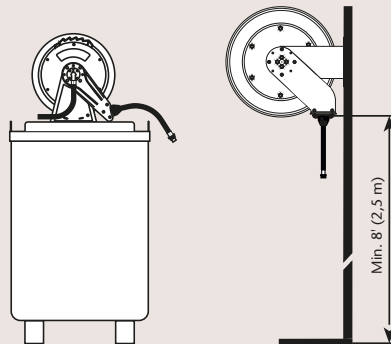

RM-12 MODEL DOES NOT ALLOW THIS POSITION.

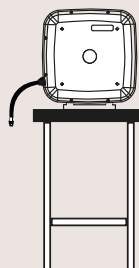
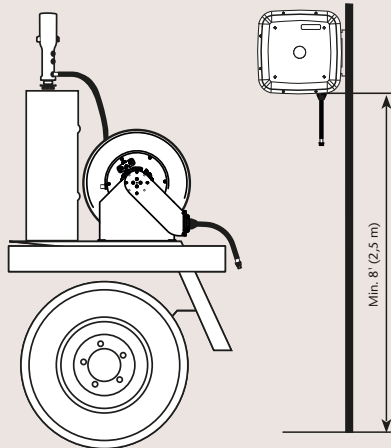

MOUNTING EXAMPLES OF ALL RM-12 SERIES, RM-34 REELS, RM-100 AND RM-150 REELS.

SIDE ROLLER MOUNT

Use this position whenever the hose is pulled parallel to the mounting surface. Typical use are on tanks, lube trucks, workbenches, etc. It can also be mounted to a wall at a minimum height of 2,5 m - 8.20', however it might create an obstacle in the shop because the hose is further out from the wall. Additionally, increased torque on the arm with lateral pulls might require using a pivoting bracket 361 111.

Because of their weight, RM-100 and RM-150 reels shall not be mounted to a wall.

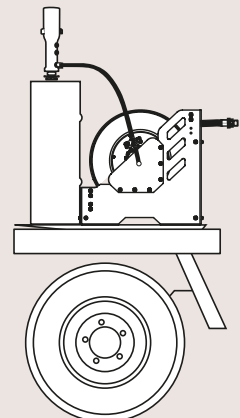
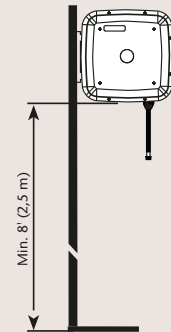
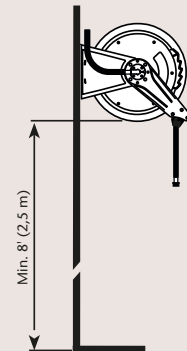

MOUNTING EXAMPLES OF ALL RM-12 SERIES, RM-34 REELS, RM-100 AND RM-150 REELS.

501 200

10 METERS MAXIMUM HOSE CAPACITY

FLUIDS HANDLED

- Air.
- Water.
- Antifreeze Solutions.
- Synthetic and Mineral Oils.
- Grease.

MARKETS / APPLICATIONS

- Car and truck dealers.
- Service shops.
- General manufacturing.
- Service stations.
- Quick lubes.

MOUNTING

- Floor.
- Wall.
- Ceiling.
- Tank.

Full metal hose reels, can handle up to 10 m x 1/2" hose.

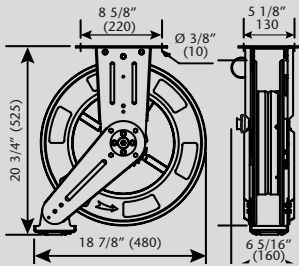

Dimensions (mm)

PART No.	BARE REEL	HOSE IN Ø	HOSE LENGTH	CONNECTING HOSE INLET	DELIVERY HOSE OUTLET	PRESSURE RATING	WEIGHT (With hose)
AIR / WATER / ANTIFREEZE SOLUTIONS							
501 100	501 198	3/8"	10 m	1/2" BSP (M)	1/4" BSPT (M)	20 bar	17,9 kg
MINERAL AND SYNTHETIC LUBRICANTS							
501 200	501 298	1/2"	10 m	1/2" BSP (M)	1/2" BSP (M)	160 bar	20 kg
GREASE							
501 300	501 398	1/4"	10 m	1/2" BSP (M)	1/4" BSP (M)	400 bar	19,2 kg

- Fatigue resistant steel spring for years of durable performance and even load when pulling and recoiling the hose.
- Full metal double pedestal arm construction, epoxy powder coated for increased wear resistance.
- Forged brass shaft ensures a leak free operation.
- Hose reels with hose include 0,8 m inlet hose.

(1) Bare reels include hose stopper and adaptors for connecting flow delivery and inlet hoses.



Reel with arms in ceiling mounting position.

502 701

15 METERS MAXIMUM HOSE CAPACITY

FLUIDS HANDLED

- Air.
- Water.
- Antifreeze Solutions.
- Synthetic and Mineral Oils.
- Grease.

MARKETS / APPLICATIONS

- Car and truck dealers.
- Service shops.

MOUNTING

- Wall.
- Ceiling.

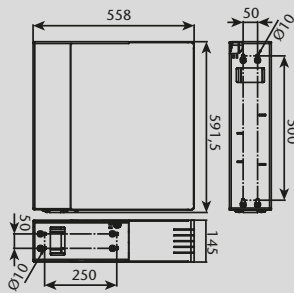

Dimensions (mm)

Full metal hose reels, can handle up to 15 m x 1/2" hose and 12 m x 5/8" hose.



PART No.	BARE REEL	HOSE IN Ø	HOSE LENGTH	CONNECTING HOSE INLET	DELIVERY HOSE OUTLET	PRESS. RATING	WEIGHT (With hose)
AIR / WATER / ANTIFREEZE SOLUTIONS							
502 711.400	502 791.400	3/8"	10 m	1/2" BSP (M)	3/8" BSP (M)	20 bar	26,5 kg
502 710.400	502 791.400	3/8"	15 m	1/2" BSP (M)	3/8" BSP (M)	20 bar	27,5 kg
MINERAL AND SYNTHETIC LUBRICANTS							
502 701.400	502 790.400	1/2"	10 m	5/8" BSP (F)	1/2" BSP (M)	100 bar	34,6 kg
502 700.400	502 790.400	1/2"	15 m	5/8" BSP (F)	1/2" BSP (M)	100 bar	32,8 kg
502 702.400	502 792.400	5/8"	12 m	5/8" BSP (F)	3/8" BSP (M)	100 bar	33,5 kg
GREASE							
502 720.400	502 793.400	3/8"	15 m	3/8" BSP (M)	1/4" BSP (M)	400 bar	30 kg

- Fully enclosed reel allows mounting a hose reel bank with no empty spaces between the reels.
- Very narrow design.
- Fatigue resistant steel spring for years of durable performance and even load when pulling and recoiling the hose.
- Full metal reel, epoxy powder coated for increased wear resistance.
- Full port shaft and swivel for no restrictions.
- Spool mounted on two permanent lubricated and sealed ball bearings to reduce torque load on spring for smooth retraction and longer life.
- Hose reel with hose include 0,8 m inlet hose.

506 202

15 METERS MAXIMUM HOSE CAPACITY

FLUIDS HANDLED

- Air.
- Water.
- Antifreeze and Windshield Wash Solutions.
- High Pressure Hot Water.
- Synthetic and Mineral Oils.
- AdBlue® / DEF.
- Grease.

MARKETS / APPLICATIONS

- Car and truck dealers.
- Service shops.
- Fleets.
- General manufacturing.
- Service stations.
- Lube trucks.
- Quick lubes.

MOUNTING

- Floor.
- Wall.
- Ceiling.
- Tank.

Aluminium base and arms with composite spool hose reels, can handle up to 15 m x 1/2" hose.

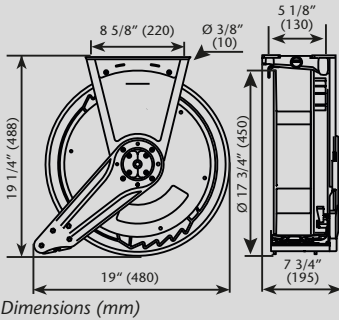

- Aluminium base and guide arm provide the rigidity to withstand the most demanding applications while offering a reduced weight for easy installation.
- Fatigue resistant steel spring for years of durable performance and even load when pulling and recoiling the hose.
- Full port shaft and swivel for no restrictions.
- Spool mounted on two permanent lubricated and sealed ball bearings to reduce torque load on spring for smooth retraction and longer life.
- Large effective radial latching area for easier operation.
- Six roller guide outlet prevents hose pinching and reduces friction.
- Hose guide arm can be placed in different positions to accommodate any method of mounting.
- Hose reels with hose include 0,8 m inlet hose.

PART No.	BARE REEL	HOSE IN Ø	HOSE LENGTH	CONNECTING HOSE INLET	DELIVERY HOSE OUTLET	PRESSURE RATING	WEIGHT (With hose)
AIR / WATER / ANTIFREEZE SOLUTIONS							
506 101	506 920.001	3/8"	10 m	3/8" BSP (M)	3/8" BSP (M)	20 bar	12,1 kg
506 121	506 922.001	3/8"	15 m	3/8" BSP (M)	3/8" BSP (M)	20 bar	14,2 kg
506 122	506 921.001	1/2"	15 m	1/2" BSP (M)	1/2" BSP (M)	20 bar	14,9 kg
WINDSHIELD AND WINDSHIELD WASH SOLUTIONS / AdBlue® - DEF / DETERGENTS							
506 762	506 976	1/2"	10 m	1/2" BSP (M)	1/2" BSP (M)	20 bar	13 kg
506 782	506 978	1/2"	15 m	1/2" BSP (M)	1/2" BSP (M)	20 bar	15,5 kg
SYNTHETIC AND MINERAL OILS							
506 202	506 920	1/2"	10 m	1/2" BSP (M)	1/2" BSP (M)	160 bar	12,6 kg
506 222	506 922	1/2"	15 m	1/2" BSP (M)	1/2" BSP (M)	160 bar	14,9 kg
506 212*	506 921	1/2"	15 + 3 m	1/2" BSP (M)	1/2" BSP (M)	160 bar	15,7 kg
WASTE OIL SUCTION							
506 503	506 950	5/8"	6 m	1/2" BSP (M)	1/2" BSP (M)	Vacuum	13,3 kg
GREASE AND HYDRAULIC FLUID							
506 300	506 930	1/4"	10 m	1/4" BSP (M)	1/4" BSP (M)	400 bar	12,4 kg
506 301	506 934	3/8"	10 m	3/8" BSP (M)	1/4" BSP (M)	400 bar	12,9 kg
506 321	506 936	3/8"	15 m	3/8" BSP (M)	1/4" BSP (M)	400 bar	16 kg
506 311*	506 935	3/8"	15 + 3 m	3/8" BSP (M)	1/4" BSP (M)	400 bar	17 kg
HIGH PRESSURE HOT WATER (UP TO 100 °C)							
506 421	506 942	3/8"	15 m	3/8" BSP (M)	1/4" BSP (M)	170 bar	15,1 kg



Reel with arms in ceiling mounting position.

*15 + 3 m models shall be need in installations allowing a minimum of 3 m of hose hanging from the reel.

507 202

15 METERS MAXIMUM HOSE CAPACITY

FLUIDS HANDLED

- Air.
- Water.
- Antifreeze and Windshield Wash Solutions.
- High Pressure Hot Water.
- Synthetic and Mineral Oils.
- AdBlue® / DEF.
- Grease.

MARKETS / APPLICATIONS

- Car and truck dealers.
- Service shops.
- Fleets.
- General manufacturing.
- Service stations.
- Lube trucks.
- Quick lubes.

MOUNTING

- Floor.
- Wall.
- Ceiling.
- Tank.

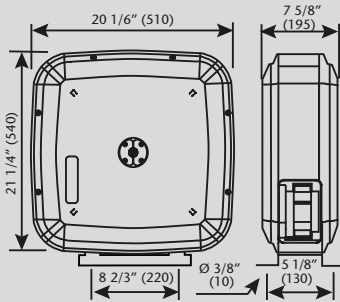

Dimensions (mm)

Aluminium enclosure with composite spool hose reels, can handle up to 15 m x 1/2" hose.



04

HOSE REELS

PART No.	BARE REEL	HOSE IN Ø	HOSE LENGTH	CONNECTING HOSE INLET	DELIVERY HOSE OUTLET	PRESSURE RATING	WEIGHT (With hose)
AIR / WATER / ANTIFREEZE SOLUTIONS							
507 101	507 920.001	3/8"	10 m	3/8" BSP (M)	3/8" BSP (M)	20 bar	18,4 kg
507 121	507 922.001	3/8"	15 m	3/8" BSP (M)	3/8" BSP (M)	20 bar	20,7 kg
507122	507 921.001	1/2"	15 m	1/2" BSP (M)	1/2" BSP (M)	20 bar	21,4 kg
WINDSHIELD AND WINDSHIELD WASH SOLUTIONS / AdBlue® - DEF / DETERGENTS							
507 762	507 976	1/2"	10 m	1/2" BSP (M)	1/2" BSP (M)	20 bar	19 kg
507 782	507 978	1/2"	15 m	1/2" BSP (M)	1/2" BSP (M)	20 bar	20,5 kg
SYNTHETIC AND MINERAL OILS							
507 202	507 920	1/2"	10 m	1/2" BSP (M)	1/2" BSP (M)	160 bar	18,9 kg
507 222	507 922	1/2"	15 m	1/2" BSP (M)	1/2" BSP (M)	160 bar	21,4 kg
507 212*	507 921	1/2"	15 + 3 m	1/2" BSP (M)	1/2" BSP (M)	160 bar	22,2 kg
WASTE OIL SUCTION							
507 503	507 950	5/8"	6 m	1/2" BSP (M)	1/2" BSP (M)	Vacuum	19,1 kg
GREASE AND HYDRAULIC FLUID							
507 300	507 930	1/4"	10 m	1/4" BSP (M)	1/4" BSP (M)	400 bar	18,8 kg
507 301	507 934	3/8"	10 m	3/8" BSP (M)	1/4" BSP (M)	400 bar	19,5 kg
507 321	507 936	3/8"	15 m	3/8" BSP (M)	1/4" BSP (M)	400 bar	22,6 kg
507 311*	507 935	3/8"	15 + 3 m	3/8" BSP (M)	1/4" BSP (M)	400 bar	23,6 kg
HIGH PRESSURE HOT WATER (UP TO 100 °C)							
507 421	507 942	3/8"	15 m	3/8" BSP (M)	1/4" BSP (M)	170 bar	22,2 kg

- Corrosion resistant aluminium enclosure form a very rigid and stable structure, with light weight and attractive design.
- Fatigue resistant steel spring for years of durable performance and even load when pulling and recoiling the hose.
- Full port shaft and swivel for no restrictions.
- Spool mounted on two permanent lubricated and sealed ball bearings to reduce torque load on spring for smooth retraction and longer life.
- Large effective radial latching area for easier operation.
- Positionable mounting brackets to accommodate any method of mounting.
- Two large lateral service windows facilitate common maintenance operations.
- Hose reels with hose include 0,8 m inlet hose.



Reel with arms in ceiling mounting position.

*15 + 3 m models shall be need in installations allowing a minimum of 3 m of hose hanging from the reel.

504 250

15 METERS MAXIMUM HOSE CAPACITY

FLUIDS HANDLED

- Air.
- Water.
- Antifreeze and Windshield Wash Solutions.
- High Pressure Hot Water.
- Synthetic and Mineral Oils.
- Grease.

MARKETS / APPLICATIONS

- Car and truck dealers.
- Service shops.
- Fleets.
- Lube trucks.
- Mining and construction.
- Railroad and mass transit.
- General manufacturing.

MOUNTING

- Floor.
- Wall.
- Ceiling.
- Tank.

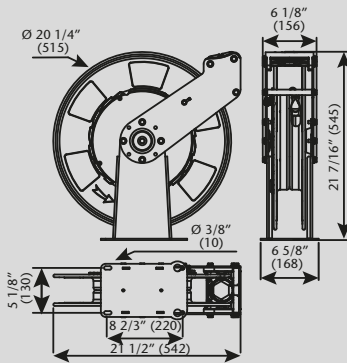

Dimensions (mm)

Full metal Intensive Duty double pedestal hose reels, with hose capacity up to 15 m x 1/2" hose.



- Very tough construction able to stand regular use and abuse in Intensive Duty applications.
- Fatigue resistant steel spring for years of durable performance and even load when pulling and recoiling the hose.
- Full port shaft and swivel for no restrictions.
- Spool mounted on two permanent lubricated and sealed ball bearings to reduce torque load on spring for smooth retraction and longer life.
- Large effective radial latching area for easier operation.
- Hose guide arm can be placed in different positions to accommodate any method of mounting.
- Narrow footprint allows accommodating more reels on the same surface.
- Hose reels with hose include 0,8 m inlet hose.

PART No.	BARE REEL	HOSE IN Ø	HOSE LENGTH	CONNECTING HOSE INLET	DELIVERY HOSE OUTLET	PRESSURE RATING	WEIGHT (With hose)
AIR / WATER / ANTIFREEZE SOLUTIONS							
504 150	504 159	1/2"	15 m	1/2" BSP (M)	1/2" BSP (M)	20 bar	24 kg
SYNTHETIC AND MINERAL OILS							
504 250	504 259	1/2"	15 m	1/2" BSP (M)	1/2" BSP (M)	160 bar	24 kg
GREASE AND HYDRAULIC FLUID							
504 350	504 359.001	1/4"	15 m	1/4" BSP (M)	1/4" BSP (M)	400 bar	27,5 kg
504 351	504 359	3/8"	15 m	3/8" BSP (M)	1/4" BSP (M)	400 bar	26 kg
HIGH PRESSURE HOT WATER (UP TO 100 °C)							
504 450	504 459	3/8"	15 m	3/8" BSP (M)	1/4" BSP (M)	170 bar	26 kg



Reel with arms in ceiling mounting position.

FLUIDS HANDLED

- Air.
- Water.
- Antifreeze and windshield wash solutions.
- Synthetic and mineral oils.
- AdBlue® / DEF.
- Waste Oil Evacuation.
- Diesel.
- Grease.

MARKETS / APPLICATIONS

- Truck dealers.
- Service shops.
- Fleets.
- Lube trucks.
- Mining and construction.
- Railroad and mass transit.
- General manufacturing.

MOUNTING

- Floor.
- Wall.
- Ceiling.
- Tank.

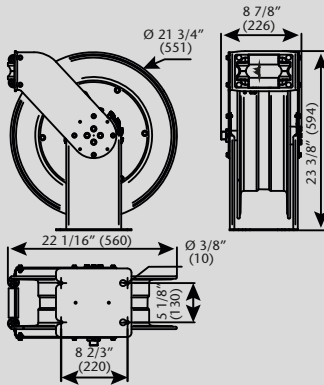

Dimensions (mm)

Full metal, Intensive Duty double pedestal hose reels with hose capacity up to 15 m x 3/4" and 20 m x 1/2" hose.



PART No.	BARE REEL	HOSE IN Ø	HOSE LENGTH	CONNECTING HOSE INLET	DELIVERY HOSE OUTLET	PRESSURE RATING	WEIGHT (With hose)
AIR / WATER / ANTIFREEZE SOLUTIONS / DIESEL / LUBRICANTS							
505 232	505 932	1/2"	20 m	3/4" BSP (F)	1/2" BSP (M)	160 bar	36 kg
505 224	505 924	3/4"	15 m	3/4" BSP (M)	3/4" BSP (M)	125 bar	38 kg
ADBLUE® - DEF / WINDSHIELD WASH SOLUTIONS / WASHING SOLUTIONS							
505 524	505 529	3/4"	15 m	3/4" BSP (M)	3/4" BSP (M)	20 bar	39 kg
GREASE AND HYDRAULIC FLUID							
505 332	505 339	1/2"	20 m	1/2" BSP (M)	1/2" BSP (M)	400 bar	39 kg

- Very tough construction able to stand regular use and abuse in Intensive Duty applications.
- Fatigue resistant steel spring for years of durable performance and even load when pulling and recoiling the hose.
- Full port shaft and swivel for no restrictions.
- Spool mounted on two permanent lubricated and sealed ball bearings to reduce torque load on spring for smooth retraction and longer life.
- Large effective radial latching area for easier operation.
- Hose guide arm can be placed in different positions to accommodate any method of mounting.
- Narrow footprint allows accommodating more reels on the same surface.
- Hose reels with hose include 0,8 m inlet hose.

506 202

15, 20, 25 AND 30 METERS MAXIMUM HOSE CAPACITY

FLUIDS HANDLED

- Air.
- Water.
- Antifreeze solutions.
- Synthetic and mineral oils.
- Waste Oil Evacuation.
- Diesel.

MARKETS / APPLICATIONS

- Fleets.
- Lube trucks.
- Mining and construction.
- Railroad and mass transit.
- General manufacturing.

MOUNTING

- Floor.
- Tank.

Full metal, Intensive Duty, double pedestal hose reels, with hose capacity up to 15 m x 1", 20 m or 25 m x 3/4" hose and 30 m x 1/2" hose.

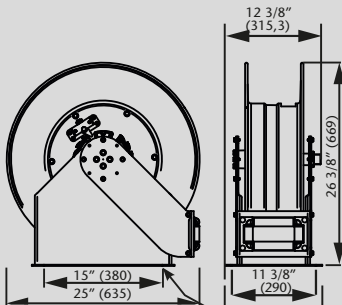

Dimensions (mm)

PART No.	BARE REEL	HOSE IN Ø	HOSE LENGTH	CONNECTING HOSE INLET	DELIVERY HOSE OUTLET	PRESSURE RATING	WEIGHT (With hose)
AIR / WATER / ANTIFREEZE SOLUTIONS / DIESEL							
508 125	508 925	1"	15 m	1" BSP (F)	1" BSP (F)	25 bar	50 kg
LUBRICANTS / WASTE OIL EVACUATION							
508 225	508 925	1"	15 m	1" BSP (F)	1" BSP (F)	90 bar	56 kg
508 234	508 924	3/4"	20 m	1" BSP (F)	3/4" BSP (F)	100 bar	55 kg
508 244	508 944	3/4"	25 m	1" BSP (F)	3/4" BSP (F)	100 bar	57 kg
508 252	508 942	1/2"	30 m	1" BSP (F)	1/2" BSP (F)	160 bar	55 kg

- Very tough construction large capacity reels, able to stand regular use and abuse in Intensive Duty applications.
- Fatigue resistant steel spring for years of durable performance and even load when pulling and recoiling the hose.
- Full port shaft and swivel for no restrictions.
- Spool mounted on two permanent lubricated and sealed ball bearings to reduce torque load on spring for smooth retraction and longer life.
- Large effective radial latching area for easier operation.
- Hose guide arm can be placed in different positions to accommodate any method of mounting.
- Narrow footprint allows accommodating more reels on the same surface.
- Hose reels with hose include 0,8 m inlet hose.

508 810

15 METERS MAXIMUM HOSE CAPACITY

FLUIDS HANDLED

- Water.
- Diesel.

MARKETS / APPLICATIONS

- Fleets.
- Lube trucks.
- Mining and construction.
- Railroad and mass transit.
- General manufacturing.

MOUNTING

- Floor.
- Tank.

Full metal, Intensive Duty, hose reel with hose capacity up to 15 m x 1-1/2" hose.

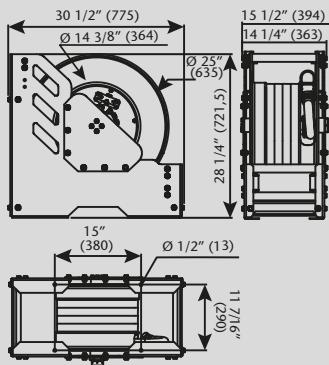

Dimensions (mm)

PART No.	BARE REEL	HOSE IN Ø	HOSE LENGTH	CONNECTING HOSE INLET	DELIVERY HOSE OUTLET	PRESSURE RATING	WEIGHT (With hose)
WATER / DIESEL							
508 810	508 890	1-1/2"	15 m	1-1/2" BSP (F)	1-1/2" BSP (F)	20 bar	87 kg

- Very tough construction large delivery reels, able to stand regular use and abuse in Intensive Duty applications.
- Fatigue resistant steel spring for years of durable performance and even load when pulling and recoiling the hose.
- Full port shaft and swivel for no restrictions.
- Spool mounted on two permanent lubricated and sealed ball bearings to reduce torque load on spring for smooth retraction and longer life.
- Large effective radial latching area for easier operation.
- Hose guide arm can be placed in two different positions to accommodate any method of mounting.
- Narrow footprint allows accommodating more reels on the same surface.

500 115

COMPACT REELS FOR AIR - RM-38 SERIES

Compact enclosed reels for compressed air, manufactured in steel. All reels include pivoting wall bracket for an easy and convenient installation. Reels are supplied with PVC hose and they have a maximum working pressure of 15 bar (285 psi).

500 115 Compact hose reel for air 15 m x 8 mm hose

Compact reel for air with 15 m x 8 mm hose. Includes 0.8 m inlet hose and pivoting bracket. Inlet thread: 3/8" BSP (M). Outlet thread: 1/4" BSP (M).

500 116 Compact hose reel for air 12 m x 10 mm hose

Compact reel for air with 12 m x 10 mm hose. Includes 0.8 m inlet hose and pivoting bracket. Inlet thread: 3/8" BSP (M). Outlet thread: 3/8" BSP (M).

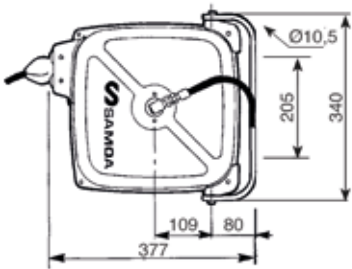

04

HOSE REELS

612 400 - 612 100

CABLE REELS - RM-POWER SERIES

Compact reels with high resistance thermoplastic enclosure. Compact design, with wide outlet for a comfortable and friction free cable extension. All reels include pivoting bracket, cable specified for each model, and cable overload breaker.

For use with 230 V – 50 Hz only.



612 400 - 230 V, 50 Hz cable reel with 230 V AC to 24 V DC transformer with LED lamp.

15 m H05RN-F 2x1 mm² cable hose reel. Includes a 230 V AC to 24 V DC transformer and a 900 LUMEN LED light.

612 100 - 230 V, 50 Hz cable reel

Includes 15 m H05VV-F 3x1,5 mm² cable, 230 V - 50 Hz. Maximum power: 800 W with the cable coiled and 2.000 W with the cable fully extended because of heat dissipation.

612 200 - 230 V, 50 Hz cable reel with 230 V AC to 24 V DC transformer

Includes 15 m H05VV-F 2x1 mm² cable. Maximum power: 60 W Includes a 230 V AC to 24 V DC transformer. For use with an E27 24 V - DC lamp (lamp not included).

612 300 - 230 V, 50 Hz cable reel with 230 V AC to 12 V DC transformer

Includes 15 m H05VV-F 2x1 mm² cable. Maximum power: 60 W Includes a 230 V AC to 12 V DC transformer. For use with an E27 12 V - DC lamp (inspection lamp included, bulb not included).

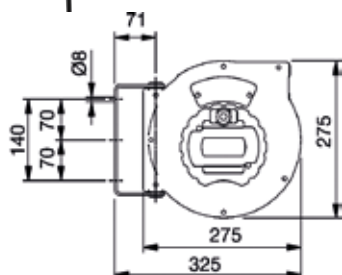

360 111 - 360 119



SINGLE REEL BRACKETS

For use with all RM12 and RM34 hose reels.

360 111 Pivoting wall bracket

360 119 Single reel bracket.

360 113 One reel bracket for

432 814 trolley

Not for RM34 hose reels.

360 135 One reel bracket for

432 000 trolley

Not for RM34 hose reels.

360 117



MULTIPLE REELS BRACKET

For use with all RM12 hose reels.

360 114, 2 hose reel bracket

Dimensions: 550 x 308 x 75 mm.

360 115, 3 hose reel bracket

Dimensions 825 x 308 x 75 mm.

360 117, 5 hose reel bracket

Dimensions 1.375 x 308 x 75 mm.

360 118 Bracket for I beams

Allow fixing a multiple reel bracket

to an "I" beam (100/175 mm)

without drilling. Two are required

for the two and three reel bracket

and three for the five reel bracket.

360 122



DRIP POCKETS

360 122 Drip pocket

360 127 Drip pocket and gun holder

360 127



360 161



TWO HOSE REEL STAND

360 161 Two hose reel stand

For use with any pair of RM12 hose reels. Height: 2.375 mm.

360 162



THREE HOSE REEL STAND

360 162 Three hose reel stand

For use with all RM12 models, includes drip tray. Dimensions: 1.200 x 400 x 2.220 mm.

360 163



FIVE HOSE REEL STAND

360 163 Five hose reel stand

For use with all RM12 models, includes drip tray. Dimensions: 1.750 x 400 x 2.220 mm.

360 160



SIX HOSE REEL STAND

Very solid construction, allows mounting six RM-12 or RM-34 hose reels depending on models. Two extra reels can be mounted using the optional accessory. Six reel stands include perforated internal side panels and drip tray.

360 160 Six reel stand

Narrow model for use with RM-12 reels. Dimensions: 1.543 x 760 x 2.600 mm.

360 165 Six reel stand

Wide model for use with RM12C and RM34 reels. Dimensions: 1.972 x 760 x 2.600 mm.

04

HOSE REELS

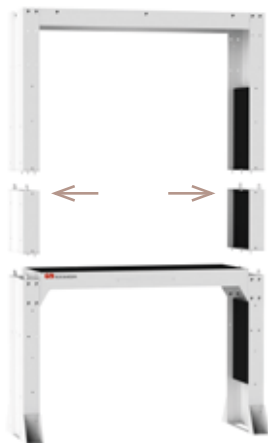

360 164

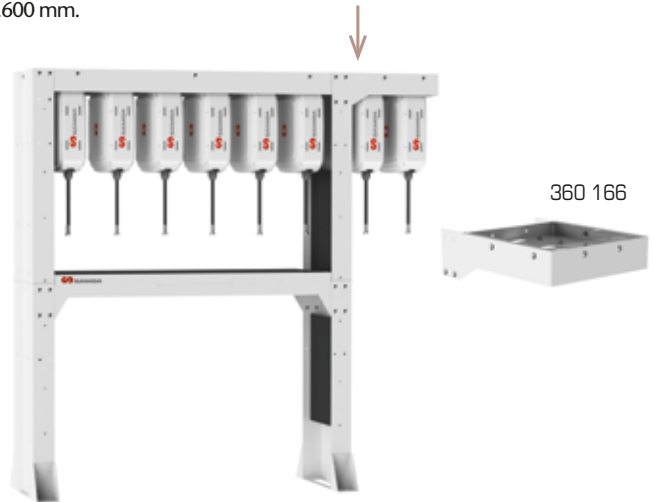

360 166

SIX HOSE REEL STANDS ACCESSORIES

For use with 360 160 and 360 165 stands as mentioned.

360 164 Height extension kit

The kit allows rising 500 mm the stand height. For use with 360 160 and 360 165 stands.

360 166 Additional bracket for two hose reel

The additional bracket allows mounting two additional hose reels on one side of a six reel stand 360 160 and 360 165.

360 168 Additional drip tray

For use on one side of a six reel stand 360 160 and 360 165 when equipped with the 360 166 additional bracket.

736 229 Drawers kit

The kit allows mounting two drawers with lock to the six reel stand 360 160.

CONTROL VALVES FOR DISPENSING OIL AND OTHER FLUIDS	70
ELECTRONIC METERED CONTROL VALVES FOR DISPENSING OIL AND OTHER FLUIDS	72
MECHANICAL METERED CONTROL VALVES FOR DISPENSING OIL AND OTHER FLUIDS	74
MECHANICAL METERED PRESET CONTROL VALVES FOR DISPENSING OIL AND OTHER FLUIDS	75
IN-LINE METERS	76
PULSE TRANSMITTERS	77
OTHER METERS AND ACCESSORIES	78
GREASE GUNS AND ACCESSORIES	79
OIL BARS, SPIGOT VALVES AND OTHER FLUID DISPENSE GUNS	80



363 115

PA40 - OIL CONTROL VALVE, 40 L/MIN

SAMOA control valves are used at end of hose assembly to dispense lubricants and antifreeze solutions.

FLUIDS HANDLED

- Synthetic and mineral based lubricants.
- Gear Oil.
- Hydraulic oil and fluids.
- ATF.
- Antifreeze solutions.

MARKETS SERVED

- Car and truck dealerships.
- Fast lube and maintenance shops.
- Fleet service.
- Mining and construction.
- Lube trucks.

DURABILITY AND PERFORMANCE

- Extensively and rigorously field tested. Reliable performance.
- Aluminium body with light weight ergonomic design. Soft grip valve for comfort.
- Cam and piston valve design for minimum flow resistance.
- Large inlet swivel and inlet filter.
- Swivel and outlet covers.
- Safety latch must be depressed before product can be dispensed. Trigger can be locked open for dispensing large volumes.
- Wide selection of outlets available.



TECHNICAL DATA

Maximum flow rate	40 l/min (11 gal/min)
Maximum working pressure	100 bar (1,450 psi)
Operating temperature range	-10 °C to 70 °C (14 to 160 °F)
Fluid inlet	1/2" BSP (F)
Fluid outlet	1/2" BSP (F)
Wetted parts	Aluminium / Zinc plated steel / TPU / Polyamide
Fluid compatibility	Lubricants, ATF, antifreeze (Glycol) and antifreeze water solutions
Weight	470 g (1 lb)

ORDERING INFORMATION

PART No.	OUTLET NOZZLE TYPE	INCLUDED OUTLET PART No.	
363 100	No outlet	-	
363 116	60° rigid outlet and quarter turn non drip tip	369 232	(A)
363 115	Flexible outlet with 90° tube and automatic non-drip tip	369 230	(B)
363 114	Flexible outlet with 90° tube and quarter turn non-drip tip	369 228	(C)
363 112	Flexible outlet and automatic non-drip tip	369 224	(D)
363 117	Formable outlet and quarter turn non-drip	369 234	(E)
363 118	Formable outlet and quarter turn narrow non-drip (Ø 8 mm)	369 241	(F)

Non drip tips are manufactured in brass.

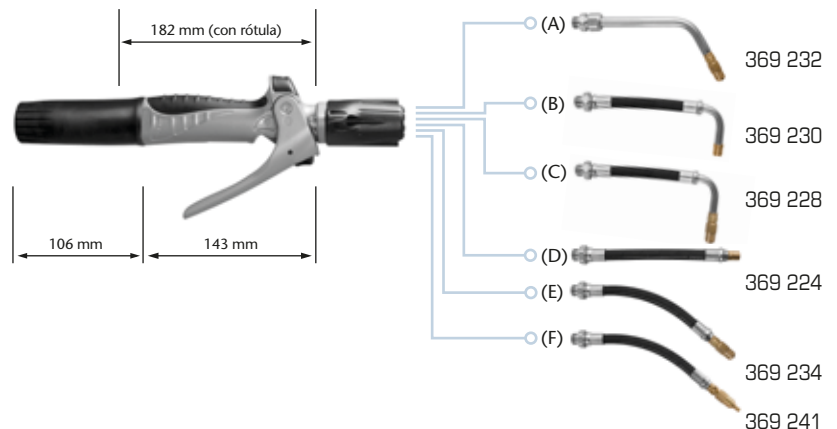

REGISTERED DESIGN

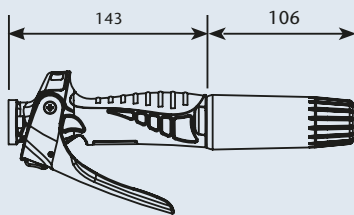

Dimensions (mm)

Closed

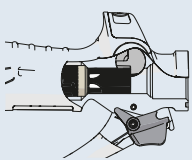

Safety

Open

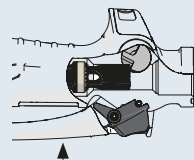

Easy-release

Locked

The new cam actuated piston-valve is designed for unrestricted flow and superb control. It incorporates an ergonomic trigger with safety, locking and easy-release functions.

363 053

PA70 - HIGH FLOW OIL CONTROL VALVE, 70 L/MIN



SAMOA large delivery control valves are used at end of hose assembly to dispense large volumes of lubricants and antifreeze solutions.

FLUIDS HANDLED

- Synthetic and mineral based lubricants.
- Gear Oil.
- Hydraulic oil and fluids.
- ATF.
- Antifreeze solutions.

MARKETS SERVED

- Truck dealerships.
- Fleet service.
- Mining and construction.
- Lube trucks.
- Railroad and mass transit vehicles.

DURABLE AND HIGH FLOW PERFORMANCE

- Extensively and rigorously field tested. Reliable performance.
- Heavy Duty aluminium pressure cast body to stand the toughest working conditions.
- High flow pressure balanced valve for comfortable use.
- Large port inlet swivel (1" and 3/4"). Inlet filter with large screen surface.
- Safety guard avoids accidental openings.
- Trigger can be blocked open for dispensing large volumes.
- Outlets have 3/4" BSP (M) connection thread and use a bonded seal washer to assure a leak free operation.

TECHNICAL DATA

Maximum flow rate	90 l/min (24 gal/min)
Maximum working pressure	100 bar (1,450 psi)
Operating temperature range	-10 °C to 70 °C (14 to 160 °F)
Fluid inlet	3/4" BSP (F) or 1" BSP (F)
Fluid outlet	3/4" BSP (F)
Wetted parts	Aluminium / Zinc plated steel and brass / NBR
Fluid compatibility	All type of synthetic and mineral oils, antifreeze solutions, hydraulic fluid
Weight	2,05 kg (4.5 lb)

ORDERING INFORMATION

PART No.	OUTLET NOZZLE TYPE	INLET SWIVEL THREAD	
363 053	30° rigid with semiautomatic non-drip tip	3/4" BSP (F)	(A)
363 054	Flexible outlet with semiautomatic non-drip tip	3/4" BSP (F)	(B)
363 055	30° rigid with semiautomatic non drip tip	1" BSP (F)	(A)
363 056	Flexible outlet with semiautomatic non drip tip	1" BSP (F)	(B)

REGISTERED DESIGN

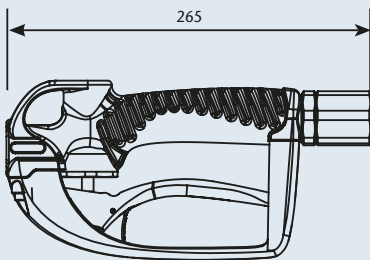

Dimensions (mm)

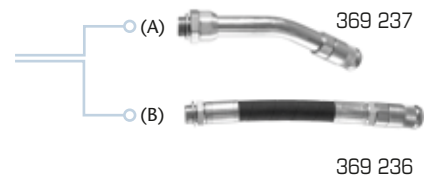
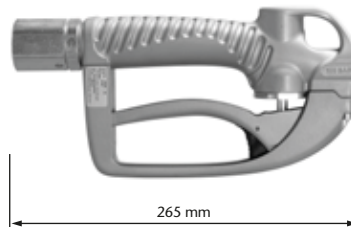

Closed

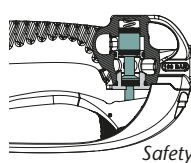

Open

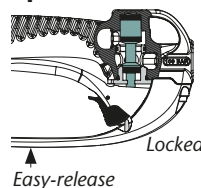

The new pressure balanced spool valve is designed for unrestricted flow, superb control and comfortable use. The control valve incorporates hand-guard for safety and an ergonomic trigger with locking function.

ELECTRONIC METERED CONTROL VALVES FOR DISPENSING OIL AND OTHER FLUIDS

365 534

EC30 - OVAL GEAR WITH DIGITAL DISPLAY HAND HELD METER, 30 L/MIN

SAMOA metered control valves are used at end of hose assembly for measured dispensing of lubricants and antifreeze solutions.

FLUIDS HANDLED

- Synthetic and mineral based lubricants.
- Gear Oil.
- Hydraulic oil and fluids.
- ATF.
- Antifreeze solutions.

MARKETS SERVED

- Car and truck dealerships.
- Fast lube and maintenance shops.
- Fleet service.
- Mining and construction.
- Lube trucks.

ACCURACY, DURABILITY AND HIGHER FLOW PERFORMANCE

- Extensively and rigorously field tested. Reliable performance.
- High precision machined measuring chamber with tight tolerances, quality gears and stainless steel shafts eliminate the need of calibration to adjust for fluid viscosity.
- Sealed battery compartment and isolated electronic register for extended life.
- Easy to read large character display, with batch, trip (resettable totalizer) and totalizer functions.
- Rough TPE boot surrounds the entire meter for even greater durability.
- Replaceable AAA batteries.



TECHNICAL DATA

Maximum flow rate	30 l/min (8 gal/min)
Accuracy	+/- 0,5 %
Maximum working pressure	100 bar (1,450 psi)
Operating temperature range	-10 °C to 60 °C (14 to 140 °F)
Fluid inlet	1/2" BSP (F)
Fluid outlet	1/2" BSP (F)
Wetted parts	Acetal / Aluminium / Stainless steel / NBR / Zinc plated steel / TPU / Polyamide
Fluid compatibility	Lubricants, ATF, antifreeze (Glycol) and antifreeze - water solutions
Weight	1,30 kg (2.86 lb)

ORDERING INFORMATION

HOSE END METER PART No.	OUTLET NOZZLE TYPE	OUTLET NOZZLE PART No.	
365 521	Hose end meter with no outlet	-	
365 536	60° rigid with quarter turn opening non-drip tip	369 232	(A)
365 535	Flexible outlet with 90° angled nozzle with automatic non-drip tip	369 230	(B)
365 534	Flexible outlet with 90° angled nozzle with quarter turn opening non-drip tip	369 228	(C)
365 532	Flexible outlet with automatic non-drip tip	369 224	(D)
365 537	Formable outlet with quarter turn opening non-drip tip	369 234	(E)
365 538	Formable outlet with quarter turn opening narrow non-drip tip (Ø 8 mm)	369 241	(F)

Non drip tips are manufactured in brass.

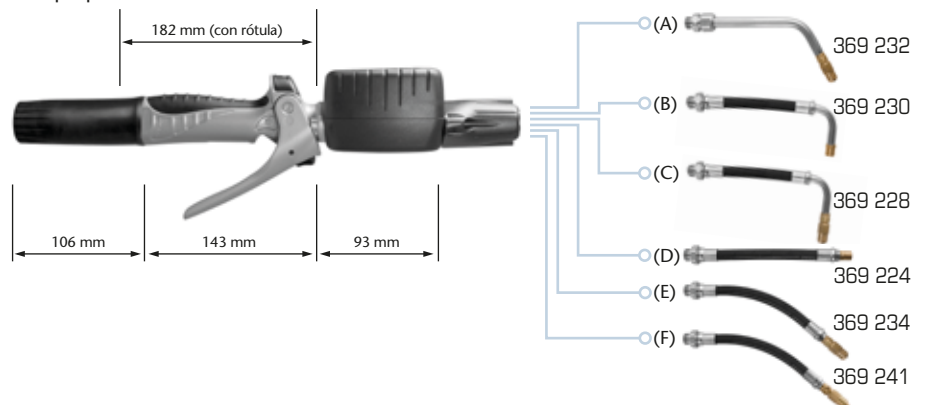

REGISTERED DESIGN

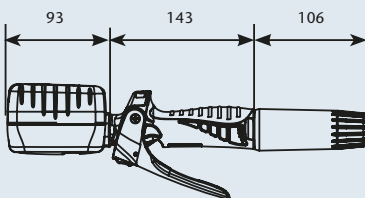

Dimensions (mm)

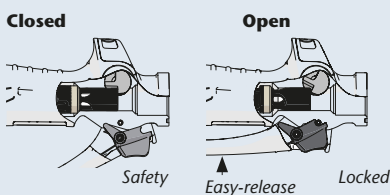

The new cam actuated piston-valve is designed for unrestricted flow and superb control. It incorporates an ergonomic trigger with safety, locking and easy-release functions.

ELECTRONIC METERED CONTROL VALVES FOR DISPENSING OIL AND OTHER FLUIDS

365 655

EC70 - OVAL GEAR WITH DIGITAL DISPLAY HAND HELD HIGH FLOW METER, 70 L/MIN



SAMOA High Flow metered control valves are used at end of hose assembly for measured dispensing large volume of lubricants and antifreeze solutions done at high flow rates.

FLUIDS HANDLED

- Synthetic and mineral based lubricants.
- Gear Oil.
- Hydraulic oil and fluids.
- ATF.
- Antifreeze solutions.

MARKETS SERVED

- Truck dealerships.
- Fleet service.
- Mining and construction.
- Lube trucks.
- Railroad and Mass Transit Vehicles.

ACCURACY, DURABILITY AND HIGH FLOW PERFORMANCE

- Extensively and rigorously field tested. Reliable performance.
- High precision machined measuring chamber with tight tolerances, quality gears and stainless steel shaft eliminate the need of calibration to adjust for fluid viscosity.
- Sealed battery compartment and isolated electronic register for extended life.
- Easy to read large character display, with batch, trip (resettable totalizer) and totalizer functions.
- Rough TPE boot surrounds the entire meter for even greater durability.
- Replaceable AAA batteries.

TECHNICAL DATA

Maximum flow rate	70 l/min (19 gal/min)
Accuracy	+/- 0,5%
Maximum working pressure	100 bar (1,450 psi)
Operating temperature range	-10 °C to 60 °C (14 to 140 °F)
Fluid inlet	3/4" BSP (F) or 1" BSP (F)
Fluid outlet	3/4" BSP (F)
Wetted parts	Acetal / Aluminium / Stainless steel / Zinc plated steel and brass / NBR
Fluid compatibility	Oil
Weight	2,85 kg (6.30 lb)

ORDERING INFORMATION

HOSE END METER PART No.	OUTLET NOZZLE TYPE	INLET SWIVEL THREAD	
365 655	30° rigid with semiautomatic non-drip tip	3/4" BSP (F)	(A)
365 654	Flexible outlet with semiautomatic non-drip tip	3/4" BSP (F)	(B)
365 657	30° rigid with semiautomatic non drip tip	1" BSP (F)	(A)
365 656	Flexible outlet with semiautomatic non drip tip	1" BSP (F)	(B)

REGISTERED DESIGN

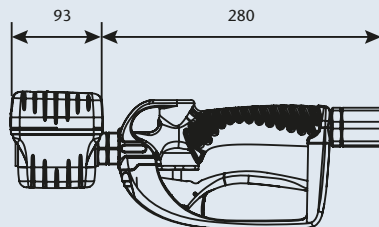

Dimensions (mm)

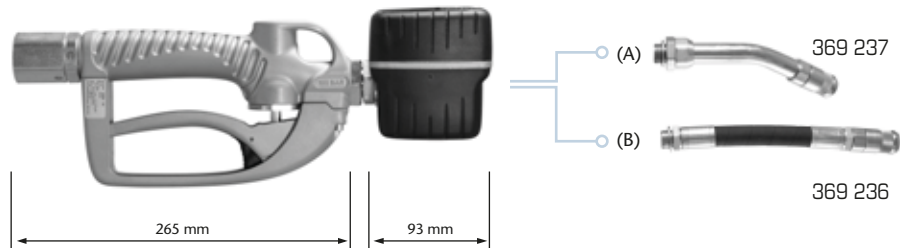

Closed

Open

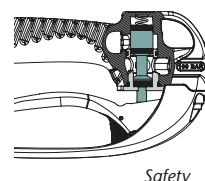

Safety

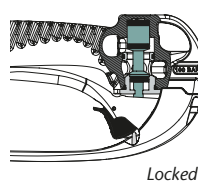

Locked

The new pressure balanced spool valve is designed for unrestricted flow, superb control and comfortable use. The control valve incorporates hand-guard for safety and an ergonomic trigger with locking function.

MECHANICAL METERED CONTROL VALVES FOR DISPENSING OIL AND OTHER FLUIDS

365 803

MC30 - ROTARY PISTON HAND HELD METER, 30 L/MIN

SAMOA mechanical metered control valves are used at end of hose assembly for measured dispensing of lubricants and antifreeze solutions in tough, intensive use applications.

FLUIDS HANDLED

- Synthetic and mineral based lubricants.
- Gear Oil.
- Hydraulic oil and fluids.
- ATF.
- Antifreeze solutions.
- Special model for antifreeze solutions available.

MARKETS SERVED

- Car and truck dealerships.
- Fast lube and maintenance shops.
- Fleet service.
- Mining and construction.
- Lube trucks.
- Railroad and Mass Transit Vehicles.



ACCURACY, DURABILITY WITH PROVEN PERFORMANCE

- Extensively and rigorously field tested. Reliable performance.
- No calibration required. High accuracy within a large viscosity range.
- One piece polycarbonate based integral register housing and single molded pointer knob guarantee maximum integrity of the meter against drops and impacts and provide superb protection against humidity.
- Fully mechanical register.
- Simple and easy to read dial includes 5-digit totalizer
- Very tough metal construction, the meter is ideal for intensive use and outdoor applications.
- PA40 control valve is flange coupled to eliminate the use of adaptors and eliminate leaks.

TECHNICAL DATA

Maximum flow rate	30 l/min (8 gal/min)
Accuracy	+/- 0,65 %
Maximum working pressure	100 bar (1,450 psi)
Operating temperature range	-10 °C to 60°C (-14 to 140 °F)
Fluid inlet	1/2" BSP (F)
Fluid outlet	1/2" BSP (F)
Wetted parts	Aluminium / Zinc alloy / Stainless steel / NBR / Brass / Steel / TPU / Polyamide
Fluid compatibility	Synthetic and mineral oils, ATF, Antifreeze, Gear oils
Weight	1,7 kg (3.74 lb)

ORDERING INFORMATION

HOSE END METER PART No.	OUTLET NOZZLE TYPE	OUTLET NOZZLE PART No.
METRIC METERS. 0 - 10 Liters dial, Totalizer in Liters - Lubricants		
365 801	No outlet. Includes inlet swivel with shroud	-
365 803	Flexible outlet with automatic non-drip tip	369 224
365 804	Formable outlet with quarter turn opening non-drip tip	369 234
METRIC METERS. 0 - 10 Liters dial, Totalizer in Liters - Antifreeze		
365 824	Formable outlet with quarter turn opening non-drip tip	369 234
QUARTS/GALLONS METERS. 4 - 16 Quarts dial, Totalizer in Gallons - Lubricants		
365 802	No outlet. Includes inlet swivel with shroud	-
365 805	Formable outlet with automatic non-drip tip	369 224
365 806	Formable outlet with quarter turn opening non-drip tip	369 234
QUARTS/GALLONS METERS. 4 - 16 Quarts dial, Totalizer in Gallons - Antifreeze		
365 826	Formable outlet with quarter turn opening non-drip tip	369 234

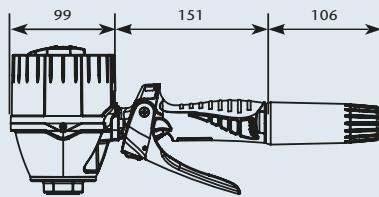

Dimensions (mm)

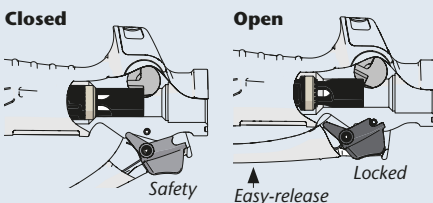

The new cam actuated piston-valve is designed for unrestricted flow and superb control. It incorporates an ergonomic trigger with safety, locking and easy-release functions.

Non drip tips are manufactured in brass. All models include inlet swivel with shroud and the outlet listed for each model.

MECHANICAL METERED PRESET CONTROL VALVES FOR DISPENSING OIL AND OTHER FLUIDS

365 811

MP30 - ROTARY PISTON HAND HELD PRESET METER, 30 L/MIN

SAMOA mechanical preset metered control valves allow automatic filling of large crankcases, engines and other lubricant reservoirs. For automatic operation, set the dial pointer to the quantity needed, actuate the trigger for automatic latching and the valve will deliver exactly the volume required and then shut off.



FLUIDS HANDLED

- Synthetic and mineral based lubricants.
- Gear Oil.
- Hydraulic oil and fluids.
- ATF.

MARKETS SERVED

- Truck dealerships.
- Fleet service.
- Mining and construction.
- Lube trucks.
- Railroad and Mass Transit Vehicles.

ACCURACY, DURABILITY AND EXTRA PERFORMANCE

- Extensively and rigorously field tested. Reliable performance.
- No calibration required. High accuracy within a large viscosity range.
- One piece polycarbonate based integral register housing and single molded pointer knob guarantee maximum integrity of the meter against drops and impacts and provide superb protection against humidity.
- The reset mechanism incorporates a safety clutch for preserving the preset mechanism in case the knob is turned in the wrong direction.
- Mechanical shut-off mechanism. High wear and stress resistant shut off mechanism.
- Simple and easy to read dial includes 5-digit totalizer
- Very tough metal construction, the meter is ideal for intensive use and outdoor applications.
- PA40 Control valve is flange coupled to eliminate the use of adaptors and eliminate leaks.

TECHNICAL DATA

Maximum flow rate	30 l/min (8 gal/min)
Accuracy	+/- 0,65 %
Maximum working pressure	100 bar (1,450 psi)
Operating temperature range	-10 °C to 60 °C (14 to 140 °F)
Fluid inlet	1/2" BSP (F)
Fluid outlet	1/2" BSP (F)
Wetted parts	Aluminium / Zinc alloy / Stainless steel / NBR / Brass / Steel / TPU / Polyamide
Fluid compatibility	Synthetic and mineral oils, ATF, Antifreeze
Weight	2 kg (4.40 lb)

ORDERING INFORMATION

HOSE END METER PART No.	OUTLET NOZZLE TYPE	OUTLET NOZZLE PART No.
METRIC METERS. 0 - 60 liters dial, totalizer in liters		
365 811	Rigid outlet with semiautomatic non drip tip	369 244
QUARTS/GALLONS METERS. 0 - 60 quarts dial, totalizer in gallons		
365 812	Rigid outlet with semiautomatic non drip tip	369 244
QUARTS/GALLONS METERS. 0 - 60 gallons dial, totalizer in gallons		
365 813	Rigid outlet with semiautomatic non drip tip	369 244

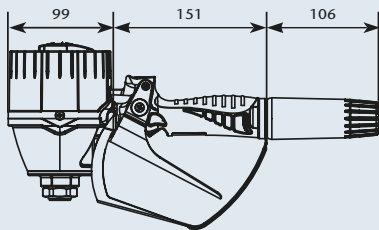

Dimensions (mm)

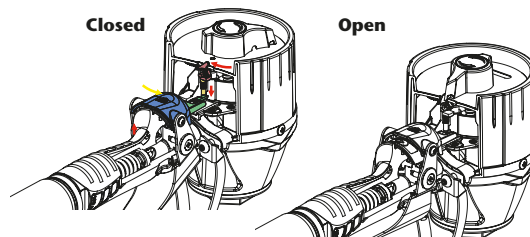

IN-LINE METERS

366 000 - 366 010 - 366 020

1/2" IN-LINE METERS C30, 30 - 50 L/MIN



REGISTERED DESIGN

Oval gear meters for use as in-line meters with oil, DEF / AdBlue®, windshield wash solution or anti-freeze solution, depending on the meter wetted materials. They can be wall mounted in the fluid line or at the pump outlet.

Meters include an electronic register controlled by wetted magnets and powered with two AAA alkaline batteries. It is shock proof and isolated from the fluid handled. Meter display is multi-function, showing the volume dispensed per delivery, and has a permanent and a resettable (trip function) totalizers. The display can be programmed to show delivery in liters, quarts, pints and US gallons. The assembly is enclosed in TPE moulded shroud.

MODELS AND TECHNICAL DATA			
	366 000	366 010	366 020
Wetted parts	ALUMINIUM , acetal, AISI 316 stainless steel, NBR	PVC , acetal, AISI 316 stainless steel, Viton®	AISI 316 STAINLESS STEEL , acetal, Viton®
Applications	Medium pressure dispense of lubricants up to 5.000 mPa	Low pressure dispense of DEF / AdBlue®, windshield wash and antifreeze solutions	Medium pressure dispense of DEF / AdBlue®, windshield wash and antifreeze solutions
Connection threads	1/2" BSP (F)	1/2" BSP (F)	1/2" BSP (F)
Flow range	1 - 30 l/min	1 - 50 l/min	1 - 50 l/min
Pulses per liter	164 ppl	150 ppl	164 ppl
Accuracy	+/- 0.5 %	+/- 0.5 %	+/- 0.5 %
Maximum operating pressure	100 bar	30 bar	100 bar
Temperature range (fluid)	-10 °C to 60 °C	-10 °C to 60 °C	-10 °C to 70 °C
Calibration	Can be calibrated	Can be calibrated	Can be calibrated
Weight	0,53 kg	0,50 kg	0,85 kg

366 060

3/4" HIGH VOLUME IN-LINE METER C70, 80 L/MIN



REGISTERED DESIGN

Oval gear meter for use as in-line meters with oil or diesel. It can be wall mounted in the fluid line or at the pump outlet.

Meter includes an electronic register controlled by wetted magnets and powered with two AAA alkaline batteries. It is shock proof and isolated from the fluid handled and the display is multi-function, showing the volume dispense per delivery and has a permanent and a resettable (trip function) totalizers. The display can be programmed to show delivery in liters, quarts, pints and US gallons. The assembly is enclosed in TPE moulded shroud. It can also be set to show the flow rate in units of measure per minute.

MODELS AND TECHNICAL DATA	
	366 060
Wetted parts	ALUMINIUM , acetal, AISI 316 stainless steel, NBR
Applications	Medium pressure dispense of diesel and lubricants up to 5.000 mPa
Connection threads	3/4" BSP (F)
Flow range	8 - 80 l/min
Pulses per liter	109 ppl
Accuracy	+/- 0.5 %
Maximum operating pressure	100 bar
Temperature range (fluid)	-10 °C to 60 °C
Calibration	Can be calibrated
Weight	0,80 kg

PULSE TRANSMITTERS

366 050 - 366 053 - 366 055

1/2" PULSE TRANSMITTERS, 30 - 50 L/MIN



Oval gear meters for use as in-line meters for oil, DEF / AdBlue®, windshield wash solution or anti-freeze solution lines depending on the meter wetted materials. They can be wall mounted in the fluid line or at the pump outlet.

Meters are shock proof and isolated from the fluid handled and the assembly is enclosed in a TPE moulded shroud.

Meter has a led light that indicates when the solenoid valve linked with the meter is open when used in an Inventory Management System.

MODELS AND TECHNICAL DATA			
	366 050	366 053	366 055
Wetted parts	ALUMINIUM , acetal, AISI 316 stainless steel, NBR	PVC , acetal, AISI 316 stainless steel, Viton®	AISI 316 STAINLESS STEEL , acetal, Viton®
Applications	Medium pressure dispense of lubricants up to 5.000 mPa	Low pressure dispense of DEF / AdBlue®, windshield wash and antifreeze solutions	Medium pressure dispense of DEF / AdBlue®, windshield wash and antifreeze solutions
Connection threads	1/2" BSP (F)	1/2" BSP (F)	1/2" BSP (F)
Flow range	1 - 30 l/min	1 - 50 l/min	1 - 50 l/min
Pulses per liter	328 ppl	320 ppl	320 ppl
Accuracy	+/- 0.5 %	+/- 0.5 %	+/- 0.5 %
Maximum operating pressure	100 bar	30 bar	100 bar
Temperature range (fluid)	-10 °C to 60 °C	-10 °C to 60 °C	-10 °C to 70 °C

REGISTERED DESIGN

05

VALVES AND METERS

366 057

3/4" HIGH VOLUME PULSE TRANSMITTER, 80 L/MIN



Oval gear meter for use as in-line meters for oil and diesel. It can be wall mounted in the fluid line or at the pump outlet. Double reed switch circuit board makes possible detecting when meter counts backwards.

Meters are shock proof and isolated from the fluid handled and the assembly is enclosed in a TPE moulded shroud.

Meter has a led light that indicates when the solenoid valve linked with the meter is open when used in an Inventory Management System.

MODELS AND TECHNICAL DATA	
	366 057
Wetted parts	ALUMINIUM , acetal, AISI 316 stainless steel, NBR
Applications	Medium pressure dispense of diesel and lubricants up to 5.000 mPa
Connection threads	3/4" BSP (F)
Flow range	8 - 80 l/min
Pulses per liter	109 ppl
Accuracy	+/- 0.5 %
Maximum operating pressure	100 bar
Temperature range (fluid)	-10 °C to 60 °C

REGISTERED DESIGN

OTHER METERS AND ACCESSORIES

365 300



PRESET DIGITAL METER

365 300 Preset digital meter

Oval gear hose end meter with preset function. Preset mode dispensing allows hands off operation as the meter automatically shuts off once the preset volume is delivered. Meter with digital display, works with four easy to replace 1,5 V AAA alkaline batteries. Includes inlet swivel and rigid outlet with non drip nozzle.

365 575



HOSE END METER FOR WATER BASED FLUIDS

365 575 Hose end meter for water based fluids

Oval gear hose end meter with electronic display for measured delivery of windshield washer, coolant and antifreeze solutions. Display is powered with two easy to replace 1,5 V AAA alkaline batteries. Meter can measure in liters, quarts, pints and US gallons. The meter is flange coupled delivery gun 186 300. Fluid inlet: 1/2" BSP (F). Maximum flow: 30 l/min. Maximum working pressure: 30 bar. Operating temperature range: 10 to 60 °C (14 to 140 °F).

186 300



DELIVERY GUN FOR WATER BASED FLUIDS

186 300 Delivery gun for water based fluids

Delivery gun with reinforced polyamide body and stainless steel valve mechanism for use with fluids like windshield wash solutions, glycol solution (anti-freeze and other water based solutions). Includes brass inlet swivel with 1/2" BSP (F) connection thread and flexible outlet with 90° angled nozzle with quarter turn opening / closing non-drip tip.

05

VALUES AND METERS



369 224



369 228



369 230



369 232



369 234

369 241



369 244

ACCESSORIES 1/2" CONNECTION THREAD OUTLETS

They fit all metered and non-metered oil guns EC30, PA40, MC30 and MP30. Connection thread: 1/2" BSP (M). Non drip tips are manufactured in brass.

369 224 Flexible outlet with automatic opening / closing non-drip tip.

369 228 Flexible outlet with 90° angled nozzle with quarter turn opening / closing non-drip tip.

369 230 Flexible outlet with 90° angled nozzle with automatic opening / closing non-drip tip.

369 232, 60° rigid outlet with quarter turn opening / closing non-drip tip.

369 234 Formable outlet with quarter turn opening / closing narrow (Ø 8 mm) non-drip tip.

369 241 Formable outlet with quarter turn opening / closing narrow (Ø 8 mm) non-drip tip.

369 244 Rigid straight outlet with semiautomatic non-drip tip. For MP30 mechanical preset meter.

369 606 Pack of four color coded protectors. For mounting at the EC30 meters and PA40 oil gun outlets.

369 606



369 236 - 369 237



ACCESSORIES 3/4" CONNECTION THREAD OUTLETS

They fit all EC70 and PA70 metered and non-metered guns. Connection thread: 3/4" BSP (M) and bonded washer seal.

369 236 Flexible outlet with semiautomatic non-drip tip.

369 237, 30° angled rigid outlet with semiautomatic non-drip tip.

413 077

415 002



GREASE CONTROL GUNS

413 077 Grease control gun

Grease control gun with rigid outlet with 3 jaw connector (PN 121 050).

413 080 Grease control gun with z-swivel

Grease control gun with z-swivel (PN 414 300), rigid outlet and 3 jaw connector assembly (PN 741 300).

413 081 Grease control gun

Grease control gun with 450 mm double steel braid reinforced rubber hose (PN 140 050) with 3 jaw connector (PN 121 050).

413 082 Grease control gun with z-swivel

Grease control gun with z-swivel (PN 414 300) and 450 mm double steel braid reinforced rubber hose (PN 140 050) with 3 jaw connector (PN 121 050).

ELECTRONIC-METERED GREASE CONTROL GUNS

415 002 High pressure grease electronic-metered control gun

Includes:

Double steel braid reinforce rubber hose (400 mm) with hydraulic grease connector and Z-swivel.

415 000 High pressure grease electronic-metered control gun

Includes:

Z-swivel, with no outlet accessories.

High pressure grease control guns with ergonomic body and trigger designed to reduce operator hand fatigue. Manufactured in aluminium with steel insert for high pressure. Maximum working pressure: 500 bar (7,150 psi). Inlet thread: 1/4" BSP (F). Outlet thread: 1/8" BSP (F).

414 300 - 414 100



GREASE CONTROL GUN SWIVELS

Equipped with ball bearings for easy articulation even at high pressure. For best results, use a straight swivel between the pump and distribution hose and Z swivel between the hose and grease control gun. Maximum working pressure: 500 bar (7,150 psi).

414 100 Straight grease swivel. 1/4" BSP (MF).

414 200 "L" grease swivel. 1/4" BSP (MF).

414 300 "Z" grease swivel. 1/4" BSP (MF).

140 050 - 741 300



GREASE CONTROL GUN OUTLETS

741 306 Rigid outlet with hydraulic grease connector.

741 300 Rigid outlet with 3 jaw hydraulic grease connector (121 050).

140 050 Double steel braid reinforced grease hose, 450 mm.

741 304 Rigid outlet.

411 100



OVAL GEAR IN LINE GREASE METER WITH ELECTRONIC DIGITAL DISPLAY

411 100 In line grease meter

High pressure oval gear meter with digital display. Batch display in grams (up to 9999 g) and permanent totalizer in kilograms (up to 999999 kg).

Works with two 1,5 V AAA alkaline batteries. Maximum pressure: 500 bar (7,140 psi).

Maximum flow range: up to 1 kg/min (2.2 lb/min). Accuracy: ± 3,0 %. Inlet and outlet connections: 1/8" BSP (F).

361 200 - 361 100

OIL BAR AND SPIGOT VALVE
361 200 Oil bar

Oil bar to dispense up to four products. Delivered with one outlet, up to three additional outlets can be mounted.

361 110 Additional outlet for oil bars
366 550 In-line meter kit for oil bars
361 100 Oil spigot valve

For connecting to pumps outlet. Connection thread 3/4" BSP (M).

186 000 - 185 001 - 186 010

WATER GUNS

For use only with water and antifreeze solutions.

186 000 Water gun

Maximum working pressure 10 bar, connection thread 1/4" BSP (F).

186 010 Water bib

Maximum working pressure 10 bar, connection thread 1/4" BSP (F)

185 001 Wash gun

Maximum working pressure 30 bar, connection thread 1/2" BSP (F).

187 000 - 187 001

SPRAY GUNS
187 000 Spray gun

Min. - max. pressure: 3 to 10 bar, connection thread 1/4" BSP (F). Aluminium gun body and 1 liter aluminium container.

187 001 Spray gun

Min. - max. pressure: 3 to 10 bar, connection thread 1/4" BSP (F). Aluminium gun body, metal outlet and 1 liter plastic container.

184 000 Spray gun

Min. - max. pressure: 4 to 10 bar, connection thread 1/4" BSP (F). Plastic gun body, metal outlet and 0.75 liter plastic container.

184 050 Spray gun

Min.- max. pressure: 4 to 10 bar, connection thread 1/4" BSP (F). Plastic gun body, plastic outlet and 0,75 liter plastic container.

188 000 - 188 100

INDUSTRIAL QUALITY BLOW GUNS

Aluminium blow guns with anti-slide grip. High air flow and wide range of accessories. Maximum minimum pressure: 3 to 8 bar, connection thread: 1/4" BSP (F). Includes extra-quite nozzle.

188 000 Heavy Duty blow gun
188 100 Compact blow gun
Blow guns accessories:
180 801 High flow nozzle

180 802 Extra-quite nozzle (standard in Industrial Quality blow guns).

180 803 Anti splash protection
180 800, 150 mm extension tube

Two or more tubes can be combined for getting an extra large tube.

184 200 - 184 201

THERMOPLASTIC BLOW GUNS
184 200 Thermoplastic blow gun

1/4" BSP (F).

184 201 Thermoplastic blow gun with flow regulator

1/4" BSP (F).

199 800

TIRE INFLATOR GUNS
195 100 Approved tire inflator

Tire inflator approved following 86 / 217 CEE directive. 500 mm rubber hose with connecting clip.

Connection thread: 1/4" BSP (F).

199 800 Standard tire inflator

650 mm rubber hose with connecting clip.

Connection thread: 1/4" BSP (F).

ADVANCED MONITORING SYSTEM	82
ADVANCED MONITORING SYSTEM. BASIC COMPONENTS	84
ADVANCED COMMUNICATION PLATFORM AND ACCESSORIES	85
TANK LEVEL CONTROL SOLUTIONS	86
INVENTORY MANAGEMENT CONSOLE	88
SPECIAL AMS VERSION	89
PRESET DOSING MODULE	90



ADVANCED MONITORING SYSTEM

AMS - INVENTORY MANAGEMENT CONTROL SYSTEM

It is more than likely that your stock control for parts and consumables is well established, with charges for those items passed to customers as a matter of course. But can you reconcile your oil purchases and oil sales and consumption? Do you know where every litter of oil is used? Do you know how much just «disappears»? With current retail oil prices for sure it is worth to find out.

SAMOA Advanced Monitoring System (AMS) is an Inventory Management Control System that puts you in total control of the fluids usage for any vehicle servicing activity. With this system, and when used in combination with efficient pumps, hose reels, dispense valves and other SAMOA lubrication equipment, you can reliably manage all the fluids used in your shop: lubricants, AdBlue®/DEF, windshield wash, coolants, diesel, etc. Depending on your fluids usage, you will be surprised how the entire system can pay for itself. After this period, the system contributes to increase your operation profitability.

AMS is a hard wired system, providing efficient and reliable data and power transmission among all the system components. All hassles coming from wireless communications and interferences from other machinery in the workshop are removed as well as power drop off a consequence of low batteries.

The entire system can be controlled through a PC using a PC interface and communications adaptor together with special software (AMS Win PC). The AMS system can also integrate the Advanced Tank Management System (TRM or ATS). This allows an accurate and real time control of the inventories and an automatic update whenever lubricants are delivered. The AMS also has the possibility to communicate with the workshop Data Management System using an additional software module (ACP).

From the simplest entry level console to the most sophisticated computerized management system, we can supply the equipment required for the Professional Management of both new and used fluids.



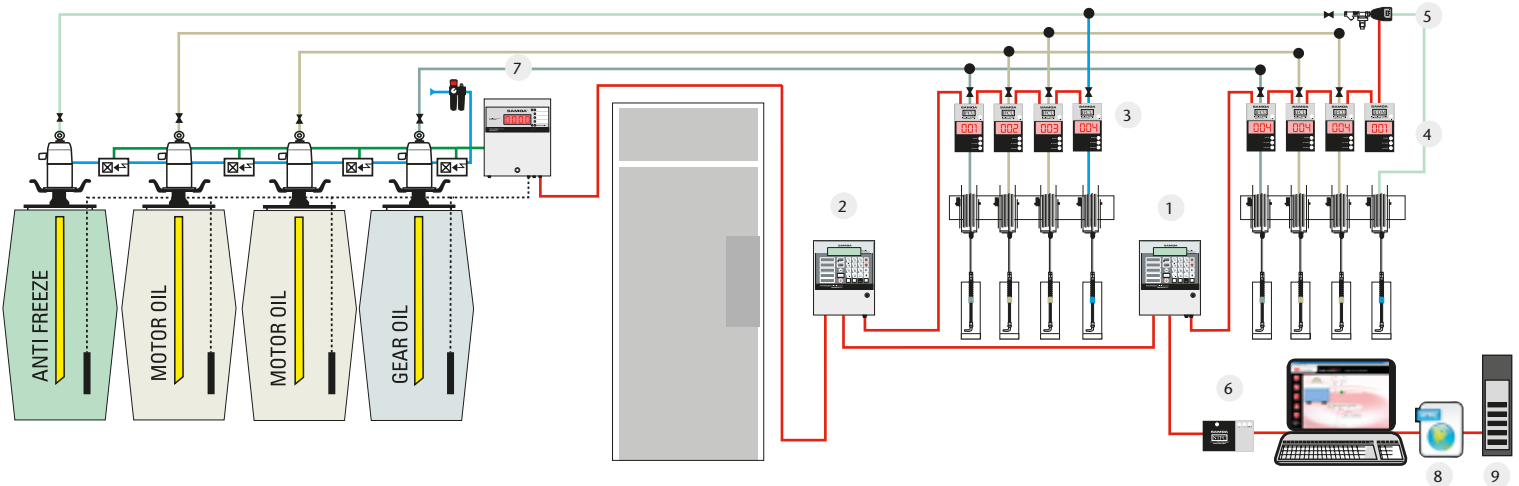

- 1 AMS, ACCESS KEYPAD WITH AMM, APPLICATION SOFTWARE MEMORY MODULE (PN 381 000 + PN 381 600).
- 2 AMS, ACCESS KEYPAD WITHOUT PRINTER (PN 381 000).
- 3 IFCU, INTELLIGENT FLOW CONTROL UNIT (PN 381 500).
- 4 IFDM, INTELLIGENT FLUID DISPENSE MANAGER (PN 381 550).
- 5 FCU, FLUID CONTROL UNIT FOR FLUIDS (380 551).
- 6 NTPC, NETWORK PROTOCOL CONVERTER (PN 381 351 BASIC), (PN 381 352 PROFESSIONAL), (PN 381 353 PREMIUM).
- 7 TRM, TANK ROOM MANAGER (PN 382 100 + PN 382 120).
- 8 ACP PLATFORM (PN 381 66X).
- 9 DMS, DATA MANAGEMENT SYSTEMS SERVER.

THE AMS IS DESIGNED TO SATISFY THE NEEDS OF:

- A - The user**, who will be guided during the delivery transaction by a rolling menu and who will have access to innovative functions such as: automatic identification by coded key, multi-fluid delivery under one work order and top up option on request.
- B - The supervisor**, who will have access to a wide variety of parameters that will allow him to set up the system management criteria which best meets his specific needs. Through easy to use PC software, he will be able to modify operator authorizations, adjust tank levels and access a wide range of statistics.
- C - The installer**, he will be able to easily install and set up the system. Directly connected to the main electricity supply (115 / 230 VAC), the AMS keypad has an internal 24 VDC power supply that provides the electrical power to between 1 and 8 outlets maximum, depending on the distance. The number of keypads in a system depends on the layout of the workshop and is not limited. The AMS can manage up to 100 outlets, each equipped with an Intelligent Flow Control Unit.



381 000 - 381 600 - 381 950

381 500

381 352



ACCESS KEYPAD

To be mounted in the workshop to provide technicians with remote access to outlets or reels. Access keypads include a coded key reader for user identification. As an option, a bar code reader can be connected to the access keypad for user identification, job order or job description registration. The access keypad also includes a slot for housing the application software memory module (PN 381 600): One software memory module is required for each installation. Sturdy metal casing for durability, 25 key alphanumeric keyboard and 2 x 16 digit back lighted LCD display.

381 000 AMS Access keypad (Voltage input: 115 - 230 VAC)

381 600 AMM, Application software memory module

To be inserted into its slot in the access keypad, includes the system operating software. One memory module must be used with every system.

381 950 Cable for Can Bus, 1 m

INTELLIGENT FLOW CONTROL UNIT (IFCU)

The IFCU controls all parameters related with the distribution of fluids and integrates in one single module all of the following elements:

- A large capacity filter, easily accessed for cleaning.
- A double channel pulse transmitter for accurate and reliable metering.
- A solenoid valve to control the fluid line.
- A microprocessor CPU for the fluid outlet management.
- A large 3 digit high visibility display that shows the volume dispensed during the transaction and the outlet number when the outlet is not in use.
- Three LED lights that show the IFCU status.

The IFCU connection to the fluid distribution line is done through 1/2" threaded ports. Its connection to the electronic network is done through 2 standard plug-in electrical connectors (network IN / network OUT).

381 500 Intelligent Flow Control Unit with CAN controller 100 PPL and installation accessories

Includes electrical connectors and two 90° fittings for connection to the fluid distribution line. Connection threads: 1/2" BSP (F).



AMS WIN PC 3.0 + NETWORK PROTOCOL CONVERTER (NPTC)

The network protocol converter allows reliable communication with a PC through an USB connector. The AMS Win PC software is delivered with the NPTC. The software runs on a WINDOWS operating system and uses ACCESS database.

THREE LEVELS / VERSIONS OF SOFTWARE

381 351 Basic version

This version allows:

- System parameters configuration.
- Declining balance Inventory Control and manual adjustment.
- List and sort of transaction.

381 352 Professional version

Includes all features in Basic version Plus:

- Automatic, real time, inventory control and adjustment using additional TRM or ATS.
- Export transactions to an excel file.

381 353 Premium version

Includes all features in Professional version Plus:

- Unlimited transactions prepared in advance (VPT).
- DMS Integration using ACP (.TXT; OBDC; XML).



381 351

BASIC

381 352

PROFESSIONAL

381 353

PREMIUM

ACP INTERFACE (WEB SERVICE)

- The ACP program allows the AMS Win PC Software to interconnect with the most popular data management systems (DMS) in the market, offering an efficient bidirectional communication.
- Web service interface developed using communication standards (SOAP).
- Single or multiple validation of transactions (ex: Job Number, Oil Type, Litres, etc.).
- Export of all transactions data to the customer DMS.
- Other communication formats available (only single validation), such as:
Text Files (.TXT) or Database (.ODBC)
- Contact your SAMOA Distributor who will assist you with the ACP software you need.

VALIDATION, Single or multiple fields



DATA EXPORT TO DMS, Transaction completed



381 102



381 102 Additional power supply box

Each access keypad has a power supply box that provides energy to the system for opening and closing up to eight solenoid valves. An additional power net box is required when one single keypad needs to control more than eight hose reels or if the distance between the keypad and the last IFCU is too long.

381 700



381 700 Remote display unit (RDU)

High visibility 3-digit display, identical to the IFCU display. It displays in real time the delivery details of any transaction in a remote location. It is particularly useful when a hose reel is mounted onto a frame, which can be used from both sides. One RDU can display the delivery of any IFCU present on the network.

381 550



381 550 Intelligent fluid dispenser Manager (IFDM)

The IFDM manages the flow control units whenever the system requires a special pulse meter or solenoid valve (type of fluid, flow rate, pressure, etc.). It has the same electronic management functions as the IFCU.

381 905



381 901



381 912



736 349

ACCESSORIES

381 905 Five coded keys set

381 901 Bar coded reader

381 200 Thermal ticket printer Ticket printer for installation inside the access keypad.

381 950 Cable for CAN bus Communications cable to connect system elements, adequate in most installations.

736 353 Wall bracket for 381 000 or 381 001 Keypads for wall mounted applications.

381 912 IFCU bracket for open reels (501 and 504 series) for wall mounted applications.

736 349 Bracket for mounting up to 6 IFCUs (381 500) on top of a six hose reel stand. Requires brackets 381 911 and 381 910 and cover 736 377.

381 911 IFCU bracket. Use together with 736 349.

381 910 IFDM or remote display (RDU) bracket. Use together with 736 349.

736 377 Cover It covers the open area of bracket 736 349 when no IFCU is installed.

382 100

TANK ROOM MANAGER



Control module to monitor the volume in up to four tanks using barometric level sensors. The level sensors provide accurate measurement of the volume in each tank. The system can work as a stand-alone unit (TRM S/A) or as part of the Advanced Monitoring System AMS (TRM-NET). Four System modules can be connected together to monitor up to 16 tanks.

TRM-NET

When used with an AMS system, the TRM-NET is connected directly via the CAN-BUS network to any keypad of the installation (AMM version 3.1.3 or higher) and it transmits automatically accurate real time information about the level in the oil tanks increasing system security and reliability of the oil inventories. This way manual inventory adjustment is no longer required, for example when new oil is supplied into a tank.

Additionally the TRM-NET can open and close the compressed air supply valves up to four individual air operated pumps (using solenoid valves PN 389 013 or PN 389 012) securing that the fluid pipe line will be under pressure only when there is a request of fluid coming from one of the keypads. The TRM-NET can also control one general air solenoid valve.

382 100 Tank Management System module TRM-NET

382 120 Level sensor

Tank maximum depth 400 cm.

389 013 Compressed air solenoid valve, 1/2" BSP (FF)

10 bar working pressure. For PM4, PM45 and PM60 pumps.

389 012 Compressed air solenoid valve, 1/4" BSP (FF)

10 bar working pressure. For PM2 pumps.

TRM-S/A

When used as a stand-alone unit, the system is set up using an access keypad (PN 382 110). This keypad is used to set up tank parameters and minimum alert levels. Optionally, the TRM S/A can be controlled and set up from a PC using the AMS-WinPC Professional software pack (PN 382 352) that includes the network protocol converter (NTPC) to communicate with a PC through a USB serial port.

382 101 Tank Management System module TRM S/A

382 110 Tank Management System access keypad

382 120 Level sensor

Tank maximum depth 400 cm.

381 352 PC software kit

Includes software and NTPC.

382 120



389 013



382 001

TANK ALERT SYSTEM



Protects the waste oil tanks from overflow and the air operated pumps for new oil tanks from running dry. The module can accept up to four tank level contact sensors, e.g. three low level sensors in fresh oil tanks and one high level sensor in a waste oil storage tank. The unit includes four LED indicators and an acoustic alarm signal warning when each of the tanks reaches a critical level. It has two 24 V outlet for controlling solenoid valves and one 12 V outlet for connecting to a remote flash and acoustic alarm (PN 382 005). The system can work as a stand-alone unit (ATS Basic+) or as part of the Advanced Monitoring System AMS (ATS-NET).

ATS Basic+

When used as a stand-alone unit, the system can control up to two solenoid valves. On a waste oil tank it prevents overflow by closing a driven valve (PN 389 020). With new oil tanks it can open and stop the compressed air supply to the air operated pumps (using a solenoid valve PN 389 013) preventing the pumps from running dry.

382 001 Tank Alert stand alone module

382 201 Height adjustable contact level sensor

With 5 m cable and 2" BSP (M) connection.

382 005 Remote flash and acoustic alarm

389 020 Driven valve 1 1/2" BSP (F) kit

Air solenoid valve 24 VAC included. For controlling waste oil delivery into the waste oil storage tank.

ATS-NET

When used with an AMS system, the ATS-NET is connected directly via the CAN-BUS network to any keypad of the installation (AMM version 3.1.3 or higher) and it transmits automatically an alarm signal, increasing system security, and preventing running out of stock. Additionally the ATS-NET can open and close the general compressed air supply to all air operated pumps (using a solenoid valve PN 389 013).

382 050 Tank Alert module ATS-NET

382 201 Height adjustable contact level sensor

With 5m cable and 2"BSP(M) connection.

382 005 Remote flash and acoustic alarm

389 013 Compressed air solenoid valve

382 201



382 005



389 020

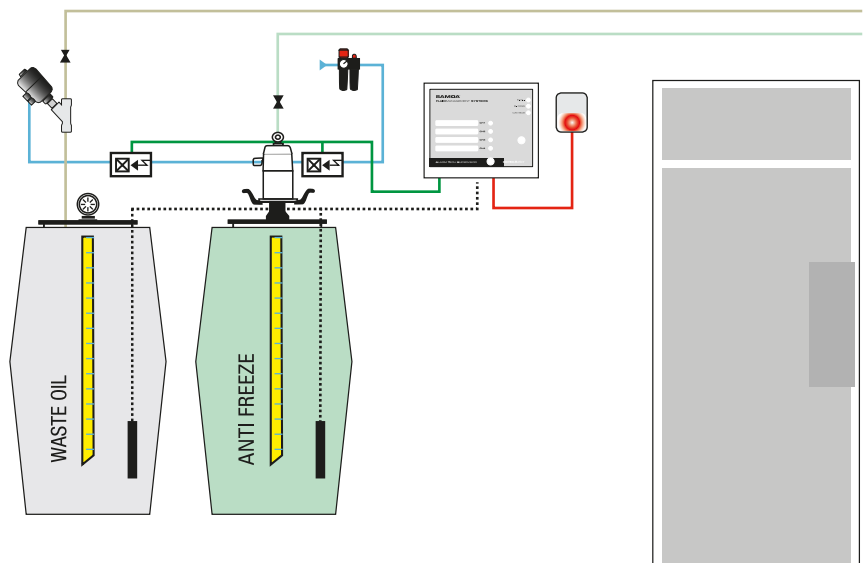

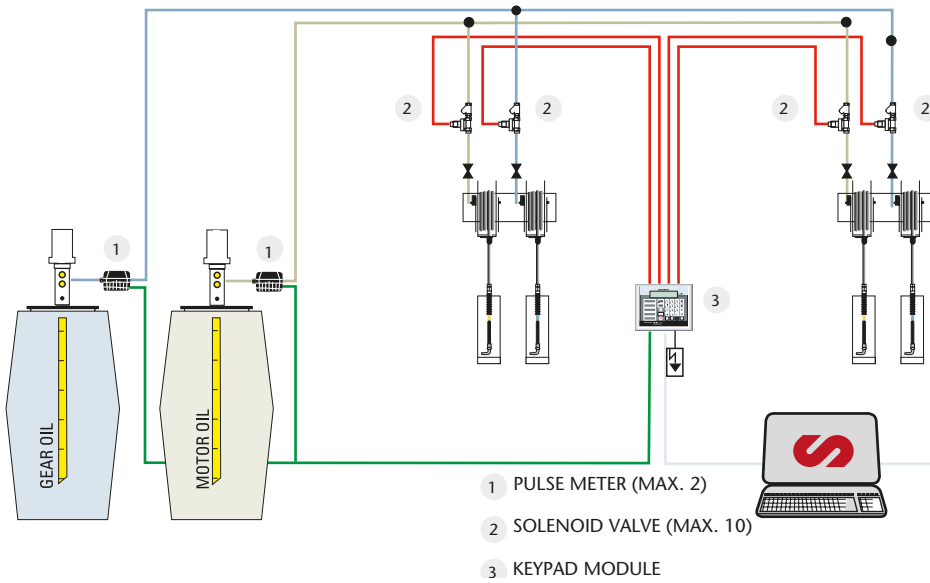

381 002

IMC COMPONENTS

381 002 Inventory management console module - 230 V

Access keypad designed to monitor and control fluid dispenses in a workshop from a single or central location. It can control a total of 10 different outlets with two different fluids. The unit tracks fluid dispenses for every single work order and provides additional information regarding each fluid such as current stock, reorder level and stop level. The IMC can also manage a solenoid valve to control the air powering the pumps, either according to a service planning schedule or from a command entered on the keypad by a manager. Four float type level switches provide the signals to control waste fluid levels in two waste fluid tanks and prevent overflow of used oil by disabling the waste product pump.

381 004 Inventory management console module - 115 V

Same as 381 002 for 115 V.

381 003 Inventory management console module with PC connection - 230 V

Similar to model 381 002 plus includes a validation chip and PC software that enables the setting and maintaining of system parameters through a PC. Also, the PC can alert the oil vendor or shop Purchasing Department with an email when the oil inventory level is low.

381 005 Inventory management console module with PC connection - 115 V

Same as 381 003 for 115 V.

This single keypad system is designed for shops that want simple control of their fluids. IMC offers ease of operation, great value and several features not previously available in entry level Fluid Management and Control System.

IMC works with one pulse meter at each pump (maximum two pulse meters) and a solenoid valve at each fluid outlet (maximum 10 solenoid valves in total). The system does not allow simultaneous operation of outlets with the same fluid; however different fluids can be dispensed simultaneously.

An upgraded Inventory Management Console, which allows connection to a PC, is available. PC connection makes setting and maintaining the system parameters easier and it is a powerful inventory control tool that allows tank level monitoring to alert the oil vendor or the shop purchase department with an email when the oil inventory level is low.

IMC standard features and capabilities are:

- Controls one or two fluids and up to 10 dispense points. Manages simultaneous dispensing of two different fluids.
- Up to 200 users, system access through pin number or coded key.
- Allows control of one air valve, so air supply is only available during service operating hours.
- Inventory management on a declining balance: allows initial inventory to be entered and deducts for each dispense. Manager needs to enter each delivery and the console alerts when inventory level is low.
- Two operation levels, user and manager levels. At user level it is only possible to order a dispense. At manager level is possible to adjust inventory levels, set inventory warning levels and perform other management functions.
- The system requires 115 or 230 VAC mains power.
- Can work with metric or US units of measure.



366 050

366 050, 1/2" Pulse meter for oil

Oval gear meter for use with oil, or antifreeze. Meters are shock proof and isolated from the fluid handled and the assembly is enclosed in a PTE molded shroud. For being connected at each pump outlet.

Inlet - Outlet: 1/2" BSP (FF).
Min. - Max. flow rate: 1 - 30 l/min.
Max. working pressure: 100 bar.
Pulses per litre: 328.



366 055

366 055, 1/2" Stainless steel pulse meter

Oval gear meter for use with windshield wash solutions, antifreeze or AdBlue® / DEF. Meters are shock proof and isolated from the fluid handled and the assembly is enclosed in a PTE molded shroud. For being connected at each pump outlet.

Inlet - Outlet: 1/2" BSP (FF).
Min. - Max. flow rate: 1 - 50 l/min.
Max. working pressure: 100 bar.
Pulses per litre: 320.



389 001

389 001 Solenoid valve

24 VDC solenoid valve for oil and antifreeze (glycol). Inlet - Outlet: 1/2" BSP (F). Max. working pressure: 50 bar (715 psi).

389 004 Solenoid valve

24 VDC Solenoid valve made in Stainless steel for AdBlue®/DEF or windshield wash. Inlet-outlet 1/2" BSP (FF). Working pressure: 10 Bar.

ADVANCED MONITORING SYSTEM 12 V



This AMS version enables to control and measure the fluid dispensed through up to 6 hose reels per MFDM-LD 12 V (PN 382 113) . It is required a 12 VDC solenoid valve and pulse meter per hose reel.

System requires a 12 V AMS access keypad (PN 381 013) and an AMM, Advance Module Memory (PN 381 600). A display included in the MFDM-LD-12 V shows the number of the corresponding hose reels when the unit is inactive, and the quantity dispensed when a transaction is being performed.

Simultaneous dispenses can be performed, but only the first one will be showed in the display (one or more RDUs can be used too). Two or more MFDM-LD 12 V can be connected to the same network.

The system can be used in vans and trucks providing 12 VDC power supply. This AMS version can be connected to a PC through a standard Samoa NTPC and any of the software version level (PN 381 351 - PN 381 352 - PN 381 353)

381 013 AMS, Access keypad with ticket printer (Voltage input: 12 VDC)

382 113 MFDM, Multi-Fluid Dispense Manager with 4 digits display (Voltage input: 12 VDC)

To be used with 12 V Access keypad (PN 381 013). Provides control to up 6 outlets.

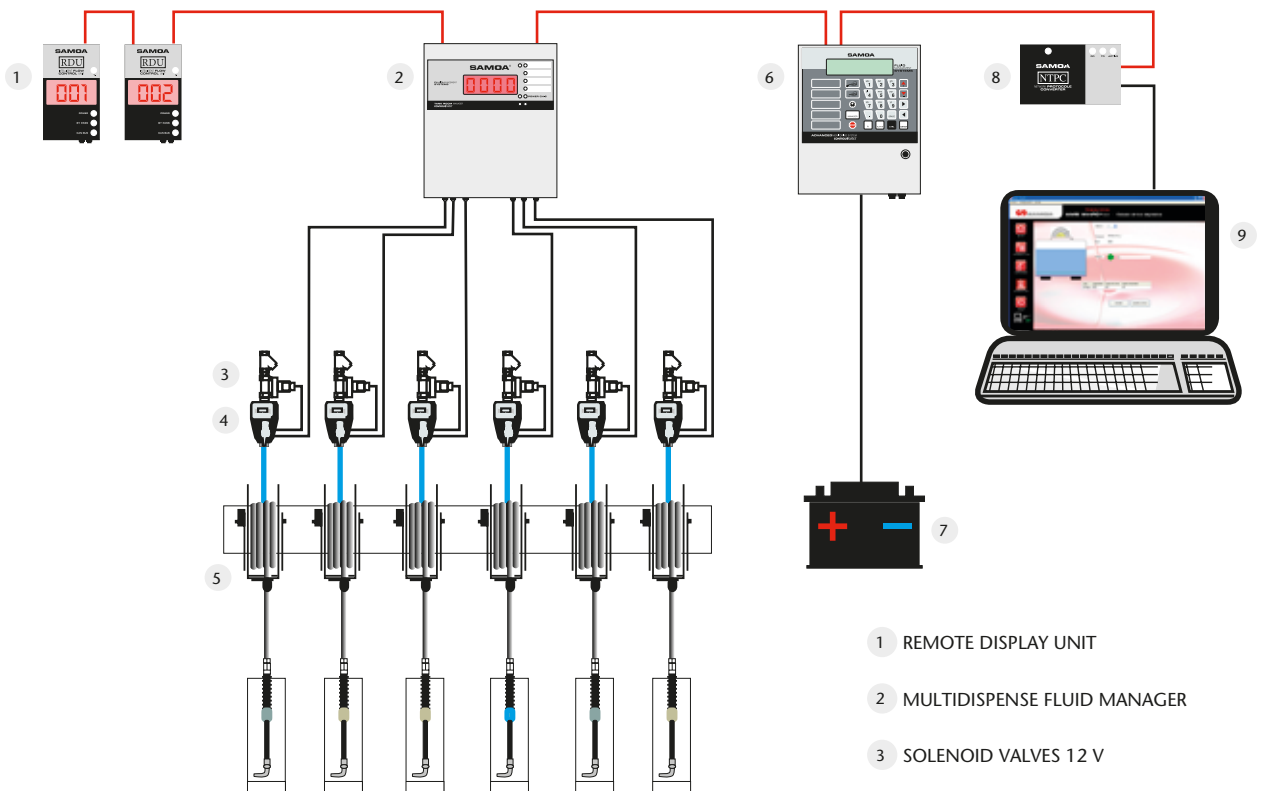

- 1 REMOTE DISPLAY UNIT
- 2 MULTIDISPENSE FLUID MANAGER
- 3 SOLENOID VALVES 12 V
- 4 PULSE METER
- 5 HOSE REELS
- 6 AMS, ACCESS KEYPAD 12 V + AMM
- 7 12 VDC POWER SUPPLY
- 8 NETWORK PROTOCOL CONVERTER
- 9 PC RUNNING AMS - WIN PC SOFTWARE

381 030

ELECTRONIC PRESET DOSING MODULE DPS-16



381 030 Electronic preset dosing module

Preset dosing unit for industrial applications that helps you to accurately deliver the correct amount of fluid. It reduces the amount of key/button inputs required to obtain the required volume delivered. It can be used with a wide variety of fluids.

The module consists on a very robust, «vandal proof», button box (nickel coated brass buttons) and a remote display that shows the volume dispensed and the preset program selected. Buttons are used to select the preset program and to program the system. It can store up to 16 different pre-set volumes.

It is an open system and it can work with a wide range of fluids. It accepts any pulse meter from 1 to 6553 pulses per unit and can also work with 24 VDC solenoid valves in different sizes and materials to control the fluid delivery either by closing the fluid line or the pump air supply.

TECHNICAL SPECIFICATION

Power supply	100 - 230 VAC 50/60 Hz
Solenoid valve output	24 VDC, max. 1 A
Pulse per unit	1 - 9999
Calibration	From buttons
Pre-set adjust	From buttons
Number of pre-sets	16
Number of decimals	0, 1, 2, 3, 4, or AUTO
Time out	4 minutes

FLUIDS HANDLED

Mineral and synthetic based lubricants, grease hydraulic and transmission fluids, cutting oils antifreeze and coolant solutions, detergents, Solvents

APPLICATION

Assembly lines in general industry
Filling stations

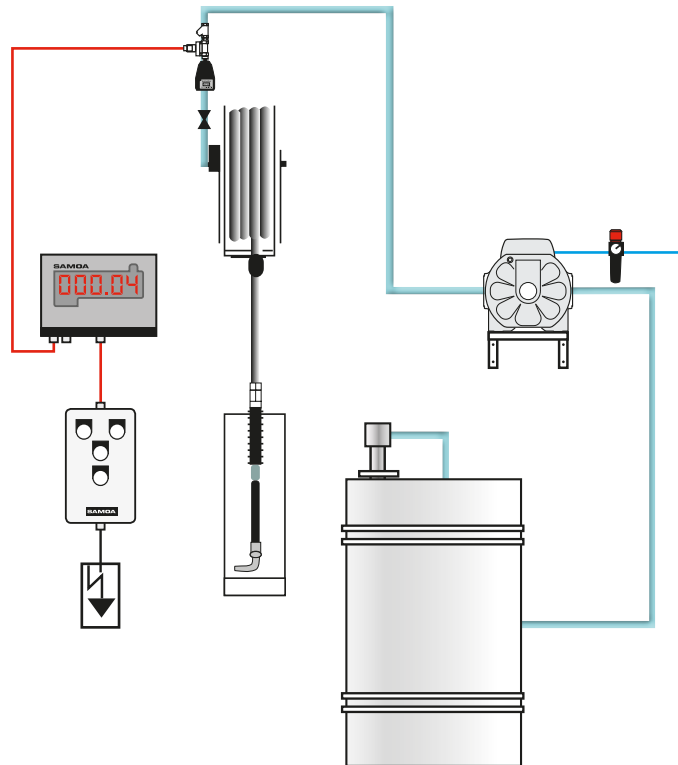

USED FLUID COLLECTION UNITS	92
WASTE OIL SUCTION AND GRAVITY RECEIVERS, 100 AND 70 LITRES	93
WASTE OIL DRAIN UNITS	94
WASTE OIL EVACUATION PUMP KITS	95
WASTE OIL EQUIPMENT ACCESSORIES	96





USED FLUID COLLECTION UNITS

Mobile units designed for the collection of used fluids like motor oil, gear oil, antifreeze and coolant fluids as well as other no aggressive A-III class automotive fluids.

Models for gravity collection are fitted with a telescopic bowl and they can be used under vehicle hoists or inside lubrication pits for collection of the used fluid.

Models fitted with a pneumatic vacuum pump can be used for extracting waste oil through the vehicle motor oil dipstick tube using an adequate adaptor or suction cane. The pneumatic suction pump has no moving, no wear parts, and can achieve up to 80% vacuum. Suction units include a complete set of suction canes and adaptors.

Once full, the reservoir can be discharged either using a remote pump through a hydraulic type connector fitted to the bottom of the unit, with a piston pump attached to the unit or pressurizing the unit reservoir at 0,5 bar (3.5 psi) maximum with a tire inflator.

100
LITRES

COMMON FEATURES

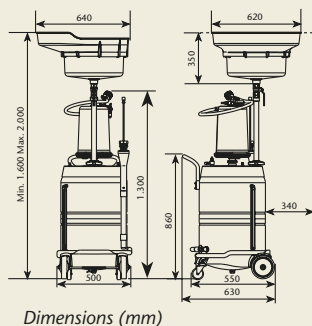

- 100 litres (26 gallons) capacity steel reservoir, with side level gauge.
- Tray for tools, washers, plugs, etc. on top of the reservoir.
- One piece molded spoiler for securing the discharge hose in pressure discharge models.
- Two reinforced casters and two reinforced fixed wheels.
- Steel tank with epoxy powder coating.
- Models for gravity collection include a telescopic collection bowl, with an oversized 360° positionable composite extension for wider reach, and an anti splash grid that can hold used filters for draining.

70
LITRES

COMMON FEATURES

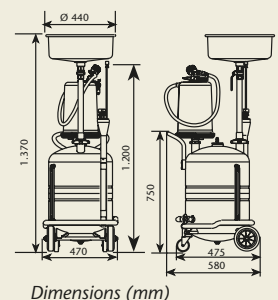

- 70 litres (17 gallons) capacity steel reservoir, with side level gauge.
- Two reinforced casters and two reinforced fixed wheels
- Steel tank with epoxy powder coating.



Combined oil suction and gravity collection units, with transparent chamber. Units with a 10 litres transparent chamber that can be used as a vacuum reservoir and allows an immediate inspection of the extracted waste oil. They can be used remotely once vacuum is created inside the steel reservoir. Discharge through a 1,5 m discharge hose pressurizing the unit. Includes safety valve to avoid over pressurization.

372 000, 100 litres combined oil suction and gravity collection unit, with transparent chamber

373 000, 70 litres combined oil suction and gravity collection unit, with transparent chamber

Combined oil suction and gravity collection units. They can be used remotely once vacuum is created inside the steel reservoir. Discharge is done through a 1,5 m discharge hose pressurizing the unit. Includes safety valve to avoid over pressurization.

372 500, 100 litres combined oil suction and gravity collection unit

373 500, 70 litres combined oil suction and gravity collection unit



Oil suction collection units with transparent chamber. Units include a 10 litres transparent chamber that can be used as a vacuum reservoir and allows an immediate inspection of the extracted waste oil. They can be used remotely once vacuum is created inside the steel reservoir. Discharge through a 1,5 m discharge hose pressurizing the unit. Includes safety valve to avoid over pressurization.

372 100, 100 litres waste oil suction collection unit with transparent chamber

373 100, 70 litres waste oil suction collection unit with transparent chamber

Oil suction collection units. They can be used remotely once vacuum is created inside their steel reservoir. Discharge through a 1,5 m discharge hose pressurizing the unit (except model 371 600). Includes safety valve to avoid over pressurization.

372 600, 100 litres waste oil suction collection unit

373 600, 70 litres waste oil suction collection unit

371 600, 24 litres waste oil suction collection unit

DRAIN UNITS - GRAVITY COLLECTION



Gravity collection with pressure discharge. Discharge is done through a 1,5 m hose pressurizing the unit at 0,5 bar (3.5 psi). Includes a safety valve to avoid over pressurization.

372 400, 100 litres gravity waste oil drainer. Pressure discharge

373 400, 70 litres gravity waste oil drainer. Pressure discharge

Gravity collection with pump discharge. Discharge is done through a 1:1 pressure ratio pneumatic piston pump attached to the back of the unit reservoir and 1,5 m hose with a hydraulic type coupler.

372 200, 100 litres gravity waste oil drainer. Pump discharge

373 200, 70 litres gravity waste oil drainer. Pump discharge

Gravity collection with remote pump discharge. Discharge is done connecting the unit to a wall mounted discharge pump kit through a hydraulic coupler located at the bottom of the reservoir.

372 300, 100 litres gravity waste oil drainer. Remote pump discharge

373 300, 70 litres gravity waste oil drainer. Remote pump discharge

USED FLUID COLLECTION UNITS - SPECIALTY DRAINERS



Low level mobile drainers for gravity collection of waste oil and used automotive fluids such as antifreeze solutions. Recommended to use when a hoist or a service pit is not available. Gravity discharge through a drain valve or using an evacuation pump kit (PN 559 100) through a dry break hydraulic connector (PN 950 352) (not included).

435 000 Low level mobile drainer, 20 litres

20 litres (5.2 gallons) unit for use with passenger cars and small vans.

436 000 Low level mobile drainer, 95 litres

95 litres (25 gallons) unit for use with passenger cars, vans, tractors, commercial vehicles, etc.

436 100 Anti-freeze recovery unit

Low level-waste oil drainer 436 000 equipped with a DF50 diaphragm pump. Allows draining the antifreeze when a pit or lift is not available. Thanks to the diaphragm pump and the delivery gun is possible to reuse the antifreeze.

439 100 Pit rolling drainer, 95 Litres

Rolling drainer for being installed between pit rails with minimum / maximum width of 1.040 / 1.450 mm. 95 litres (25 gallons) capacity. Unit includes anti splash grid, four vertical and four horizontal rollers for easy rolling and an 1-1/4" outlet with ball valve. The unit allows the connection of a hydraulic connector for discharging the unit once full with a discharge pump kit.

WASTE OIL EVACUATION PUMP KITS

559 100

WASTE OIL EVACUATION PUMP KIT



559 100 Waste oil evacuation pump kit

DF100 double diaphragm pump kit for discharging waste oil drainers through a hydraulic coupler. Kit includes: DF100 double diaphragm pump with wall bracket, 1,5 m air connection hose with quick coupler and connector, 1,5 m discharge hose and 1,5 m transparent suction hose with hydraulic connector 950 352.

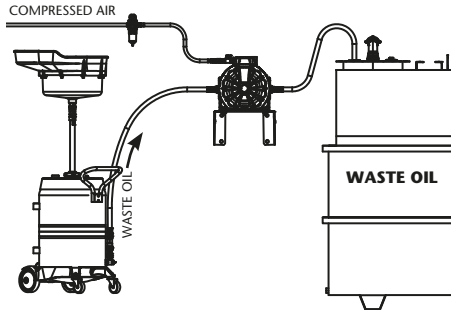

Recommended accessories:

- 950 303**, 3/4" BSP (FF) shut off valve.
- 950 353**, 3/4" hydraulic coupler.

240 500 Air line filter and pressure regulator

- 239 001**, 3/8" BSPT (M) x 1/4" BSPT (M) adaptor.
- 945 551**, 3/4" BSP (MM) adaptor.

559 110

WASTE OIL DRAIN AND EVACUATION KIT FOR CONSTRUCTION AND MINING VEHICLES



559 110 Waste oil drain and evacuation kit for construction and mining vehicles

15 m x 1" high volume hose reel with its inlet hose connected to a DF100 double diaphragm pump. The kit is used for clean, fast and efficient waste oil evacuation from large construction and mining vehicles when connected to the vehicle's engine with a connector compatible with the one at the vehicle drain plug (camlock or hydraulic coupler).

The kit includes a 15 m x 1" hose reel, a DF100 aluminium diaphragm pump, 1.5 x 3/4" discharge hose and 1,5 m air connection hose with quick coupler and connector.

Recommended accessories:

- 950 303**, 3/4" BSP (FF) shut off valve.
- 950 353**, 3/4" hydraulic coupler.
- 240 500**, air line filter and pressure regulator.
- 239 001**, 3/8" BSPT (M) x 1/4" BSPT (M) adaptor.
- 945 551**, 3/4" BSP (MM) adaptor.

379 710

EVACUMASTER WASTE OIL SUCTION UNIT



Single point waste oil suction unit for collecting waste oil directly from the vehicle's engine using a suction cane inserted into the engine oil dip stick tube. The unit is installed alongside the service bay and provides the cleanest method for waste oil collection.

Direct from engine to storage tank eliminates operator contact with waste oil and eliminates splashes and spills of waste oil. It also eliminates the use of mobile units and removes all leaking drain plugs issues.

An air operated pump, specially designed for suction applications, extracts the waste oil and pumps it to a remote storage tank. The unit can be used together with a waste oil hose reel (506503 or 506703) for extended reach.

The unit includes a special piston pump for waste oil suction, on/off valve, air filter with pressure regulator, vacuum gauge for monitoring the unit performance, extra large capacity suction filter, 3 m suction hose and complete kit of suction canes and adaptors.

379 711 Wall mounted waste oil suction unit

379 710 Pedestal mounted waste oil suction unit

TYPICAL INSTALLATION

Maximum installation distances:

- A:** Maximum distance 12 m, including hose reel hose fully extended.
- B:** Maximum suction height, 2,5 m.
- C:** Maximum height between pump outlet and engine oil sump level, 1 m.

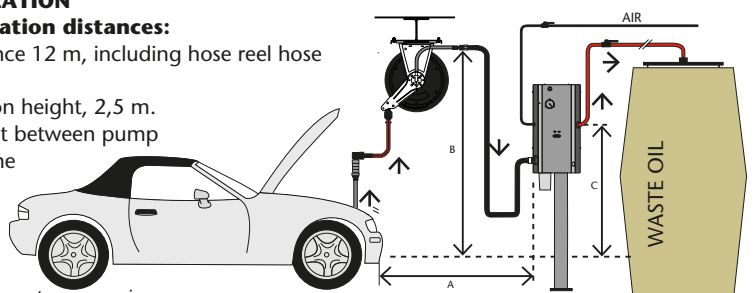

See next page for Evacumaster accessories

372 003



WASTE OIL SUCTION ACCESSORIES

372 003 Transparent chamber kit

10 l transparent chamber, mounts on 70 and 100 litres waste oil suction units. Completes with vacuum pump, vacuum gauge and 2 m suction hose with rubber grip and connector for Mercedes Benz vehicles.

737 967 Suction hose kit

2 m transparent suction hose with rubber grip, shut-off valve and connector for Mercedes Benz vehicles.

372 002 - 743 305



WASTE OIL COLLECTION BOWLS

372 002. Collection bowl for 100 litres waste oil receivers

Includes 20 l metal bowl, oversized extension and antispash grid, tube, shut-off valve, swivel and adapter for fixing the tube to receivers.

373 002 Collection bowl for 100 litres waste oil receivers

Includes 20 l metal bowl, tube, shut-off valve, swivel and adapter for fixing the tube to receivers.

743 305, 20 litres collection bowl

20 l metal bowl with tube and 2" bung adaptor for fixing to an empty drum.

506 503 - 507 503



WASTE OIL SUCTION HOSE REELS

For use with EVACUMASTER units.

506 503 Aluminium single arm waste oil hose reel

Includes 6 m x 5/8" suction hose and 0,8 m x 5/8" connection hose.

507 503 Individually enclosed waste oil hose reel

Includes 6 m x 5/8" suction hose and 0,8 m x 5/8" connection hose.

SUCTION CANES AND ADAPTORS

INDIVIDUAL WANDS AND ADAPTORS

Part No.	Type	Description OD x ID x Length
737 952	Flex	6 x 4 x 700 mm
737 953	Flex	8 x 6 x 700 mm
737 954	Rigid Copper	5 x 4 x 700 mm
737 955	Rigid Copper	6 x 5 x 700 mm
737 949	Flex	7 x 5 x 1.000 mm
737 958	Flex	6 x 4 x 1.200 mm
737 959	Flex	8 x 6 x 1.200 mm
737 946	Flex	8 x 6 x 1.700 mm
737 947	Adaptor	AUDI, VOLKSWAGEN GROUP
737 948	Adaptor	PSA GROUP



737 950 Suction canes and adaptors set

Includes canes Part No. 737 952, 737 953, 737 955 and adaptors Part No. 737 947 and 737 948.

737 972 Suction canes and adaptors set with canes holder

Canes and adaptors set Part No. 737 950 with a suction canes holder.

DRUM TROLLEYS



432 000

431 000

432 000, 185 kg / 200 litres drum trolley

431 000, 50 kg drum trolley

HYDRAULIC CONNECTORS AND COUPLERS

950 352, 3/4" BSP (F) hydraulic connectors.

950 353, 3/4" BSP (F) hydraulic coupler.

945 551, 3/4" BSP (MM) connection adaptor

945 513, 1-1/4" BSP (M) - 3/4" (M) connection adaptor.



DC DIESEL PUMPS AND KITS - POLUX SERIES	98
AC DIESEL PUMPS AND KITS - POLARIS SERIES	99
DIESEL PUMP ACCESSORIES	101
AdBlue®/DEF PUMPS AND KITS - SOLURA SERIES	102
AdBlue®/DEF PUMP ACCESSORIES	103
OIL PUMPS AND KITS WITH ELECTRIC MOTOR - FLOWSTAR SERIES	104



DC DIESEL PUMPS AND KITS - POLUX SERIES

684 530 - 684 451

12 & 24 V DC ROTARY VANE PUMPS - POLUX SERIES



12 and 24 VDC rotary vane pumps for diesel

Self priming pumps with self-adjustable vanes. Pump body made of cast-iron with rustproof treatment, rotor of sintered steel and vanes of acetyl resin. The pump includes a by-pass valve and a built in filter with easy access for cleaning. The pump can be mounted vertically or horizontally, has a carrying handle and 2 m cable with crocodile clamps.

Inlet / outlet connection: 1" BSP (F) or flange coupling.

Maximum suction lift: 2,5 m.

Electric DC motor with IP-55 protection, allows intermittent operation duty with maximum cycles of 30 minutes.

On/off switch and fuse.

PART No.	SUPPLY	CURRENT	POWER	PRESSURE	FLOW RATE
684 530	12 VDC	22 A	140 W	0,8 bar	40 l/min
684 451	12 VDC	38 A	220 W	0,8 bar	60 l/min
684 531	24 VDC	13 A	160 W	0,8 bar	43 l/min
684 450	24 VDC	25 A	240 W	0,8 bar	65 l/min

684 512 - 684 514

12 V PUMP - POLUX SERIES DIESEL TRANSFER KITS



Portable transfer kit with 12 VDC Polux Series pump, delivery hose, nozzle, meter, fittings and suction kit depending on the model.

Order suction accessories separately when not included.

PART No.	PUMP	OUTLET HOSE	NOZZLE	SUCTION KIT
684 512	684 530	4 m (689 024)	Standard (361 000)	-
684 951	684 530	4 m (689 024)	Standard (361 000)	2 m (689 030)
684 514	684 530	4 m (689 024)	Standard + Meter (361 000) + (366 976)	2 m (689 030)
684 461	684 451	4 m (689 021)	Automatic (688 300)	-
684 465	684 451	4 m (689 021)	Automatic + Meter (688 300) + (366 976)	2 m (689 030)

684 460 - 684 464

24 V PUMP - POLUX SERIES DIESEL TRANSFER KITS



Portable transfer kit with 24 VDC Polux Series pump, delivery hose, nozzle, meter, fittings and suction kit depending on the model.

Order suction accessories separately when not included.

PART No.	PUMP	OUTLET HOSE	NOZZLE	SUCTION KIT
684 524	684 531	4 m (689 024)	Standard (361 000)	-
684 526	684 531	4 m (689 024)	Standard (361 000)	2 m (689 030)
684 527	684 531	4 m (689 024)	Standard + Meter (361 000) + (366 976)	2 m (689 030)
684 460	684 450	4 m (689 021)	Automatic (688 300)	-
684 464	684 450	4 m (689 021)	Automatic + Meter (688 300) + (366 976)	2 m - (689 030)

AC DIESEL PUMPS AND KITS - POLARIS SERIES

685 720 - 685 722

230 V - 50 HZ AC ROTARY VANE PUMPS - POLARIS SERIES



230 VAC - 50 Hz rotary vane pumps for diesel

Self priming pumps with self-adjustable vanes. Pump body made of cast-iron with rustproof treatment, rotor of sintered steel and vanes of acetyl resin. The pump includes a by-pass valve and a built in filter with easy access for cleaning. The pump can be mounted vertically or horizontally and has 1,8 m cable with plug.

Inlet/outlet connection: 1" BSP (F) or flange coupling

Maximum suction lift: 2,5 m

Electric DC motor with IP-55 protection, allows continuous operation duty.

On / off switch and fuse.

PART No.	SUPPLY	CURRENT	POWER	PRESSURE	FLOW RATE
685 720	230 VAC	2,2 A	370 W	1,7 bar	50 l/min
685 721	230 VAC	3 A	500 W	1,7 bar	70 l/min
685 722*	230 VAC	4,6 A	750 W	1,7 bar	95 l/min

* Does not include built in filter.

685 741 - 685 742

230 V PUMP - POLARIS SERIES DIESEL TRANSFER KITS



230 VAC Polaris Series pump kits, include delivery hose and nozzle, fittings and suction kit depending on the model.

Order suction accessories separately when not included.

PART No.	PUMP	OUTLET HOSE	NOZZLE	SUCTION KIT
685 741	685 720	4 m (689 024)	Standard (361 000)	-
685 974	685 720	4 m (689 024)	Standard (361 000)	2 m (689 030)
685 742	685 720	4 m (689 021)	Automatic (688 300)	-
685 743	685 720	4 m (689 021)	Automatic (688 300)	2 m (689 030)
685 771	685 721	4 m (689 024)	Standard (361 000)	-
685 772	685 721	4 m (689 021)	Automatic (688 300)	-

685 750 - 685 752

230 V - POLARIS SERIES DIESEL TRANSFER KITS WITH METER



230 VAC Polaris Series pump, kit with mechanical meter (PN 680 300), delivery hose, fittings, nozzle and suction kit depending on the model. Meter valid for non commercial applications only.

Order suction accessories separately when not included.

PART No.	PUMP	OUTLET HOSE	NOZZLE	SUCTION KIT
685 750	685 720	4 m (689 024)	Standard (361 000)	-
685 752	685 720	4 m (689 021)	Automatic (688 300)	-
685 754	685 720	4 m (689 021)	Automatic (688 300)	689 036
685 751	685 721	4 m (689 024)	Standard (361 000)	-
685 753	685 721	4 m (689 021)	Automatic (688 300)	-
685 755	685 721	4 m (689 021)	Automatic (688 300)	689 036

AC DIESEL PUMP KITS - POLARIS SERIES

685 716 - 685 718

WALL MOUNTED TRANSFER 230 V PUMP KITS - POLARIS SERIES



50 or 70 l/min Polaris Series pump on a bracket for wall or tank mounting. The kit includes a 230 V - 50 Hz diesel pump with on/off switch and 1,8 m cable with plug, wall mounting bracket, 4 m delivery hose, nozzle and a three digit meter (PN 680 300) flange mounted to the pump and with a 90° swivelling elbow outlet. Fluid inlet connection 1" BSP (F).

Order suction accessory separately when not included.

Meter valid for non commercial applications only.

PART No.	PUMP	OUTLET HOSE	NOZZLE	METER	SUCTION KIT
685 710	685 720	4 m (689 024)	Standard (361 000)	680 300	-
685 717	685 720	4 m (689 021)	Automatic (688 300)	680 300	-
685 708	685 720	4 m (689 021)	Automatic (688 300)	680 300	689 037
685 713	685 721	4 m (689 024)	Standard (361 000)	680 300	-
685 716	685 721	4 m (689 021)	Automatic (688 300)	680 300	-
685 709	685 721	4 m (689 021)	Automatic (688 300)	680 300	689 037
WAL MOUNTED KITS WITH FILTER (689 090)					
685 719	685 720	4 m (689 021)	Automatic (688 300)	680 300 + filter	-
685 718	685 721	4 m (689 021)	Automatic (688 300)	680 300 + filter	-

685 715

WALL MOUNTED 230 V PUMP CABINETS - POLARIS SERIES



50 or 70 l/min Polaris Series pump in a cabinet for wall or tank mounting. The unit includes a 230 V - 50 Hz diesel pump with 1,8 m cable with plug, cabinet with nozzle holder with automatic on/ off switch, 4 m delivery hose, automatic nozzle and a three digit meter, flange mounted to the pump and with a 90° swivelling elbow outlet.

Fluid inlet connection 1" BSP (F). Order suction accessories separately.

Meter valid for non commercial applications only.

PART No.	PUMP	OUTLET HOSE	NOZZLE	METER
685 712	680 720	4 m (689 021)	Automatic (688 300)	680 300
685 715	680 721	4 m (689 021)	Automatic (688 300)	680 300

685 715

230 V PUMP LOCKABLE CABINETS - POLARIS SERIES



50 or 70 l/min Polaris Series pump in a cabinet with safety lock for wall or tank mounting. The unit includes a 230 V - 50 Hz diesel pump with 1,8 m cable with plug cabinet with nozzle holder with automatic on/ off switch, 4 m delivery hose, automatic nozzle and a three digit meter, flange mounted to the pump and with a 90° swivelling elbow outlet.

Fluid inlet connection 1" BSP (F). Order suction accessories separately.

Meter valid for non commercial applications only.

PART No.	PUMP	OUTLET HOSE	NOZZLE	METER
685 777	680 720	4 m (689 021)	Automatic (688 300)	680 300
685 778	680 721	4 m (689 021)	Automatic (688 300)	680 300



DIESEL METERS

Nutating-disk meter for diesel with mechanical register. Very low pressure drop; it can be used for gravity fed applications. Resettable partial reading up to 999,9 liters and permanent 6 digit totaliser. 1" BSP (F) inlet and outlet, both with flange for optional flange mounting. The meter allows to orientate the inlet and outlet in four different positions. Maximum working pressure: 10 bar. Flow range: 20 to 100 l/minute. Precision after calibration: ± 1%. Meter valid for non commercial applications only.

- 680 300 Diesel meter with mechanical 3 digit register**
- 680 301 Diesel meter with mechanical 4 digit register**
- 689 044 Swivel elbow for meter outlet 1" BSP (MF)**

DIESEL NOZZLES

- 361 000 Aluminium manual nozzle. Fluid inlet: 1" BSP (F) - 100 l/min.**
- 689 910 Thermoplastic manual nozzle. Fluid inlet: 1" BSP (F) - 80 l/min.**

- 688 300 Aluminium automatic nozzle. Fluid inlet: 1" BSP (F) - 60 l/min.**
- 688 001 Aluminium automatic nozzle. Fluid inlet: 1" BSP (F) - 80 l/min.**
- 688 100 Aluminium automatic nozzle. Fluid inlet: 1" BSP (F) - 120 l/min.**
- 364 030 Aluminium inlet swivel. 1" BSP (MF) (included in automatic nozzles).**

DIESEL FILTERS

When fitted at the pump outlet they eliminate dirt up to 30 microns and the water contained in the diesel.

- 689 090, 110 l/min diesel filter, 1" BSP (F).**
- 689 098, 65 l/min diesel filter, 1" BSP (F).**
- 689 091 Replacemente cartridge**
For filter 689 090
- 689 099 Replacemente cartridge**
For filter 689 098

HOSES FOR DIESEL

Rubber hose with metal swagged 1" BSP (M) fittings.



PART No.	HOSE LENGTH AND Ø
689 021	4 m x Ø 19 mm
689 022	4 m x Ø 25 mm
689 023	6 m x Ø 19 mm

PUMP BRACKETS

- 689 052 Pump wall bracket**
- 756 200 Bracket with handle**
- 360 137 Universal bracket for 205 litres drum and IBCs**



SUCTION TUBES

Telescopic suction tubes for connecting directly to the pump inlet. 1" BSP (M) connection, 2" (M) bung adaptor and foot valve with filter, (PN 689 042).

- 689 035 For drums or tanks with a maximum height of 1m**
- 689 036 For tanks with a maximum height between 1 and 1,75 m**
- 689 037 Suction assembly. Includes 2 m x Ø 25 mm hose, shut off valve and telescopic suction tube 689 036**

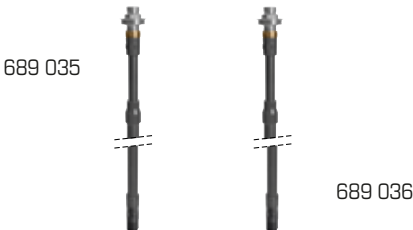

CONNECTION ADAPTORS FOR HOSES

- 689 042 Foot valve with filter for suction tube, 1" BSP (F)**
- 689 015 Brass foot valve with filter for suction tube, 1" BSP (F)**
- 689 041 Suction filter for hose, Ø 25 mm**
- 689 016 Brass suction filter for hose, 1" BSP (F)**
- 689 040 «Y» strainer, 1" BSP (F)**
- 689 019 Brass «Y» strainer, 1" BSP (F)**

- 689 047 Hose barb adaptor Ø 19 mm with clamps, 1" BSP (M)**
- 689 048 Hose barb adaptor Ø 25 mm with clamps, 1" BSP (M)**

- 689 017 Brass hose barb adaptor Ø 19 mm with clamps, 1" BSP (M)**
- 689 018 Brass hose barb adaptor Ø 25 mm with clamps, 1" BSP (M)**

- 689 053 Pump, drum and suction kit connection adaptor, 2 x 1" BSP (M) / 2" BSP (M)**



689 030



SUCTION HOSES

Transparent PVC spring reinforced hoses. Suction hoses include swaged metal 1" BSP (M) fittings and foot valve.

- 689 030, 2 m x Ø 25 mm**
- 689 031, 4 m x Ø 25mm**

560 230 - 560 224

ELECTRIC PUMPS FOR AdBlue®/DEF – SOLURA SERIES



12 and 24 VDC and 230 V 50 Hz AC multi-diaphragm pumps with no mechanical seals designed for dispensing AdBlue®/DEF (Urea Solutions). Pumps are self priming and have a by-pass valve. Electric motors have IP55 protection and include on/off switch, fuse and 2 m cable with crocodile clamps (DC pumps) or plug (AC pump).

Inlet/outlet connection: 1" BSP (M).

Maximum suction lift: 1,8 m.

Maximum delivery pressure: 1,6 bar.

Maximum delivery: up to 32 l/min.

PART No.	POWER SUPPLY	ELECTRIC MOTOR POWER	MAXIMUM DELIVERY
560 230	230 V 50 Hz AC	400 W	30 l/min
560 224	24 VDC	310 W	32 l/min
560 212	12 VDC	260 W	32 l/min

AdBlue®/DEF PUMP KITS

All kits include 4 m x 19 mm EPDM delivery hose and the accessories listed in the following table:



560 304



560 300



560 310

PART No.	POWER SUPPLY	APPLICATION	PUMP	BRACKET	NOZZLE	METER	SUCTION ACCESSORIES
560 301	230 VAC	IBCs and drums	560 230	360 137	361 001.370 manual		1 m hose and CSC connector
560 302	230 VAC	IBCs and drums	560 230	360 137	361 001.370 manual	366 760	1 m hose and CSC connector
560 303	230 VAC	IBCs and drums	560 230	360 137	569 000 automatic		1 m hose and CSC connector
560 304	230 VAC	IBCs and drums	560 230	360 137	569 000 automatic	366 760	1 m hose and CSC connector
560 300	230 VAC	IBCs and drums	560 230		361 001.370 manual		2,5 m hose and foot valve
560 310	12 VDC	IBCs and drums	560 212		361 001.370 manual		2,5 m hose and foot valve
560 320	24 VDC	IBCs and drums	560 224		361 001.370 manual		2,5 m hose and foot valve

366 010

AdBlue®/DEF ELECTRONIC LINE METERS



366 010 AdBlue®/DEF oval gear meter

Oval gear meter manufactured in PVC, stainless steel and acetal for AdBlue®/DEF. Digital display, works with two AAA alkaline batteries. Inlet/outlet thread 1/2" BSP (F). Flow rate: 1-50 l/min.

366 760 AdBlue®/DEF meter, 1" BSP (MM)

Digital line meters provided with metering chamber with turbine system, electronic display, reset button, partial metering function (99.999 l), resettable totalizer (999.999), calibration function. Flow rate: 8 - 110 l/min. Max. pressure: 10 bar. Precision: +/- 1%. Power supply: 2 x 1,5 V batteries.

366 976 AdBlue®/DEF meter with a stainless steel female adaptor, 1" BSP (FM)

366 761 AdBlue®/DEF meter with a 2 stainless steel female adaptors, 1" BSP (FF)

689 055 Polypropylene thread adaptor, 1" BSP (FF)

945 708 Stainless steel thread adaptor, 1" BSP (FF)

569 000

AdBlue®/DEF NOZZLES



AdBlue®/DEF nozzles with stainless steel and thermoplastic versions available. Depending on the model they can be manual or automatic, with spike or thread connection.

361 003.370 Manual (thermoplastic), 90 l/min, 1" BSP (F) inlet thread

361 002.370 Manual (thermoplastic), 90 l/min, Ø 25 mm inlet thread

361 001.370 Manual (thermoplastic), 90 l/min, Ø 19 mm inlet thread

569 000 Automatic (stainless steel), 45 l/min, Ø 19 mm inlet thread

569 001 Automatic (stainless steel/polypropylene), 45 l/min, Ø 19 mm inlet thread

930 507

AdBlue®/DEF HOSES

EPDM HOSES

Service EPDM hoses for AdBlue®/DEF transferring or suction, sold in bulk (minimum 1 m).

930 507, Ø 19 mm / 1 m EPDM hose

930 505, Ø 13 mm / 1 m EPDM hose



PVC HOSES

Transparent suction hoses made of reinforced PVC for AdBlue®/DEF transferring.

689 030, 2 m x PVC suction hose Ø 25 mm

With swaged terminals and foot valve 689 042, 1" BSP (M).

689 031, 4 m x PVC suction hose Ø 25 mm

With swaged terminals and foot valve 689 042, 1" BSP (M).

932 025, 1 m hose PVC Ø 25 mm in bulk

(Minimum 1 m).

689 041



560 901

AdBlue®/DEF ACCESSORIES

689 042 Polypropylene foot valve with filter. 1" BSP (F)

560 903 Polypropylene foot valve. 1" BSP (F)

689 041 Polypropylene filter for suction hose, Ø 25 mm hose barb connection

689 047 Polypropylene hose tail connection kits, Ø 19 mm. 1" BSP (M), with connection clamps

689 048 Polypropylene hose tail connection kits, Ø 25 mm. 1" BSP (M), with connection clamps

560 901 CSC quick coupling, Ø 19 mm hose barb connection

560 902 Suction tube for CSC connection. With 2" BSP (M) connection

560 906 Suction tube for CSC connection. With 2" TRISURE connection

560 904 1" BSP (F) check valve

360 137



360 137 Universal pump bracket

Allows fixing a pump onto a 205 l drum or to a 1000 IBC. With carrying handle and drip pocket.

OIL PUMPS WITH ELECTRIC MOTOR - FLOWSTAR SERIES

561 012

OIL PUMPS WITH 12 AND 24 VDC ELECTRIC MOTOR - FLOWSTAR SERIES



External gear pumps with 12 and 24 V DC motors with IP55 protection, on/off switch, fuse and 2 m cable with crocodile clamps. Pump can work in intermittent duty cycles of 30 minutes and has built in by-pass valve.

Inlet connection: 3/4" BSP (F).

Outlet connection: 1/2" BSP (F).

Maximum suction lift: 2,5 m.

PART NO.	POWER SUPPLY	ELECTRIC MOTOR POWER	MAXIMUM PRESSURE	MAXIMUM DELIVERY
561 012	12 VDC	200 W	11,5 bar	5,2 l/min
561 024	24 VDC	200 W	12,5 bar	5,6 l/min

561 300 - 561 210

OIL PUMPS WITH 230 VAC AND 380 VAC MOTORS - FLOWSTAR SERIES

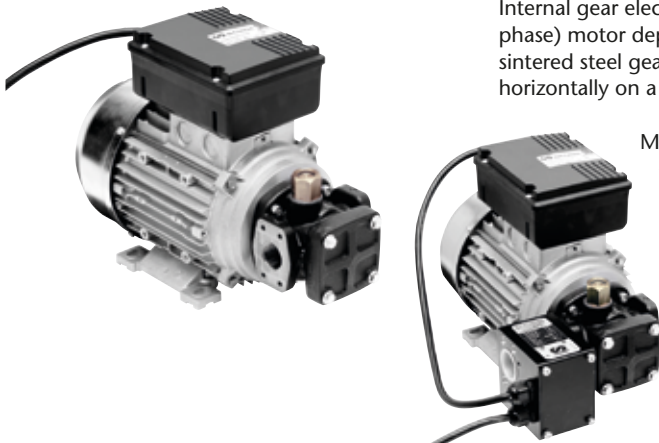

Internal gear electric pumps for lubricants. 230 V - 50 Hz (single phase) or 380 V - 50 Hz (three phase) motor depending on model, IP-55 protection and on/off switch. Cast iron pump body, sintered steel gears and by-pass valve. Motor with mounting feet, the pump can be mounted horizontally on a flat surface or vertically to a wall.

Models with electronic pressure switch start automatically whenever a pressure drop in the distribution line occurs (i.e. when a delivery gun is opened) and stops once pressure is built again in the line (i.e. when a delivery gun is closed).

PART No.	POWER SUPPLY	ELECTRIC MOTOR POWER	MAXIMUM PRESSURE	MAXIMUM DELIVERY	ELECTRONIC PRESSURE SWITCH
561 100	230 V - 50 Hz	600 W	10 bar	10 l/min	NO
561 101	400 V - 50 Hz	600 W	10 bar	10 l/min	NO
561 110	230 V - 50 Hz	600 W	10 bar	10 l/min	YES
561 200	230 V - 50 Hz	780 W	15 bar	13 l/min	NO
561 201	400 V - 50 Hz	780 W	15 bar	13 l/min	NO
561 210	230 V - 50 Hz	780 W	15 bar	13 l/min	YES
561 300	230 V - 50 Hz	780 W	24 bar	11 l/min	NO
561 301	400 V - 50 Hz	780 W	24 bar	11 l/min	NO
561 310	230 V - 50 Hz	780 W	24 bar	11 l/min	YES

561 610

HIGH PERFORMANCE OIL PUMPS WITH ELECTRIC MOTOR - FLOWSTAR SERIES HV

High performance external gear pumps directly coupled to an electric motor with IP 55 protection for the transfer or distribution of large volumes of lubricants. Pump gears are manufactured in steel and pump body is manufactured in cast iron. All pumps include adjustable by-pass valve.



PART No.	POWER SUPPLY	ELECTRIC MOTOR POWER	MAXIMUM PRESSURE	MAXIMUM DELIVERY
561 615	230 V - 50 Hz	750 W	8 bar	25 l/min
561 614	230 V - 50 Hz	1.500 W	8 bar	50 l/min
561 611	230 V - 50 Hz	2.000 W	8 bar	70 l/min
561 613	400 V - 50 Hz	1.500 W	10 bar	50 l/min
561 610	400 V - 50 Hz	1.500 W	9,5 bar	70 l/min

561 014 - 561 013

OIL PUMP PORTABLE KITS - FLOWSTAR SERIES



PART No.	POWER SUPPLY	PUMP	OUTLET HOSE	DELIVERY GUN	SUCTION ACCESSORIES	OTHER ACCESSORIES
562 000	230 VAC	561 100	3 m (362 103)	Metered control gun 365 535	3 m with foot valve 367 012	Bracket 756 012
562 010	230 VAC	561300	3 m (362 103)	Metered control gun 365 535	3 m with foot valve 367 012	Bracket 756 012
561 014	12 VDC	561 012	3 m (362 103)	Control gun 363 115	3 m with foot valve 367 012	-
561 013	12 VDC	561 012	3 m (362 103)	Metered control gun 365 535	3 m with foot valve 367 012	-
561 026	24 VDC	561 024	3 m (362 103)	Control gun 363 115	3 m with foot valve 367 012	-
561 025	24 VDC	561 024	3 m (362 103)	Metered control gun 365 535	3 m with foot valve 367 012	-

562 100

MOBILE OIL DISPENSER FOR 205 L DRUMS WITH ELECTRIC 230 V PUMP - FLOWSTAR SERIES

Mobile oil dispenser with Flowstar Series electric pump. Includes connection accessories, hose end meter and trolley for 205 litre drums.



PART No.	PUMP	OUTLET HOSE	SERVICE GUN	SUCTION KIT	OTHER ACCESSORIES
562 100	561 100	3 m (362 103)	Metered control valve (365 535)	3 m (367 012)	Trolley (432 000) + (360 134)

GREASE NIPPLES	108
GREASE CONNECTORS	110
LEVER ACTION GREASE PUMPS	111
MANUAL HAND HELD GREASE PUMPS	112
AIR OPERATED AND BATTERY HAND HELD GREASE PUMPS, FILLER PUMPS AND FITTINGS	113
GREASE COMPRESSORS AND BUCKET PUMPS	114
DRUM PUMPS FOR OIL	115
DRUM PUMPS FOR VARIOUS FLUIDS	116
FUNNELS, MEASURES, GRAVITY COCKS, JERRY CANS AND OIL SUCTION PUMPS	117
AIR TREATMENT UNITS (FRLS)	118
AIR COUPLERS AND CONNECTION ADAPTORS FOR COMPRESSED AIR	119





550 bar



DIN 71412
Form A

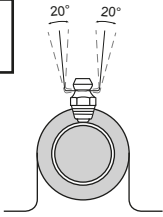
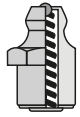

MT 503



DIN 71412
Form B
45°

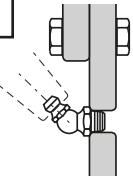

MT 506



DIN 71412
Form C
90°

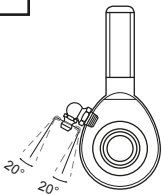

MT 508



MT 505



HYDRAULIC GREASE NIPPLES

MT 503 STRAIGHT	MT 506 45° ANGLED	MT 508 90° ANGLED	THREAD	PITCH
011 060	013 060	015 060	Metric	M 6 x 1,00
011 100	013 100	015 100	Metric	M 7 x 1,00
011 140	013 140	015 140	Metric	M 8 x 1,00
011 160	013 160	015 160	Metric	M 8 x 1,25
011 180	013 180	015 180	Metric	M 9 x 1,00
011 220	013 220	015 220	Metric	M 10 x 1,00
011 240	013 240	015 240	Metric	M 10 x 1,25
011 260	013 260	015 260	Metric	M 10 x 1,50
011 280	013 280	015 280	Metric	M 12 x 1,00
011 300	013 300	015 300	Metric	M 12 x 1,25
011 320	013 320	015 320	Metric	M 12 x 1,50
011 340	013 340	015 340	Metric	M 12 x 1,75
011 600	013 600	015 600	BSP	1/8"
011 620	013 620	015 620	BSP	1/4"
011 500	013 500	015 500	SAE (UNF)	1/4" (x 28)
011 520	013 520	015 520	SAE (UNF)	5/16" (x 18)
011 540	013 540	015 540	SAE (UNF)	3/8" (x 16)
011 700	013 700	015 700	Whitworth	1/4"
011 720	013 720	015 720	Whitworth	5/16"
011 740	013 740	015 740	Whitworth	3/8"
011 900	013 900	015 900	NPT	1/8"
011 910	013 910	015 910	NPT	1/4"
011 930	N/A	N/A	No thread	Ø 6 mm
011 940	N/A	N/A	No thread	Ø 8 mm
011 950	N/A	N/A	No thread	Ø 10 mm

LONG HYDRAULIC NIPPLES

MT 505

012 020	Long hydraulic nipple, M 6 x 1,00
012 220	Long hydraulic nipple, 1/4" SAE

HYDRAULIC GREASE NIPPLES ASSORTMENT

050 001	Assortment of 140 hydraulic grease nipples. Includes straight, 45° and 90° hydraulic nipples with the most popular threads.			
TYPE	M 6 X 1,00	M 8 X 1,25	M 10 X 1,00	1/8" BSP
STRAIGHT	25 units	25 units	15 units	15 units
45° ANGLED	10 units	10 units	5 units	5 units
90° ANGLED	10 units	10 units	5 units	5 units

BLISTER PACKED HYDRAULIC NIPPLES

051 060	Includes 20 units of M 6 x 1,00 straight nipples
051 160	Includes 20 units of M 8 x 1,25 straight nipples
051 220	Includes 10 units of M 10 x 1,00 straight nipples
051 260	Includes 10 units of M 10 x 1,50 straight nipples
051 600	Includes 10 units of 1/8" BSP straight nipples
052 060	Includes 10 units of M 6 x 1,00, 5 units 45° and 5 units 90° angled nipples
052 160	Includes 10 units of M 8 x 1,00, 5 units 45° and 5 units 90° angled nipples
052 220	Includes 10 units of M 10 x 1,00, 5 units 45° and 5 units 90° angled nipples
052 260	Includes 10 units of M 10 x 1,50, 5 units 45° and 5 units 90° angled nipples
052 600	Includes 10 units 1/8" BSP, 5 units 45° and 5 units 90° angled nipples



150 bar

031 950



400 bar

032 260



400 bar

MT 150



400 bar

MT 153

MT 157



MT 156

MT 930



FLUSH TYPE DRIVE OIL NIPPLES

PART No.	DIAMETER	
031 939	Ø 6 mm	
031 949	Ø 8 mm	
031 950	Ø 10 mm	
031 960	Ø 12 mm	

PART No.	THREAD	PITCH
032 060	Metric	M 6 x 1,00
032 160	Metric	M 8 x 1,20
032 220	Metric	M 10 x 1,00
032 260	Metric	M 10 x 1,50
032 600	BSP	1/8"
032 620	BSP	1/4"
032 740	Whitworth	3/8"
032 939	No thread	Ø 6 mm
032 949	No thread	Ø 8 mm
032 959	No thread	Ø 10 mm

15 MM HEXAGON HEAD NIPPLES (MT 150)

PART No.	THREAD	PITCH	PART No.	THREAD	PITCH
021 060	Metric	M 6 x 1,00	021 380	Metric	M 14 x 2,00
021 140	Metric	M 8 x 1,00	021 600	BSP	1/8"
021 160	Metric	M 8 x 1,25	021 620	BSP	1/4"
021 220	Metric	M 10 x 1,00	021 640	BSP	3/8"
021 240	Metric	M 10 x 1,25	021 500	SAE (UNF)	1/4" (x 28)
021 260	Metric	M 10 x 1,50	021 520	SAE (UNF)	5/16" (x 18)
021 280	Metric	M 12 x 1,00	021 540	SAE (UNF)	3/8" (x 16)
021 300	Metric	M 12 x 1,25	021 700	Whitworth	1/4"
021 320	Metric	M 12 x 1,50	021 720	Whitworth	5/16"
021 340	Metric	M 12 x 1,75	021 740	Whitworth	3/8"

DOUBLE HEXAGON AND ROUND HEAD NIPPLES

PART No.	DIAMETER	THREAD	PITCH	REMARKS
022 160	16 mm	Metric	M 8 x 1,25	MT 153 - double hexagon 15 mm
022 220	16 mm	Metric	M 10 x 1,00	MT 153 - double hexagon 15 mm
022 260	16 mm	Metric	M 10 x 1,50	MT 153 - double hexagon 15 mm
022 600	16 mm	BSP	1/8"	MT 153 - double hexagon 15 mm
022 620	16 mm	BSP	1/4"	MT 153 - double hexagon 15 mm
023 220	16 mm	Metric	M 10 x 1,00	MT 156 - round head
023 600	16 mm	BSP	1/8"	MT 156 - round head
023 620	16 mm	BSP	1/4"	MT 156 - round head
023 640	16 mm	BSP	3/8"	MT 156 - round head
024 620	22 mm	BSP	1/4"	MT 157 - round head
024 640	22 mm	BSP	3/8"	MT 157 - round head
025 620	22 mm	BSP	1/4"	MT 930 - round head
025 640	22 mm	BSP	3/8"	MT 930 - round head

070 000

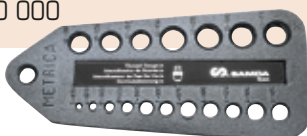

THREAD GAUGES

070 000 Metric thread gauge.
070 001 Whitworth & BSP thread gauge.
070 002 SAE & BSF thread gauge.

GREASE CONNECTORS

GREASE CONNECTORS, NOZZLES AND ACCESSORIES



500 bar

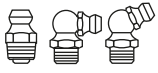

121 011



121 050



121 020



121 000



Hydraulic connectors without check valve

PART No.	Ø	LENGTH	NIPPLE SEAL	JAWS
121 011	15 mm	37 mm	Rubber	4
121 050	18 mm	43 mm	Steel	3 (rever.)



Hydraulic connectors with check valve

Check valve prevents grease drops when the grease pump is not in use.

PART No.	Ø	LENGTH	NIPPLE SEAL	JAWS
121 020	15 mm	37 mm	Rubber	4
121 000	15 mm	37 mm	Rubber	3



150 bar

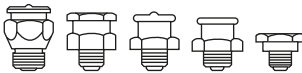

122 011



122 001

GREASE CONNECTORS AND ACCESSORIES

For use with hand operated units on button head nipples. Maximum working pressure 150 bar. Connection thread 1/8" NPT (F).

PART No.	Ø NIPPLE	NIPPLE SEAL
122 001	15/16 mm	Rubber
122 011	22 mm	Rubber

For use with hand operated grease guns only. Connection thread: 1/8" NPT (F). Recommended working pressure 150 bar.



150 bar



123 001



123 011



126 500



124 011



126 200

PART No.	DESCRIPTION	LENGTH	APPLICATION
123 001	Giant cupped nozzle	43 mm	For concave type nipples DIN 3405
123 011	Grease cupped nozzles	14 mm	For concave type nipples DIN 3405
126 500	Needle nose adaptor	37 mm	For hard to reach greasing points
124 011	Grease zerk nozzle	16,60 mm	For Zerk grease nipples DIN 3402
126 200	Seal off adaptor	49 mm	For lubrication holes, spindles, U joints
126 000	Grease needle nozzle	96 mm	With retractable safety sleeve

OTHER ACCESSORIES

PART No.	DESCRIPTION
126 400	Swivelling nozzle adaptor for use with flexible hoses 1/8" NPT (MF)
128 501	Quick connect adaptor for Ø 18 mm hydraulic connectors

GREASE STEMS - 1/8" NPT (MM)

710 659



710 659 Positionable 45° angled rigid stem with four-jaw connector with check valve (PN 121 011).

710 298



710 214 Angled stem with four-jaw connector (PN 121 011).

710 710 Straight stem with four-jaw connector (PN 121 011).

710 297 Straight stem with cupped nozzle (PN 123 011).

710 298 Straight stem with zerk nozzle (PN 124 011).



400 bar



415 bar



136 021



140 020

GREASE OUTLET HOSES

Single polyester braid reinforced rubber hoses. Max. working pressure: 400 bar. Min. burst pressure: 1.000 bar. 1/8" NPT (MM). For hand operated grease pumps.

Double steel braid reinforced rubber hoses. Max working pressure: 415 bar. Min. burst pressure: 1.650 bar. 1/8" NPT (MM). For hand operated and air powered grease pumps.

PART No. HOSE ONLY	PART No. HOSE WITH GREASE CONNECTOR 121 011	HOSE LENGTH
136 021	137 021	300 mm
136 041	137 041	400 mm
136 051	137 051	500 mm
136 201	137 201	2.000 mm

PART No. HOSE ONLY	PART No. HOSE WITH GREASE CONNECTOR 121 020	HOSE LENGTH
140 020	141 020	300 mm
140 040	141 040	400 mm
140 050	141 050	500 mm
140 100	N/A	1.000 mm
140 200	141 200	2.000 mm
140 400	141 400	4.000 mm

All SAMOA lever action grease pumps have the following features and benefits:

- Very tough, real heavy duty, cast iron head for maximum durability, uniform pressure and flow delivered throughout the pump's entire life.
- Precision machined piston ensures leak free high pressure operation without requiring the use of seals.
- Heavy duty knurled barrel with large pitch threads for easy barrel removing for loading.
- Locking follower rod, heavy duty bevelled follower and spring.
- Supplied ready to fill using various methods (cartridge, loader pump and suction).

101 200

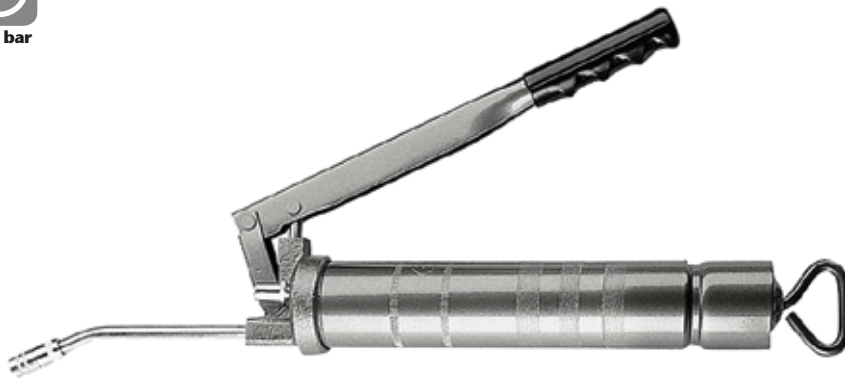

Locking with ratchet

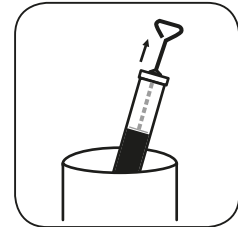

Suction filling

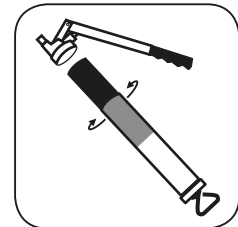

Cartridge loading

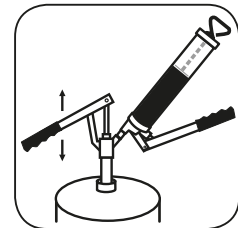

Loading with filler pump

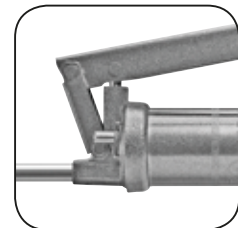

Rugged cast-iron pump head for durability

500 CC LEVER ACTION GREASE PUMPS

Universal grease pumps to be used with 400 g (14 oz) grease cartridges or with bulk grease. Bulk grease loading by suction or using a filler pump. Maximum working pressure: 500 bar (7,250 psi).

101 202, 500 cc lever action grease pump

Individually boxed, grease pump includes filler valve 128 003.

101 200, 500 cc lever action grease pump

Individually boxed, grease pump includes filler valve 128 003 and rigid stem with a four jaw hydraulic connector (PN 710 214).

101 240, 500 cc lever action grease pump

Individually boxed, grease pump includes filler valve 128 003 and 300 mm single braided rubber hose with a four-jaw hydraulic connector (PN 137 031).

101 211, 500 cc lever action grease pump

Packed in Individual plastic bag, grease pump includes rigid stem with a four jaw hydraulic connector (PN 710 214).

101 300, 600 cc lever action grease pump

101 800, 1.000 cc lever action grease pump

MANUAL HAND HELD GREASE PUMPS

106 200

500 CC PISTOL GRIP GREASE PUMPS



250 bar



Pistol grip grease pump for hard to reach lubrication points. Three way loading: 400 g (14 oz) cartridges, bulk grease suction or filler pump. Heavy duty cast iron head with precision fit piston. Maximum working pressure: above 250 bar (3,650 psi).

106 200 - 500 cc pistol grip grease pump

Individually boxed, grease pump includes filler valve 128 003 and straight rigid stem with a four jaw hydraulic type connector (PN 710 710).

106 240 - 500 cc pistol grip grease pump

Individually boxed, grease pump includes filler valve 128 003 and with 300 mm single braid reinforced outlet hose with a four-jaw hydraulic type connector (PN 137 031).

102 102 - 102 103

PUSH ACTION GREASE PUMPS



150 bar



Push action grease pumps. They deliver grease or oil at 150 bar maximum pressure when pushed on a grease nipple. Full metal construction for bulk grease.

102 100, 60 cc metal barrel, zerk nozzle (grease/oil).

102 101, 60 cc metal barrel, concave nozzle (grease/oil).

102 102, 150 cc metal barrel, zerk nozzle (grease/oil).

102 103, 150 cc metal barrel, concave nozzle (grease/oil).

109 900

LEVER ACTION GREASE PUMPS FOR BULK GREASE



500 bar



All grease pumps are individually boxed and include filler nipple for loading with a filler pump and a rigid stem with a four jaw hydraulic connector.

109 900, 300 cc lever action grease pump

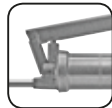

Rugged cast-iron pump head for durability



Locking with pin



Suction filling



Loading with filler pump

100 900

500 CC LEVER ACTION GREASE PUMP WITH VARIABLE STROKE



700 bar



100 900, 500 cc lever action grease pump with variable stroke

Heavy duty lever grease pump for use with bulk grease or 400 g (14 oz) grease cartridges. Grease pump features variable stroke, which delivers high pressure on the short stroke and high volume on a full stroke. Includes heavy duty cast iron head with hardened and ground piston, bleeder valve, filler nipple, removable check valve and barrel cap for cleaning, and 360° positionable outlet stem with four jaw hydraulic connector.

100 940, 500 cc lever action grease pump with variable stroke

Similar to PN 100 900 but includes a 300 mm single braided rubber hose with a four-jaw hydraulic connector (PN 137 031).

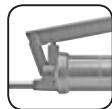

Rugged cast-iron pump head for durability



Variable stroke action



Suction filling



Cartridge loading



Loading with filler pump

167 500 - 168 600



HAND HELD AIR OPERATED GREASE PUMPS

High pressure, 60:1 pressure ratio, air operated grease pumps. They can be connected to a compressed air line or to the air brake circuit of a commercial vehicle. Delivery: 1 cc each time the trigger is pressed. Maximum air pressure: 10 bar, Air connection thread 1/4" BSP (F).

167 500, 1.000 cc air operated grease pump

Includes a 1.000 cc barrel with an air driven grease follower. Recommended for high viscosity grease and low temperatures. Supplied with 400 mm double steel braid reinforced outlet hose with 4 jaw connector (PN 140 040) and filler nipple. Bulk grease loading using a grease filler pump.

168 600, 500 cc air operated grease pump

Includes a 500 cc barrel with a spring driven grease follower. Three way loading: 400 g (14 oz) grease cartridges, bulk grease suction or with a grease filler pump. Supplied with filler nipple and 400 mm double steel braid reinforced outlet hose with four jaw connector (PN 140 040) and filler nipple.

168 601, 500 cc air operated grease pump

Similar to model 168 600, includes rigid outlet stem with four jaw connector (PN 710 214).

160 100



450 bar

Ni-MH

18V



Cartridge loading



Loading with filler pump (using filler valve: 128 003)

BATTERY GREASE PUMPS

160 100, 18 V NiMH battery grease pump

For use with standard grease cartridges or bulk grease. High pressure delivery, up to 500 bar (7,200 psi) and 80 g/min. Supplied with two high capacity 18 V rechargeable NiMH batteries, 230 V quick battery charger, 1 m outlet hose with hydraulic coupler, bleeder valve and carrying strap. Pump is delivered in a heavy duty carrying case.

160 101, 18 V Li-ION battery grease pump

Same as model 160 100 but with Li-ION batteries.

128 003 - 128 005

FILLER VALVES AND LOADER FITTINGS



128 003 Grease gun filler valve, Ø 9 mm.

128 033 Grease gun filler valve, Ø 12,5 mm.

128 005 Grease loader fitting

For Ø 9 mm valve. 1/4" BSP (M).

128 004 Grease loader fitting.

For Ø 12,5 mm valve. 1/4" BSP (M).

108 050

GREASE GUN FILLER PUMPS

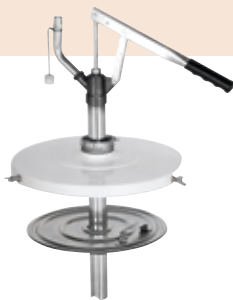

For quick, clean and easy loading of hand, air or battery operated grease guns fitted with a filler valve. Each unit includes a medium pressure lever action pump with two loader fittings that fit the more popular filling valves (Ø 9 mm and Ø 12,5 mm), drum cover and follower disc.

108 000 Grease gun filler pump for 12, 18 kg kegs

Includes a 310 mm drum cover.

108 050 Grease gun filler pump for 20 kg kegs

Includes a 330 mm drum cover.

108 100 Grease gun filler pump for 50 kg drums

Includes a 405 mm drum cover.

108 502

FILLER PUMPS FOR CENTRALIZED GREASING UNITS



Medium pressure lever action pump with 1,5 m hose and a 2-HK (1/4") hydraulic connector for filling the reservoir of centralized greasing systems. Includes pump, cover, hose, and hydraulic connector.

108 501 Filler pump for centralized greasing systems, 12 - 18 kg kegs

Includes a 310 mm drum cover.

108 502 Filler pump for centralized greasing systems, 20 kg kegs

Includes a 330 mm drum cover.

108 503 Filler pump for centralized greasing systems, 50 kg drums

Includes a 405 mm drum cover.

GREASE COMPRESSORS AND BUCKET PUMPS

151 102



HIGH PRESSURE GREASE PUMPS

High pressure steel pumps to be mounted directly onto original grease kegs. Maximum pressure: 350 bar (5,000 psi). Delivery per stroke 2 cc.

Pump equipped with carrying handle, cover with pump adaptor, follower disc and 1,5 m high pressure hose with rigid stem and four-jaw hydraulic connector.

151 100 High pressure grease pump for 12.5 to 18 kg kegs

Includes a 310 mm drum cover.

151 102 High pressure grease pump for 20 kg kegs

Includes a 330 mm drum cover.

150 000



BUCKET PUMPS

Bucket pumps include a 16 litre leak proof, all steel oval shaped bucket with carrying handle and foot rest for easy handling and stability.

150 000 Multipressure grease bucket pump 16 kg

Heavy duty high capacity grease pump with three alternative lever positions, which can be used under any operating conditions and with all type of lubricants (winter / summer, high or low viscosity grease, oil). Maximum pressure range between 175 to 350 bar (2,500 to 5,000 psi) with a delivery of 20 gr, 15 g or 10 g per stroke depending on the position of the lever chosen. Pump includes 1,5 m high pressure hose with a three-jaw hydraulic connector (PN 715 429).

320 400 Oil bucket pump 16 litres

For dispensing high viscosity lubricants. Includes a medium pressure lever action pump (100 cc delivery per stroke) with a 1,5 m rubber hose with shut off valve and 135° angled nozzle.

320 400



157 000

PEDAL ACTION GREASE PUMP 5 kg



157 000 Pedal action grease pump

Pedal action heavy-duty grease pump. Spring primed follower plate and cast iron pump mechanism ensures that the pump can be used even with extremely viscous grease. Maximum pressure: 500 bar (7,150 psi). Delivery per pedal stroke: 2 g.

Steel leak proof reservoir, can hold up to 5 kg of grease. Includes air bleeder valve and 2 m high pressure grease hose with a four jaw hydraulic connector with check valve.

DRUM PUMPS FOR OIL

306 100 - 314 540



MEDIUM PRESSURE PUMPS

Lever action transfer pumps for high viscosity lubricants. Pump includes 2" height adjustable bung adaptor to fit directly onto drums, covers or containers. Pump with steel suction tube, foot valve and piston and NBR seals. Delivery: 100 cc per stroke. Outlet thread: 3/4" BSP (M).

Medium pressure transfer pump

306 300 for 20 litre pails.
450 mm long suction tube.
306 200 for 20 and 60 litre drums. 620 mm long suction tube.
306 100 for 60 litre drums. 760 mm long suction tube.
306 400 for 205 litre drums. 1.100 mm long suction tube.

Accessories:

730 603 Angled steel delivery spout
Fits directly to the pump outlet.

314 530 Delivery hose
Transparent 1,5 m hose with 135° nozzle.

314 540 Delivery hose. 1,5 m rubber hose, with shut off valve and 135° nozzle.

308 010



ROTARY PUMPS

308 010 Aluminium rotary action drum pump

For transfer of light to medium viscosity petroleum based fluids. Aluminium pump body with zamak rotor and shaft. Delivery 0,3 litre per revolution. Pump includes height adjustable bung adaptor, three pieces suction tube and 1 m delivery hose.

308 300 Cast-iron rotary action drum pump

For transfer of light to medium viscosity petroleum based fluids. Cast-iron pump body with steel shaft. Delivery 0,3 litre per revolution. Pump includes height adjustable bung adaptor, three pieces suction tube with foot valve and 1 m delivery hose.

605 000



HIGH PERFORMANCE DRUM PUMP

605 000 High performance drum pump

Lever action transfer pump for use with all types of lubricants, even those with higher viscosity, like gear oil. Lever can be mounted in four different positions that changes the delivery volume per stroke: 0,10 litre, 0,15 litre, 0,20 litre or 0,25 litre per stroke. Pump includes telescopic suction tube that can be used with 60 and 205 litre drums and 2" bung adaptor.

Not included option:

314 540 Rubber delivery hose, 1,5 m, with shut off valve and nozzle.

304 500



LEVER ACTION DRUM PUMP

304 500 Lever action drum pump

Lever action drum pump for the transfer of light lubricants from 60 to 205 litre drums. Steel pump body, delivery spout and telescopic suction tube. Steel piston with brass rings and NBR seals. With 2" and M64 x 4 bung adaptors. Delivery 0,45 litre per stroke.

304 509 Lever action drum pump with Viton® seals

Can be used with fluids like antifreeze and other non corrosive fluids. To avoid pump corrosion, it is recommended to flush the pump with diesel after its use with other fluids than lubricants.

320 300



GEAR OIL DISPENSERS

320 300 Gear oil dispenser

With 330 mm cover for 20 litre pails and 1,5 m transparent hose with nozzle.

320 310 Gear oil dispenser

With 310 mm cover for 12 to 18 litre pails and 1,5 m transparent hose with nozzle.

741 602 Carrying handle

Fits on 310 and 330 mm drum covers.

DRUM PUMPS FOR VARIOUS FLUIDS

300 401 - 300 500



LIFT ACTION PUMPS FOR CHEMICAL FLUIDS

300 401 Lift action pump for chemical products, 205 litre drums

Lift action pump with polypropylene covered piston and PTFE seals. 1.000 mm suction tube, 2" bung adaptor and outlet spout. Black pump with red bung adaptor and spout nut. Recommended for use with acid based fluids, detergents and kerosene based solvents.

300 400 Lift action pump for chemical products, 20-25-50 litre drums

Same as model 300 401, but with 500 mm suction tube for 20, 25, 50 litre drums.

300 500 Lift action pump for chemicals, 20, 25, 50 litre drums

Lift action pump with nylon covered piston and PTFE seals. 500 mm suction tube, Ø 60 mm bung adaptor with three screws and outlet spout. Black pump with yellow bung adaptor and spout nut. Recommended for use with solvents.

300 501 Lift action pump for chemical products, 205 litre drums

Same as model 300 500, but with 1.000 mm suction tube for 205 litre drums.

NOTE: Please check fluid compatibility with the pump prior to its use.

302 001



SYPHON TRANSFER PUMP

302 001 Syphon transfer pump

Lever action syphon pump. Design allows transfer by siphoning once the pump has been primed, giving a continuous flow of 8 l/min. Bung thread fits 50 and 205 litre drums. With 1,5 m clear delivery hose, metal nozzle and PVC suction tube. For anti-freeze, light mineral oils, diesel, detergent and other automotive and light petroleum fluids.

300 006



PLASTIC LEVER PUMPS

Lever action pumps with a unique toggle mechanism that provides very a smooth operation.

Pumps are manufactured in polypropylene and include a 2" bung adaptor with a lockable nut that allows placing the pump in its optimal position for an easier lever action.

Pump delivery per stroke: 500 cc.

Includes delivery hose.

300 006 Lever action pump, polypropylene/EPDM

Blue color pump with EPDM seals. Can be used with AdBlue®/DEF.

300 007 Lever action pump, polypropylene/Viton®

Red color pump, with Viton® seals. Compatible with a wide range of chemicals.

300 009 Lever action pump, polypropylene/NBR

White color pump, with NBR seals. Compatible with lubricants.

308 200



PVC ROTARY ACTION DRUM PUMP

308 200 PVC rotary action drum pump (Polypropylene/EPDM)

For the continuous transfer of acid-based corrosive fluids and water based fluids from 20, 50 or 205 litre drums. PVC pump with stainless steel shaft.

Delivery 0,25 l per revolution. Pump includes height adjustable bung adaptor, three pieces suction tube and delivery hose.

FUNNELS, MEASURES, GRAVITY COCKS, JERRY CANS AND OIL SUCTION PUMPS

670 019 - 671 030



FUNNELS

Funnels with flexible spout

No spill, no splash, quick discharge funnels. With filter and flexible spout for hard to reach places.

670 019* Funnel with filter and flexible spout

190 mm diameter. 2 litre capacity.

670 023* Funnel with filter and flexible spout

230 mm diameter. 3,5 litre capacity.

* For orders over 1.000 units, you can customize it.

INDUSTRIAL FUNNELS

Large capacity funnels, 5 litre. 300 x 200 x 300 mm.

671 030 Industrial funnel

With filter for diesel.

671 031 Industrial funnel

With filter for lubricants.

FUNNELS ACCESSORIES

679 010 Filter for 670 019

679 011 Filter for 670 023

679 001 Small flexible extension

For 1, 2 and 3 litre measures and for Ø 190 mm diameter funnels.

679 002 Large flexible extension

For 5 litre measures and for 230 mm diameter funnels.

675 002



MEASURES

Fluid Measures

For lubricants, antifreeze, brake fluid, petroleum, diesel, etc. Moulded in high density polyethylene, with flexible spout.

675 001 Plastic measure

Graduated 0 - 1 litre.

675 002 Plastic measure

Graduated 0 - 2 litre.

675 003 Plastic measure

Graduated 0 - 3 litre.

675 005 Plastic measure

Graduated 0 - 5 litre.

MEASURES ACCESSORIES



679 009

679 007 Plastic cover for 675 001

679 008 Plastic cover for 675 002 and 675 003

679 009 Plastic cover for 675 005

622 020



STEEL JERRYCANS

Green colour with protective paint in the inside. With no outlet spout.

622 005, 5 litres Jerrycan U.N. approved

622 010, 10 litres Jerrycan U.N. approved

622 020, 20 litres Jerrycan U.N. approved

Options:

629 001 Painted outlet spout for jerry cans.

629 002 Zinc plated outlet spout for jerry cans.

318 000 - 318 001



GRAVITY COCKS

Fit 60 to 205 litre drums placed horizontally. Cocks include automatic shut off valve.

318 000 Gravity cock

3/4" BSP (M).

318 001 Gravity cock

2" BSP (M).

113 910



OIL SUCTION PUMPS

For lubricant suction and discharge for loading or refilling transmissions, gear boxes, filters, etc.

113 710 Oil suction pum

500 cc with 290 mm PVC hose.

113 700 Oil suction pum

500 cc with one angled and one straight steel outlets.

113 910 Oil suction pum

800 cc with 290 mm PVC hose.

GENERAL INFORMATION

Air line filters

To protect valves, pump motors or pneumatic tools from damage or wear caused by dirt and moisture contained in compressed air. Semiautomatic bleeding valve.

Pressure regulator

To maintain a selected air pressure constant (between 0 to 12 bar) eliminating over pressure risks and erratic operation of equipment. Also available combined with an air filter forming a compact unit.

Air line lubricators

To create an oil mist that helps increase service life of pumps and other air tools. Oil fill port on top and oil mist adjustment knob.

240 000



241 001



242 102



AIR TREATMENT COMPONENTS Ø 1/4"

Maximum working pressure 12 bar.
Connection threads: 1/4" BSP (FF).

240 000 Combined air filter, regulator and lubricator, Ø 1/4"

240 500 Combined air filter, regulator, Ø 1/4"
0 to 12 bar.

240 201 Air line regulator, Ø 1/4"
Without pressure gauge.

240 200 Air line regulator, Ø 1/4"
With pressure gauge.

240 300 Air filter, Ø 1/4"
Semiautomatic bleeding.

240 400 Air lubricator, Ø 1/4"

AIR TREATMENT COMPONENTS Ø 1/2"

Maximum working pressure 12 bar.
Connection threads: 1/2" BSP (FF) with 1/2" BSP (M) - 3/8" BSP (F) adaptors.

241 001 Combined air filter, regulator and lubricator, Ø 1/2"

241 501 Combined air filter, regulator, Ø 1/2"
0 to 12 bar.

241 201 Air line regulator, Ø 1/2"
0 to 12 bar.

241 301 Air filter, Ø 1/2"
Semiautomatic bleeding.

241 401 Air lubricator, Ø 1/2"

AIR TREATMENT COMPONENTS Ø 3/4"

Maximum working pressure 16 bar.
Connection threads: 3/4" BSP (FF).

242 102 Combined air filter - regulator and lubricator, Ø 3/4"

242 202 Air line regulator, Ø 3/4"
0 to 12 bar.

242 302 Air filter, Ø 3/4"
Semiautomatic bleeding.

242 402 Air lubricator, Ø 3/4"

246 010

AIR HOSES

Low pressure hoses for compressed air with female swaged fitting and double male adaptor.



PART No.	LENGTH	INT. Ø	CONNECTION THREADS	WORKING PRESSURE
246 006	0,6 m	1/4" - 6 mm	1/4" BSPT (MM)	15 bar
246 010	1,0 m	1/4" - 6 mm	1/4" BSPT (MM)	15 bar
246 015	1,5 m	1/4" - 6 mm	1/4" BSPT (MM)	15 bar
246 030	3,0 m	1/4" - 6 mm	1/4" BSPT (MM)	15 bar
246 060	6,0 m	1/4" - 6 mm	1/4" BSPT (MM)	15 bar
246 100	10,0 m	1/4" - 6 mm	1/4" BSPT (MM)	15 bar
246 150	15,0 m	1/4" - 6 mm	1/4" BSPT (MM)	15 bar
247 706	0,6 m	3/8" - 10 mm	3/8" BSPT (M) - 1/2" BSPT (M)	15 bar
247 710	1,0 m	3/8" - 10 mm	3/8" BSPT (M) - 1/2" BSPT (M)	15 bar
247 715	1,5 m	3/8" - 10 mm	3/8" BSPT (M) - 1/2" BSPT (M)	15 bar

AIR COUPLERS AND CONNECTION ADAPTORS FOR COMPRESSED AIR

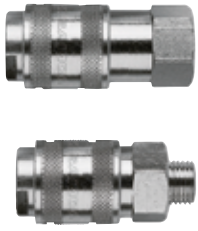

Manufactured in brass, with nickel plated body and stainless steel wear parts for a longer life. Compatible with US MIL C4109 - ISO 6150 B12. Flow capacity: 1.000 l/min.



Safety quick couplers for compressed air. One-step release and exhaust operation quickly vents system pressure allowing for a safe disconnect. Manufactured in Stainless steel, nickel plated brass, NBR and technopolymer. Couplers conform with ISO 6150 B12. Flow capacity: 1.200 l/min. Pressure range: 1 to 15 bar.

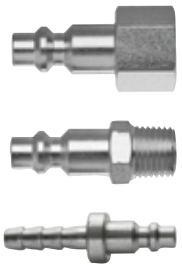

For use with standard and industrial series Ø 1/4" quick couplings. Compatible with US MIL C4109 - ISO 6150 B12.

STANDARD SERIES QUICK COUPLING Ø 1/4"	
FEMALE AUTOMATIC QUICK COUPLING Ø 1/4"	
PART No.	CONNECTION THREAD
253 114	1/4" BSP (F)
253 138	3/8" BSP (F)
253 112	1/2" BSP (F)
MALE AUTOMATIC QUICK COUPLING Ø 1/4"	
PART No.	CONNECTION THREAD
253 014	1/4" BSP (M)
253 038	3/8" BSP (M)
253 012	1/2" BSP (M)
AUTOMATIC QUICK COUPLING WITH HOSE CONNECTOR	
PART No.	HOSE
253 206	6 mm (1/4")
253 208	8 mm (5/16")
253 210	10 mm (3/8")
253 213	13 mm (1/2")

SAFETY COUPLERS	
SAFETY COUPLERS WITH FEMALE BSP THREAD	
PART No.	CONNECTION THREAD
250 614	1/4" BSP (F)
250 638	3/8" BSP (F)
250 612	1/2" BSP (F)
SAFETY COUPLERS WITH MALE BSP THREAD	
PART No.	CONNECTION THREAD
250 514	1/4" BSP (M)
250 538	3/8" BSP (M)
250 512	1/2" BSP (M)
SAFETY COUPLERS WITH HOSE BARB	
PART No.	CONNECTION
250 708	8 mm (5/16")
250 710	10 mm (3/8")

AIR NIPPLES Ø 1/4"	
FEMALE AIR NIPPLES Ø 1/4"	
PART No.	CONNECTION THREAD
259 114	1/4" BSP (F)
259 138	3/8" BSP (F)
259 112	1/2" BSP (F)
MALE AIR NIPPLES Ø 1/4"	
PART No.	CONNECTION THREAD
259 014	1/4" BSP (M)
259 038	3/8" BSP (M)
259 012	1/2" BSP (M)
AIR NIPPLES WITH HOSE CONNECTOR	
PART No.	HOSE
259 206	6 mm (1/4")
259 208	8 mm (5/16")
259 210	10 mm (3/8")
259 213	13 mm (1/2")

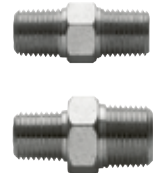
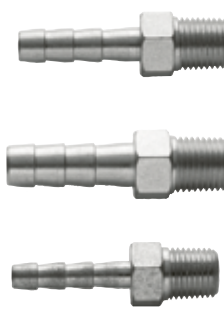

MALE HOSE ADAPTORS	
1/4" BSPT (M) HOSE ADAPTORS	
PART No.	HOSE ADAPTORS
238 102	1/4" BSPT (M) - Ø 6 mm
238 100	1/4" BSPT (M) - Ø 8 mm
238 101	1/4" BSPT (M) - Ø 10 mm
3/8" BSPT (M) HOSE ADAPTORS	
PART No.	HOSE ADAPTORS
238 301	3/8" BSPT (M) - Ø 8 mm
238 300	3/8" BSPT (M) - Ø 10 mm
238 302	3/8" BSPT (M) - Ø 13 mm
1/2" BSPT (M) HOSE ADAPTORS	
PART No.	HOSE ADAPTORS
238 500	1/2" BSPT (M) - Ø 13 mm

FEMALE HOSE ADAPTORS	
1/4" BSP (F) HOSE ADAPTORS	
PART No.	HOSE ADAPTORS
238 001	1/4" BSP (F) - Ø 6 mm
238 000	1/4" BSP (F) - Ø 8 mm
3/8" BSP (F) HOSE ADAPTORS	
PART No.	HOSE ADAPTORS
238 201	3/8" BSP (F) - Ø 8 mm
238 200	3/8" BSP (F) - Ø 10 mm
1/2" BSP (F) HOSE ADAPTORS	
PART No.	HOSE ADAPTORS
238 400	1/2" BSP (F) - Ø 13 mm

DOUBLE MALE THREAD CONNECTION ADAPTORS	
PART No.	CONNECTION ADAPTOR
239 000	1/4" BSPT (MM)
239 002	3/8" BSPT (MM)
239 004	1/2" BSPT (MM)
239 001	3/8" - 1/4" BSPT (MM)
239 005	1/2" - 1/4" BSPT (MM)
239 003	1/2" - 3/8" BSPT (MM)

MALE - FEMALE CONNECTION ADAPTORS	
PART No.	CONNECTION ADAPTOR
239 101	3/8" BSPT (M) - 1/4" BSP (F)
239 103	1/2" BSPT (M) - 3/8" BSP (F)
239 102	1/4" BSPT (M) - 3/8" BSP (F)
239 104	3/8" BSPT (M) - 1/2" BSP (F)

90° ELBOW ADAPTORS	
PART No.	CONNECTION ADAPTOR
239 300	1/4" BSP (FF)
239 302	3/8" BSP (FF)
239 303	1/2" BSP (FF)
239 350	3/8" BSP (MF)

TWO WAY AIR FLOW DIVIDERS	
PART No.	CONNECTION ADAPTOR
239 200	1/4" BSP (MF)
239 201	3/8" (MF)

10**PART NUMBER INDEX**

PART No.	PAGE	PART No.	PAGE	PART No.	PAGE	PART No.	PAGE
011 060 108	015 220 108	032 060 109	122 011 110
011 100 108	015 240 108	032 160 109	123 001 110
011 140 108	015 260 108	032 220 109	123 011 110
011 160 108	015 280 108	032 260 109	124 011 110
011 180 108	015 300 108	032 600 109	126 000 110
011 220 108	015 320 108	032 620 109	126 200 110
011 240 108	015 340 108	032 740 109	126 400 110
011 260 108	015 500 108	032 939 109	126 500 110
011 280 108	015 520 108	032 949 109	128 003 113
011 300 108	015 540 108	032 959 109	128 004 113
011 320 108	015 600 108	050 001 108	128 005 113
011 340 108	015 620 108	051 060 108	128 033 113
011 500 108	015 700 108	051 160 108	128 501 110
011 520 108	015 720 108	051 220 108	136 021 110
011 540 108	015 740 108	051 260 108	136 041 110
011 600 108	015 900 108	051 600 108	136 051 110
011 620 108	015 910 108	052 060 108	136 201 110
011 700 108	021 060 109	052 160 108	137 021 110
011 720 108	021 140 109	052 220 108	137 041 110
011 740 108	021 160 109	052 260 108	137 051 110
011 900 108	021 220 109	052 600 108	137 201 110
011 910 108	021 240 109	070 000 109	140 020 110
011 930 108	021 260 109	070 001 109	140 040 110
011 940 108	021 280 109	070 002 109	140 050 79, 110
011 950 108	021 300 109			140 100 110
012 020 108	021 320 109	100 900 112	140 200 110
012 220 108	021 340 109	100 940 112	140 400 110
013 060 108	021 380 109	101 200 111	141 020 110
013 100 108	021 500 109	101 202 111	141 040 110
013 140 108	021 520 109	101 211 111	141 050 110
013 160 108	021 540 109	101 240 111	141 200 110
013 180 108	021 600 109	101 300 111	141 400 110
013 220 108	021 620 109	101 800 111	150 000 114
013 240 108	021 640 109	102 100 112	151 100 114
013 260 108	021 700 109	102 101 112	151 102 114
013 280 108	021 720 109	102 102 112	157 000 114
013 300 108	021 740 109	102 103 112	160 100 113
013 320 108	022 160 109	106 200 112	160 101 113
013 340 108	022 220 109	106 240 112	167 500 113
013 500 108	022 260 109	108 000 113	168 600 113
013 520 108	022 600 109	108 050 113	168 601 113
013 540 108	022 620 109	108 100 113	180 800 80
013 600 108	023 220 109	108 501 113	180 801 80
013 620 108	023 600 109	108 502 113	180 802 80
013 700 108	023 620 109	108 503 113	180 803 80
013 720 108	023 640 109	109 900 112	184 000 80
013 740 108	024 620 109	113 700 117	184 050 80
013 900 108	024 640 109	113 710 117	184 200 80
013 910 108	025 620 109	113 910 117	184 201 80
015 060 108	025 640 109	121 000 110	185 001 80
015 100 108	031 939 109	121 011 110	186 000 80
015 140 108	031 949 109	121 020 110	186 010 80
015 160 108	031 950 109	121 050 110	186 300 78
015 180 108	031 960 109	122 001 110	187 000 80

PART No.	PAGE	PART No.	PAGE	PART No.	PAGE	PART No.	PAGE
187 001	80	246 100	118	318 000	117	360 160	68
188 000	80	246 150	118	318 001	117	360 161	67
188 100	80	247 706	118	320 300	115	360 162	67
195 100	80	247 710	118	320 310	115	360 163	68
199 800	80	247 715	118	320 400	114	360 164	68
		250 512	119	324 000	13	360 165	68
238 000	119	250 514	119	324 010	13	360 166	68
238 001	119	250 538	119	325 000	13	360 168	68
238 100	119	250 612	119	325 010	13	361 000	101
238 101	119	250 614	119	326 000	13	361 001.370	103
238 102	119	250 638	119	326 010	13	361 002.370	103
238 200	119	250 708	119	327 020	13	361 003.370	103
238 201	119	250 710	119	328 010	12	361 100	25, 80
238 300	119	251 412	53	331 120	54	361 110	80
238 301	119	253 012	119	333 120	54	361 200	80
238 302	119	253 014	119	340 120	14	362 101	25
238 400	119	253 038	119	341 120	14	362 102	25
238 500	119	253 112	119	347 120	15	362 103	25
239 000	119	253 114	119	348 120	15	362 104	25
239 001	95, 119	253 138	53, 119	349 120	16	362 300	25
239 002	119	253 206	119	349 121	16	362 301	25
239 003	119	253 208	119	351 120	8	362 302	25
239 004	119	253 210	119	351 121	54	362 303	25
239 005	119	253 213	119	352 120	8	362 400	17
239 101	119	259 012	119	352 220	11	362 402	24
239 102	119	259 014	119	353 120	10	362 910	13
239 103	119	259 038	119	354 120	10	362 911	17
239 104	119	259 112	119	356 120	8	363 053	71
239 200	119	259 114	119	358 120	10	363 054	71
239 201	119	259 138	119	360 000	13	363 055	71
239 300	119	259 206	119	360 001	13, 17	363 056	71
239 302	119	259 208	119	360 002	17	363 100	70
239 303	119	259 210	119	360 006	24	363 112	70
239 350	119	259 213	119	360 100	53	363 114	70
240 000	118			360 101	53	363 115	70
240 200	25, 45, 118	300 006	116	360 102	13, 17, 25	363 116	70
240 201	118	300 007	116	360 106	25	363 117	70
240 300	53, 118	300 009	116	360 107	25	363 118	70
240 400	25, 45, 118	300 400	116	360 108	25	364 030	101
240 500	25, 45, 53, 95, 118	300 401	116	360 111	67	365 300	78
241 001	118	300 500	116	360 113	35, 67	365 521	72
241 201	25, 45, 53, 118	300 501	116	360 114	67	365 532	72
241 301	118	302 001	116	360 115	67	365 534	72
241 401	25, 45, 118	304 500	115	360 117	67	365 535	72
241 501	25, 45, 53, 118	304 509	115	360 118	67	365 536	72
242 102	118	306 100	115	360 119	67	365 537	72
242 202	25, 45, 118	306 200	115	360 120	13, 17, 25	365 538	72
242 302	25, 45, 118	306 300	115	360 121	24, 25	365 575	78
242 402	25, 45, 118	306 400	115	360 122	67	365 654	73
246 006	118	308 010	115	360 127	67	365 655	73
246 010	118	308 200	116	360 132	24, 25	365 656	73
246 015	118	308 300	115	360 134	35	365 657	73
246 030	118	314 530	115	360 135	35, 67	365 801	74
246 060	118	314 540	115	360 137	53, 101, 103	365 802	74

PART No.	PAGE	PART No.	PAGE	PART No.	PAGE	PART No.	PAGE
365 803	74	373 300	94	402 000	32	425 150.002	31
365 804	74	373 400	94	402 025	32	425 290	31
365 805	74	373 500	93	402 050	32	426 243	33
365 806	74	373 600	93	404 100	30	428 243	31
365 811	75	376 300	12	405 100	30	428 262	31
365 812	75	376 610	12	407 200	30	429 800	33
365 813	75	378 120	12	409 200	30	429 810	33
365 824	74	379 000	11	411 100	79	430 000	35
365 826	74	379 003	11	412 101	46	431 000	35, 96
366 000	76	379 300	11	412 102	46	431 001	35
366 010	76, 103	379 400	17	412 103	46	432 000	35, 67, 96
366 020	76	379 403	17	412 104	46	432 814	35, 67
366 050	77, 88	379 404	17	412 190	46	435 000	94
366 053	77	379 500	17	412 202	46	436 000	94
366 055	77, 88	379 503	17	412 203	46	436 100	94
366 057	77	379 504	17	412 391	46	439 100	94
366 060	76	379 710	95	412 392	46	453 602	33
366 550	80	379 711	95	412 920	46	454 002	9
366 760	103	381 000	84	413 077	79	454 003	9
366 761	103	381 002	88	413 080	79	454 009	9
366 976	103	381 003	88	413 081	79	454 010	9
367 000	13, 17	381 004	88	413 082	79	454 100	11
367 003	13, 17	381 005	88	414 100	79	454 110	11
367 011	13	381 013	89	414 200	79	454 111	11
367 012	13	381 030	90	414 300	79	454 150	11
367 016	24	381 102	85	415 000	79	454 600	12
367 102	13	381 200	85	415 002	79	454 605	12
369 224	78	381 351	84	417 001	35	454 651	12
369 228	78	381 352	84, 86	417 002	35	454 653	12
369 230	78	381 353	84	417 003	35	454 659	12
369 232	78	381 500	84	417 004	35	454 694	12
369 234	78	381 550	85	417 005	35	454 695	12
369 236	78	381 600	84	417 006	35	454 697	12
369 237	78	381 700	85	417 009	45	454 699	12
369 241	78	381 901	85	417 010	45	480 021	35
369 244	78	381 905	85	417 011	45	480 050	35
369 601	25	381 910	85	418 002	35	482 200	31
369 606	78	381 911	85	418 004	35	482 500	31
369 900	25, 53	381 912	85	418 006	35	486 200	34
370 400	12	381 950	84, 85	418 013	35	486 500	33
371 600	93	382 001	87	418 016	35		
372 000	93	382 005	87	418 017	45	500 115	66
372 002	96	382 050	87	418 026	45	500 116	66
372 003	96	382 100	86	423 020	34	501 100	58
372 100	93	382 101	86	423 150	33	501 198	58
372 200	94	382 110	86	424 060	34	501 200	58
372 300	94	382 113	89	424 061	34	501 298	58
372 400	94	382 120	86	424 150	31	501 300	58
372 500	93	382 201	87	424 152	31	501 398	58
372 600	93	389 001	88	424 170	31	502 700.400	59
373 000	93	389 012	86	424 170.800	31	502 701.400	59
373 002	96	389 013	86, 87, 88	424 172	31	502 702.400	59
373 100	93	389 020	87	424 172.710	31	502 710.400	59
373 200	94	391 022	42	425 150	31	502 711.400	59

PART No.	PAGE	PART No.	PAGE	PART No.	PAGE	PART No.	PAGE
502 720.400	59	507 202	61	534 420	42	561 013	105
502 790.400	59	507 212	61	534 421	43	561 014	105
502 791.400	59	507 222	61	534 440	42	561 024	104
502 792.400	59	507 300	61	534 441	42	561 025	105
502 793.400	59	507 301	61	534 710	42	561 026	105
504 150	62	507 311	61	534 711	44	561 100	104
504 159	62	507 321	61	534 720	42	561 101	104
504 250	62	507 421	61	534 721	43	561 110	104
504 259	62	507 503	61, 96	534 740	42	561 200	104
504 350	62	507 762	61	534 741	42	561 201	104
504 351	62	507 782	61	534 810	42	561 210	104
504 359	62	507 920	61	534 811	44	561 300	104
504 359.001	62	507 920.001	61	534 820	42	561 301	104
504 450	62	507 921	61	534 821	43	561 310	104
504 459	62	507 921.001	61	534 840	42	561 610	104
505 224	63	507 922	61	536 010	21	561 611	104
505 232	63	507 922.001	61	536 030	21	561 613	104
505 332	63	507 930	61	536 330	19	561 614	104
505 339	63	507 934	61	536 630	20	561 615	104
505 524	63	507 935	61	537 130	23	562 000	105
505 529	63	507 936	61	537 630	22	562 010	105
505 924	63	507 942	61	539 009	24	562 100	105
505 932	63	507 950	61	551 010	51	569 000	103
506 101	60	507 976	61	551 020	51	569 001	103
506 121	60	507 978	61	551 162	50		
506 122	60	508 125	64	551 164	50	601 202	54
506 202	60	508 225	64	552 010	51	605 000	115
506 212	60	508 234	64	552 124	52	609 007	13, 17, 24
506 222	60	508 244	64	552 162	50	609 008	24
506 300	60	508 252	64	552 164	50	609 104	24
506 301	60	508 810	65	553 124	52	612 100	66
506 311	60	508 890	65	553 162	50	612 200	66
506 321	60	508 924	64	553 164	50	612 400	66
506 421	60	508 925	64	554 010	51	622 005	117
506 503	60, 96	508 942	64	554 020	51	622 010	117
506 762	60	508 944	64	558 338	53	622 020	117
506 782	60	531 210	37	559 100	95	629 001	117
506 920	60	531 410	38	559 110	95	629 002	117
506 920.001	60	531 420	38	560 212	102	670 019	117
506 921	60	531 430	38	560 224	102	670 023	117
506 921.001	60	531 710	39	560 230	102	671 030	117
506 922	60	531 720	39	560 300	102	671 031	117
506 922.001	60	531 730	39	560 301	102	675 001	117
506 930	60	532 130	40	560 302	102	675 002	117
506 934	60	532 810	41	560 303	102	675 003	117
506 935	60	532 820	41	560 304	102	675 005	117
506 936	60	534 103	46	560 310	102	679 001	117
506 942	60	534 121	43	560 320	102	679 002	117
506 950	60	534 141	42	560 901	53, 103	679 007	117
506 976	60	534 210	42	560 902	103	679 008	117
506 978	60	534 240	42	560 903	103	679 009	117
507 101	61	534 410	42	560 904	103	679 010	117
507 121	61	534 411	44	560 906	103	679 011	117
507 122	61	534 414	42	561 012	104	680 300	101

PART No.	PAGE	PART No.	PAGE	PART No.	PAGE	PART No.	PAGE
680 301	101	689 031	101, 103	737 959	96	950 353	95, 96
684 450	98	689 035	101	737 967	96	950 358	45
684 451	98	689 036	101	737 972	96		
684 460	98	689 037	101	741 300	79		
684 461	98	689 040	101	741 304	79		
684 464	98	689 041	101, 103	741 306	79		
684 465	98	689 042	101, 103	741 602	115		
684 512	98	689 044	101	741 604	45		
684 514	98	689 045	53	741 605	45		
684 524	98	689 046	53	743 305	96		
684 526	98	689 047	101, 103	753 110	45		
684 527	98	689 048	101, 103	756 200	101		
684 530	98	689 052	101				
684 531	98	689 053	101	930 505	103		
684 951	98	689 054	53	930 507	103		
685 708	100	689 055	53, 103	932 025	103		
685 709	100	689 056	53	945 513	25, 96		
685 710	100	689 058	53	945 548	25		
685 712	100	689 059	53	945 551	25, 53, 95, 96		
685 713	100	689 060	53	945 552	25, 53		
685 715	100	689 061	53	945 554	25, 53		
685 716	100	689 062	53	945 555	25, 53		
685 717	100	689 072	53	945 556	25		
685 718	100	689 073	53	945 557	25		
685 719	100	689 079	53	945 558	25		
685 720	99	689 090	101	945 565	25, 53		
685 721	99	689 091	101	945 567	25, 53		
685 722	99	689 098	101	945 572	25		
685 741	99	689 099	101	945 580	53		
685 742	99	689 910	101	945 590	25		
685 743	99			945 592	25		
685 750	99	710 214	110	945 593	53		
685 751	99	710 297	110	945 670	17, 25, 53		
685 752	99	710 298	110	945 681	25, 53		
685 753	99	710 659	110	945 708	103		
685 754	99	710 710	110	945 724	24, 25		
685 755	99	730 603	115	945 737	24		
685 771	99	736 229	68	945 738	25		
685 772	99	736 349	85	950 230	53		
685 777	100	736 353	85	950 300	25, 45, 53		
685 778	100	736 377	85	950 302	25		
685 974	99	736 771	24	950 303	25, 53, 95		
688 001	101	736 772	24	950 304	25, 45		
688 100	101	737 435	53	950 305	25, 45		
688 300	101	737 946	96	950 306	25, 53		
689 015	101	737 947	96	950 308	25,		
689 016	101	737 948	96	950 312	25, 53		
689 017	101	737 949	96	950 318	25, 45		
689 018	101	737 950	96	950 319	25, 45		
689 019	101	737 952	96	950 320	25, 45, 53		
689 021	101	737 953	96	950 321	25		
689 022	101	737 954	96	950 328	25, 45		
689 023	101	737 955	96	950 329	25, 45		
689 030	101, 103	737 958	96	950 352	96		

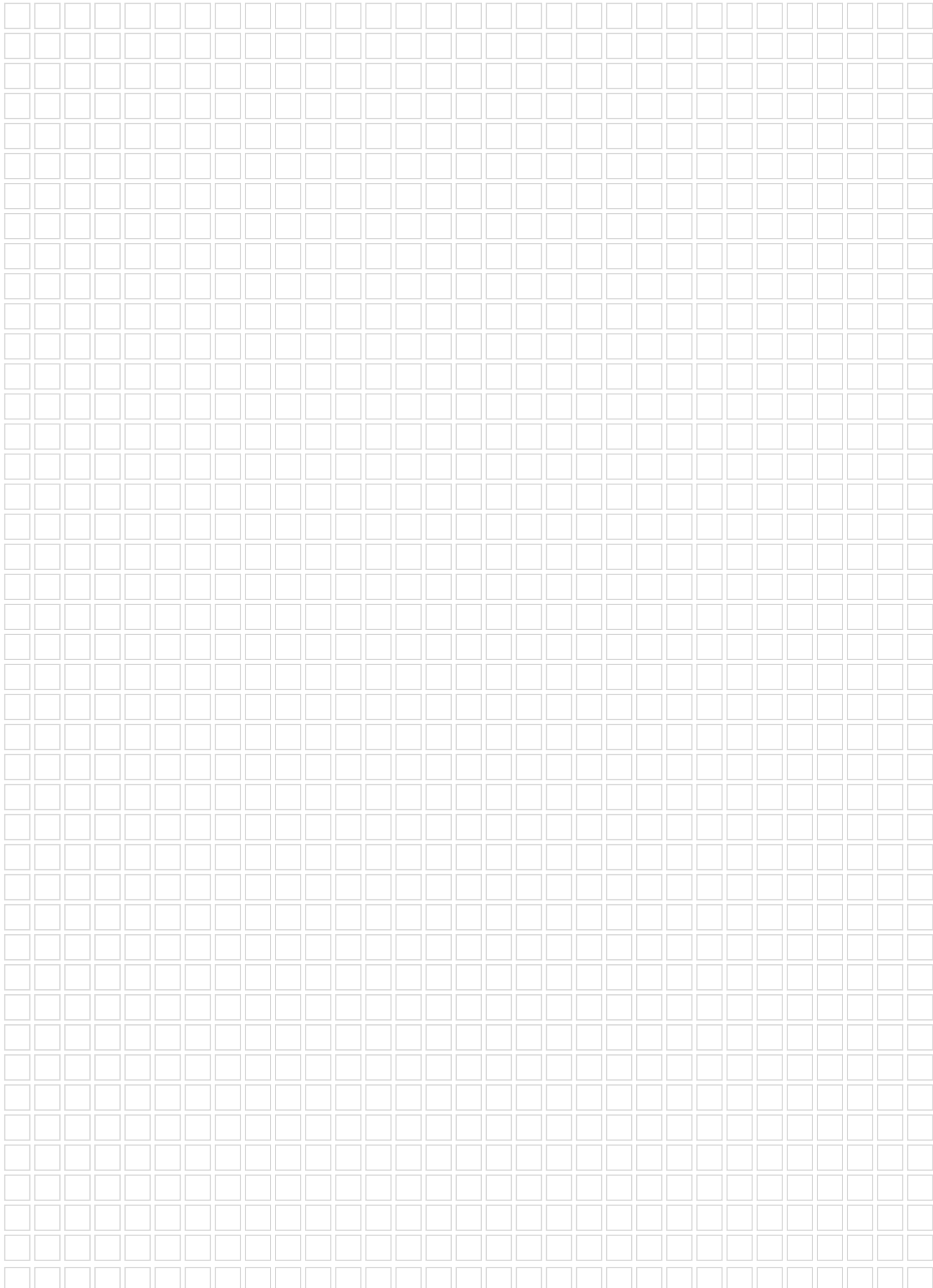

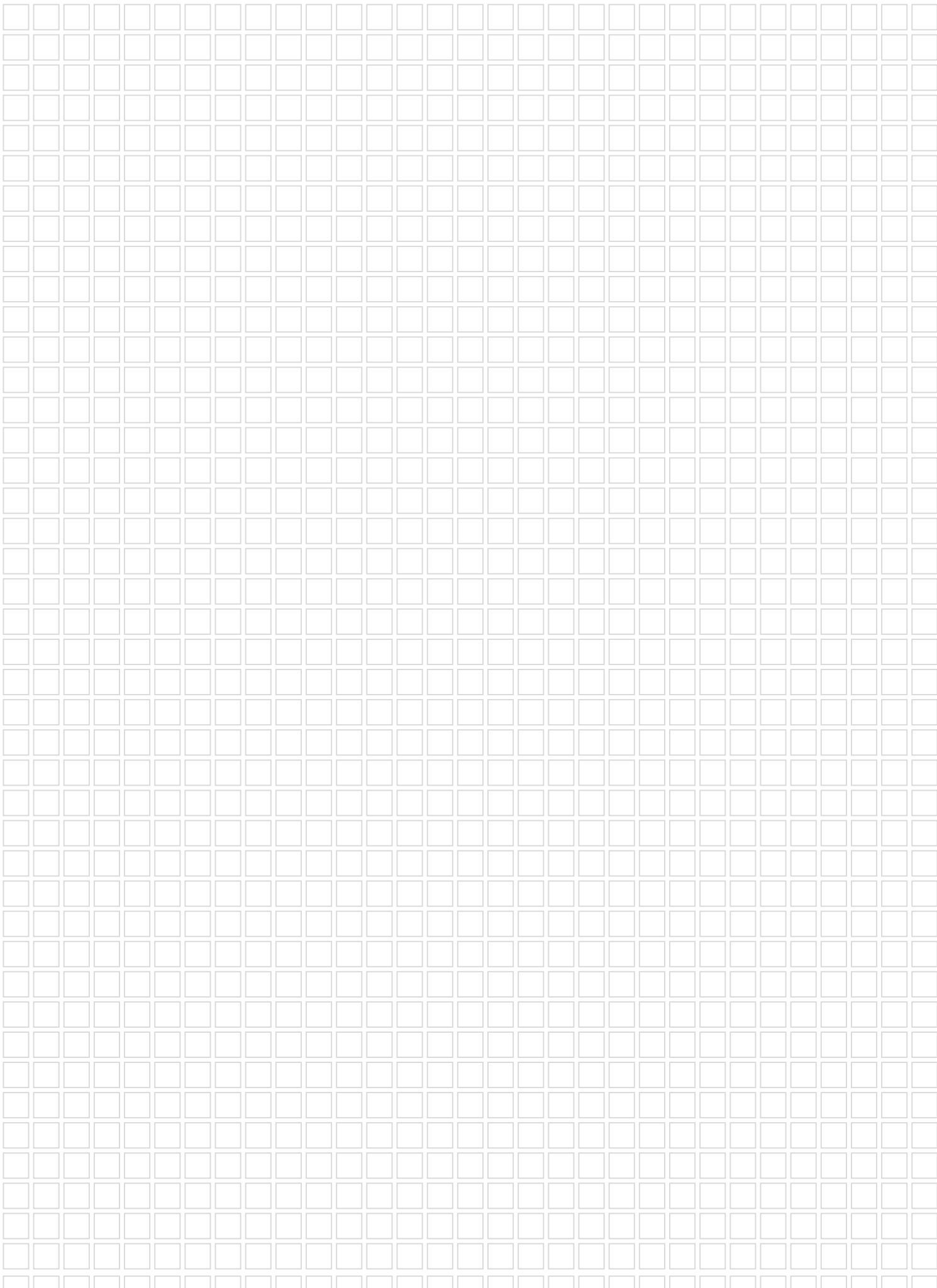



SAMOA INDUSTRIAL, S.A. - HEADQUARTERS

SPAIN AND EXPORT MARKETS

POL. IND. PORCEYO, I-14 - CAMINO DEL FONTÁN, 831

E-33392 GIJÓN (ASTURIAS), SPAIN

TEL.: +34 985 381 488 - FAX: + 34 985 147 213

export@samoaindustrial.com - www.samoaindustrial.com

SAMOA LTD.

UNITED KINGDOM AND REP. OF IRELAND

ASTURIAS HOUSE - BARRS FOLD ROAD

WINGATES INDUSTRIAL PARK

WESTHOUGHTON, BL5 3XP, UK

TEL.: +44 1942 850600 - FAX: +44 1942 812160

sales@samoaltd.uk - www.samoaltd.uk

SAMOA S.A.R.L.

FRANCE

P.A.E.I. DU GIESSEN

3, RUE DE BRISCHBACH

67750 SCHERWILLER, FRANCE

TEL.: +33 3 88 82 79 62 - FAX: +33 3 88 82 77 88

samoafrance@samoafrance.com - www.samoafrance.com

SAMOA-HALLBAUER GMBH

GERMANY AND AUSTRIA

INDUSTRIESTRASSE, 18

D-68519 VIERNHEIM, GERMANY

TEL.: +49 6204 7095-0 - FAX: +49 6204 7095-33

info@samoahallbauer.de - www.samoahallbauer.de

SAMSON CORPORATION

NORTH AMERICA

ONE SAMSON WAY

SWANNANOVA, NC 28778, USA

TEL.: +1 828 686 8511 - FAX: +1 828 686 8533

info@samsoncorporation.com - www.samsoncorporation.com

SAMOA CHINA SALES OFFICE

ROOM 702, RONG GUANG BUSINESS CENTER

572 KUN MING ROAD, SHANGHAI 200082, P.R. CHINA

TEL.: +86 21 5515 0064 - FAX: +86 21 5102 7883

china@samoaindustrial.com

©Copyright, SAMOA INDUSTRIAL, S.A.

SAMOA Industrial, S.A. is an ISO 9001, ISO 14001
and OHSAS 18001 certified company.

